

2006 BUICK LACROSSE



BUICK.COM / 800.4.A.BUICK

BUICK

BUICK





LaCROSSE.
PROUDLY CRAFTED BY
THE HIGHEST RANKED
PLANT IN NORTH AND
SOUTH AMERICA.

In the J.D. Power and Associates 2005 Initial Quality Study™ General Motors Oshawa 2 received the Gold Plant Quality Award in North/South America among plants producing cars for the U.S. market. It's the only plant that builds Buick LaCrosse. Study based on a total 62,251 U.S. consumer responses indicating owner reported problems during the first 90 days of ownership.

www.jdpower.com

THE QUALITY OF YOUR LIFE

Beautifully sculpted body panels that fit together with eye-pleasing precision. Quiet cabins that become a sanctuary from the outside world. Fabrics and materials that would feel perfectly at home in your home. Engines so smooth you may have to check the tachometer to be

ICKK

sure they're running. Suspensions that strike the elusive balance between precise control and a comfortable ride. Technology designed to help protect you and your family before, during and even after a collision.

Craftsmanship you sense everywhere you turn. Can cars have a level of quality that can actually improve the quality of your life? Welcome to LaCrosse.



THE QUALITY OF YOUR LIFE

Beautifully sculpted body panels that fit together with eye-pleasing precision. Quiet cabins that become a sanctuary from the outside world. Fabrics and materials that would feel perfectly at home in your home. Engines so smooth you may have to check the tachometer to be sure they're running. Suspensions that strike the elusive balance between precise control and a comfortable ride. Technology designed to help protect you and your family before, during and even after a collision. Craftsmanship you sense everywhere you turn. Can cars have a level of quality that can actually improve the quality of your life? Welcome to LaCrosse.

BUICK

W o r l d - c l a s s p o w e r . . . p e a c e f u l Q u i e t T u n i n g [™] . . . e x p e r t l y c r a f t e d i n t e r i o r



[PLATE 2] LaCrosse CXL in Black Onyx. Shown with available equipment.



【 PLATE 3 】 LaCrosse CXS leather-appointed interior in Ebony and Neutral. Shown with available equipment.

The world doesn't need another mid-size sedan. What it needs is a better one. Which is why there's the Buick LaCrosse. It's been created and crafted to feel unlike any other car in its class. Inside and out, craftsmanship prevails and ingenuity abounds. The fit and finish will compete with European luxury sedans. The available leather-appointed seats are detailed with French stitching.

The gauges have the look of Swiss chronographs. And the cabin has a library-like hush. The available 240-hp, 3.6-liter VVT V6 is one of the most advanced engines in the world. The suspension produces a ride that's smooth, yet makes the handling crisp, tight and controlled. Artfully designed. Elegantly appointed. Crafted with precision and finesse. LaCrosse wasn't created to merely equal. It was created to surpass.



L A C R O S S E : *building a better mid-size sedan*



【 PLATE 6 】 Craftsmanship in motion — LaCrosse CXL in Black Onyx. Shown with available equipment.

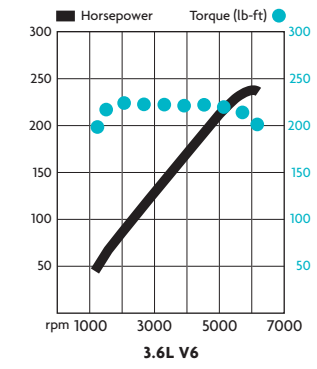

A. 3.6L VVT V6 ENGINE

General Motors recently developed, from a clean sheet of paper, a new family of sophisticated V6 engines for global application in premium and high-performance vehicles. The 3.6L version of this V6 family was the first to go into production. It is one of GM's most advanced engines, and it's standard on LaCrosse CXS. One of the world-class features of this all-aluminum engine is the use of fully variable valve timing (VVT) for both intake and exhaust, a first for any GM V6 engine. VVT reduces emissions and provides outstanding fuel economy.* Variable valve timing also gives this engine extreme flexibility. 90% of its peak torque is available across a broad operating range: 1,600–5,600 rpm. Its horsepower and torque are equally impressive: 240 hp, 225 lb-ft of torque.

*EPA estimated mpg 19 city, 27 hwy.

B. 3.8L 3800 SERIES III V6

With over 25 million sold, the 3800-engine family is the most proven powerplant in GM's inventory. The Series III version in the LaCrosse CX and CXL adds more refinement and response to the engine's outstanding record for performance and reliability. Electronic throttle control allows the engine to precisely tailor vehicle performance to driver demands. At low speeds it responds more slowly to aid in parking. At high speeds it acts quickly to heighten LaCrosse's performance character. Structural enhancements such as an aluminum oil pan, increased engine/transmission bracing and a stiffer die-cast aluminum intake manifold reduce vibration for smoother, quieter operation.

C. ABS/TRACTION CONTROL

The anti-lock braking system (ABS) helps you maintain stopping and steering control in emergency situations by automatically modulating the brakes when the wheel-speed sensors detect lockup. Those same sensors are used to detect wheel slippage for LaCrosse's available traction control system. When the drive wheel is found to be spinning much faster than the other wheels, a series of interventions is initiated to automatically reduce power and help control wheelspin. LaCrosse CXS has a traction control system that not only uses engine intervention but brake management — automatically applying the brakes at one or more of the four wheels, as required — for additional wheel slippage control. When traction is restored, power returns to normal levels.

Power

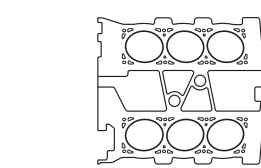

A.

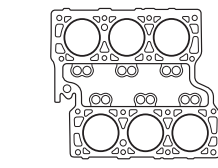

B.

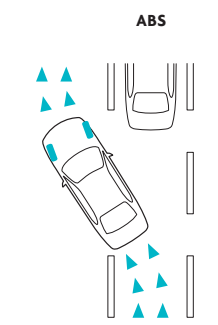

C.

A. SPORT-TUNED SUSPENSION

The Sport-Tuned suspension on LaCrosse CXS is impressively firm and controlled to match the model's high performance characteristics. The MacPherson strut coil-over-spring independent front and trailing arm rear design uses gas charged dampers with four-stage valving for precise control. 32-mm front-tubular and 19.4-mm rear-solid stabilizer bars help control body roll. The Sport-Tuned suspension was tuned to work in harmony with the 240-hp 3.6L VVT V6 that's standard on LaCrosse CXS.

B. STABILITRAK®—STABILITY CONTROL SYSTEM

Simply put, StabiliTrak has the ability to sense the direction in which you want your LaCrosse to be heading, and the power to help you stay on your intended course. This available chassis stability control system uses data from many sensors to work its magic. Yaw sensors, lateral accelerometers, steering wheel angle sensors, and wheel-speed sensors all send their data to the powertrain control module (PCM) and electronic control module (ECM) computers. These computers are constantly comparing the actual path the vehicle is taking with the path in which the driver is steering. If StabiliTrak senses that the vehicle is not responding to steering input, it modulates individual brakes or reduces power or both to help the driver maintain control and continue on the intended course. All this intervention can be so subtle you may never sense it's occurring. Keep in mind that while StabiliTrak is ingenious, it cannot repeal the laws of physics. Drive carefully.

C. MAGNASTEER™

LaCrosse CXS models feature Magnasteer I power rack-and-pinion steering. It has a quick 13.3:1 steering ratio and uses a computer-controlled electromagnet to adjust steering effort based on vehicle speed. In slow situations, like maneuvering in a parking lot, it increases assist to make steering easier. At highway speeds it reduces assist to give the driver better road feel. CXS models with StabiliTrak are equipped with Magnasteer II that analyzes both vehicle speed and lateral acceleration to determine steering effort for even more precise response.

h a d l i n g



A.

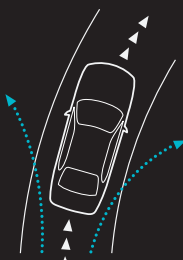

B.

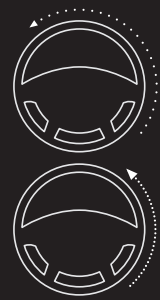

C.





【 PLATE 10 】 LaCrosse CXS leather-appointed interior in Ebony. Shown with available equipment.





QUIETTUNING

From its inception, LaCrosse was designed to achieve impressive levels of quietness. But our engineers wanted more. So they specified QuietTuning. It's a Buick-pioneered process that employs the following three strategies to transform LaCrosse's cabin into a sanctuary from the outside world.

A. REDUCE NOISE AT ITS SOURCE

Clearly, noise that is addressed at its source is noise that can't enter the vehicle and disturb its passengers. That is where our engineers began their quest for quiet. They first analyzed *wind noise* caused by the aerodynamic details of LaCrosse, and made design modifications to reduce that noise. They next examined *powertrain noise* coming from the available 3.6L V6 engine and found ingenious ways to quiet its sound without inhibiting its high-performance personality. They then specified a *Helmholtz resonator* that alters the acoustic pattern of the exhaust to make it both quieter and more pleasant sounding. Finally they employed an *acoustic engine cover* to dramatically reduce noise at its source.

B. BLOCK THE NOISE PATH

Much of the noise that can't be eliminated at its source can be denied entry into the passenger compartment. To that end, our engineers studied the noise entering the interior through the windows and the engine compartment and found a way to make a real difference. *Laminated front side-door glass and acoustic laminate windshield* are specified for every LaCrosse. Essentially two layers of glass of different thickness with a thin film of plastic laminated in between, it is this layered construction that helps block sound. An *acoustic front-of-dash laminated steel panel* forms a sound barrier between the engine and passenger compartment. The panel is made from special laminated steel. There are two layers of steel separated by a noise damping material that helps eliminate noise transmission and resonance. Our engineers also carefully analyzed the body of LaCrosse to identify other potential noise paths. They then sought out special materials to apply to those paths. As a result, *sideview mirror sound barriers, structural foam, body baffles, engine compartment side seals and 18 strategically positioned acoustic panel dampers* help block outside noise from ever reaching the cabin.

C. ABSORB NOISE IN THE CABIN

Despite all the efforts to deny its entry into the passenger compartment of LaCrosse, some noise manages to sneak in. Our engineers have an acoustic welcoming party waiting. *28 special acoustic absorbers* are strategically positioned under carpeting and behind interior trim to help absorb noise before it ever reaches the ears of LaCrosse's driver and passengers. The final result of the intensive QuietTuning process is a peaceful calm that pervades the cabin of LaCrosse. You'll be amazed by what you don't hear.

Quiet Tuning



A.

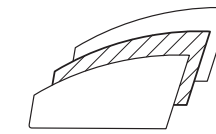

B.

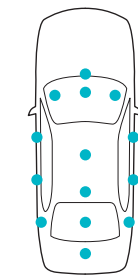

C.



【 PLATE 13 】 LaCrosse CXL in Cardinal Red Metallic. Shown with available equipment.



[PLATE 15] LaCrosse instrument panel. Flush surfaces, narrow gaps, chrome jewelry. Shown with available equipment.



A. XM® SATELLITE RADIO

Hovering in geosynchronous earth orbit, XM satellites beam down over 150 channels of clear, digital-quality sound into your LaCrosse. Over 800 terrestrial repeaters fill in the signal whenever the line of sight with a satellite is lost. XM delivers 67 channels of 100% commercial-free music, plus the best in news, sports, talk, comedy and XM Instant Traffic & Weather. And you can receive the signal in all 48 coast-to-coast states. That's the attraction of XM. And that's why it's available on LaCrosse. Plus, now you get three trial months of service with factory-installed XM without any contract or obligation.

XM is available only in the 48 contiguous United States. Service fees extra. Visit gm.xmradio.com for details.

B. 240-WATT PREMIUM AUDIO SYSTEM

Thanks to the peace created by QuietTuning, the interior of LaCrosse is the perfect environment for high-end audio — and a very impressive system is available. Start with a premium AM/FM receiver with a six-disc in-dash CD changer. Then add a nine-speaker sound system: one center channel speaker in the instrument panel, two high-mounted tweeters flanking the instrument panel, two large extended-range speakers in the front doors, plus two mid-range speakers and two woofers mounted co-axially on the rear shelf. They're all driven by a dedicated 240-watt amplifier. The result is exceptional depth, breadth, clarity and presence. A sound most living rooms would envy.

C. ONSTAR®

OnStar is a factory-installed safety and security system that helps keep you protected and connected on the road. Using global positioning satellites to locate your vehicle, a live, specially trained Advisor is there to help you with something as major as an air bag deployment or as minor as a lockout. With OnStar, you have access to OnStar Hands-Free Calling, a voice-activated calling feature, so you can stay better connected on the road. If your air bags deploy, OnStar receives a signal and will try to contact you to see if you need help. If you need emergency assistance, OnStar will contact a nearby emergency service provider with your request for help. If you have a flat, are out of gas, or need a tow, an Advisor is ready to help there too. OnStar can also work with police to locate your vehicle if it's stolen, in most cases send a signal to unlock your doors if you're locked out, or run GM® Goodwrench® remote diagnostics if your Check Engine light comes on. With OnStar, you'll have peace of mind knowing you've done all you can to protect your family and prepare for whatever comes down the road.

OnStar Hands-Free Calling (HFC) requires an HFC-enabled vehicle, existing OnStar service contract and prepaid calling minutes, and is not available in Alaska and some other markets. Calls may be made to the U.S. and Canada only. OnStar voice recognition system may not work with some voices.

OnStar services require vehicle electrical system (including battery), wireless service and GPS satellite signals to be available and operating for features to function properly. OnStar acts as a link to existing emergency service providers. Subscription Service Agreement required. Call 1-888-4ONSTAR (1-888-466-7827) or visit onstar.com for OnStar's Terms and Conditions, Privacy Policy and system limitations and details.

D. REMOTE VEHICLE START

With LaCrosse's available remote starting system, you'll never again have to endure a stiflingly hot car in the summer or a bone chillingly cold car in the winter. You can start your car from nearly 500 feet away by simply pushing a touch pad on the remote keyless entry. As the engine starts running, the heating-ventilation-air conditioning system goes into an automatic mode for optimal pre-cooling or pre-heating. The system senses the outside temperature and heats or cools as necessary regardless of the heat/air conditioning settings on the instrument panel. So if you parked your LaCrosse in the afternoon with the air conditioning on and it's cold the next morning, the system will heat the interior. The front defroster and rear defogger are also turned on if the outside temperature is below 40°F. The system also has many built-in safeguards to help prevent theft and unauthorized or unexpected use.

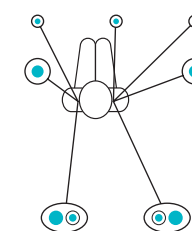

B.



D.

A. DUAL-ZONE AUTOMATIC CLIMATE CONTROL

LaCrosse's available dual-zone automatic climate control helps the driver and front passenger each live in their own little climatic world. It provides up to a 30°F difference between the two seating positions and automatically maintains the desired settings. Think of it. The driver could be basking in a 90° heat wave while the passenger is enjoying the nip of a 60° cold snap.

B. DRIVER INFORMATION CENTER

LaCrosse's available Driver Information Center (DIC) can provide an amazing array of important data as you drive. With its graphic displays positioned in the center of the instrument panel, the DIC can provide outside temperature and compass readings. Trip and odometer information. Elapsed time. Average speed. Fuel range. Average and instant fuel economy. Battery voltage. Oil life index. The DIC will also display warnings and alerts for up to 50 vehicle functions. From something as urgent as low brake fluid, to something as minor as when your key fob battery is running low. The Driver Information Center is a real comfort to have on board.

C. PERSONAL CHOICE SETTINGS

Choosing the available Driver Information Center gives two drivers the chance to make personal choice programming decisions for their individual comfort. Just unlock the door with your remote keyless entry and LaCrosse will recall your preset choices for: Driver identification. Radio settings. Favorite stations. Climate control settings. Automatic door locking and delayed unlocking features. Perimeter lighting. Even rear parking assist settings if your LaCrosse is so equipped. So every time you drive, your LaCrosse will feel as if it were built just for you.

comfort

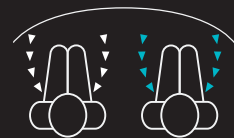

A.

TRACTION CONTROL ACTIVE

DRIVER'S DOOR AJAR

CHANGE OIL SOON

LEFT REAR TURN LAMP OUT

B.



C.



[PLATES 16, 17 & 18] The available flip-and-fold system easily converts from a three-passenger front seat to a two-passenger front seat with a versatile center console that can be configured in five different ways.



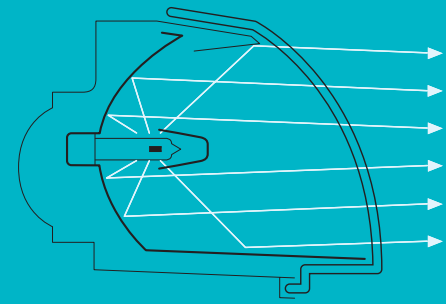

A. HIGH-INTENSITY HALOGEN HEADLAMPS

Seeing clearly down a dark road at night is a clear safety enhancement. LaCrosse is up to the task. Its headlamps use a four-bulb burn configuration, with the two high-beam lamps and the two high-intensity halogen low-beam lamps coming on together whenever the high beams are requested. The result is great nighttime visibility immediately ahead of your LaCrosse, and bright, uniform illumination further down the road.

B. DUAL-STAGE FRONT/HEAD-CURTAIN SIDE AIR BAGS

Occupant safety received high priority in the design of LaCrosse—with the goal of providing excellent protection in the event of a collision. LaCrosse's multiple air bag systems are designed to supplement the basic protection of safety belt usage. Both standard front air bags have a dual-stage design that deploys at one of two rates, depending on the severity of the collision. The frontal air bag system also has sensors to detect the weight and position of the front passenger. This helps provide more protection for out-of-position and smaller occupants. The standard head-curtain side air bags are mounted in the roof. When inflated, they drop all the way down to the belt line from the front to the rear of the passenger compartment, providing head protection for all outboard passengers in the event of a side impact.

C. ULTRASONIC REAR PARKING ASSIST

Nuclear submarine technology surfaces in your driveway. When you shift into reverse gear, sonar waves are sent out from four ultrasonic transmitter/receivers built into the rear bumper. If a parked vehicle, or stationary object at least ten inches high, is detected in your intended path, the sonar waves will bounce off the obstacle and back to the sensors in the bumper. The sensors will activate both an audio warning signal and warning lights if you are nearing an obstacle while backing up at low speed. The closer you get to the object, the more intrusive the alarms and lights become.

s a f e t y

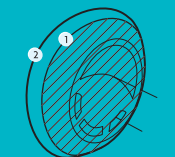

B.

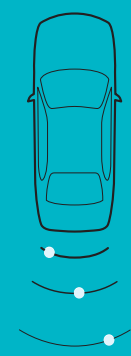

C.

[PLATE 20] LaCrosse rear tail lamp. Elegantly shaped, exceptionally well-crafted.

Quietly, Buick has taken its place among the world leaders in quality on some important measures. We've been recognized by industry experts. Our higher standards have been noted throughout the automotive press. Some of our key assembly plants have won prominent awards.

But we know that the difference between a car you like and a car you love isn't only about quality design and construction. It's also about a quality driving experience.

That's why, beginning with our 2006 models, every Buick we craft will come with these premium amenities:

- QuietTuning — a Buick-pioneered process that's designed to help reduce noise at its source, block the noise path and absorb noise. All to transform the cabin into a sanctuary from the outside world.
- OnStar* — a safety and security system that helps keep you protected and connected on the road. From a minor inconvenience to a major collision, a live, trained Advisor is there to help.
- A new 4 year/50,000 mile vehicle warranty** — premium coverage that is solid evidence of how confident we are in the quality of the design, engineering, assembly and craftsmanship of our vehicles.

For enhanced control on the road, every Buick model will offer either StabiliTrak — Stability Control System, or all-wheel drive. Some models will offer both.

And that's only the beginning. Our commitment to quality will continue to permeate every aspect of the creation of our vehicles. Every year. Every discipline. Every Buick.

That's our commitment to you.

*Visit onstar.com or call 1-888-4ONSTAR (1-888-466-7827) for system limitations and details.

**Whichever comes first. Limited warranty. See dealer for details.

The special rewards of driving a Buick



[PLATE 22] LaCrosse CXS paired headlamp pods — lighting the way to Buick's future. Shown with available Chrome Appearance Package.

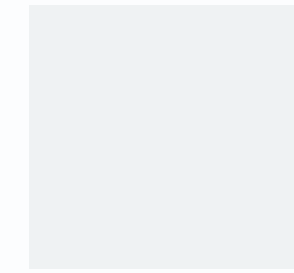

White Opal (40)
Interior: Neutral⁽¹⁾
Gray
Ebony⁽²⁾
Ebony and Neutral⁽³⁾



Platinum Metallic (67)
Interior: Gray
Ebony⁽²⁾
Ebony and Neutral⁽³⁾



Slatestone Metallic (46)
Interior: Gray
Ebony⁽²⁾
Ebony and Neutral⁽³⁾

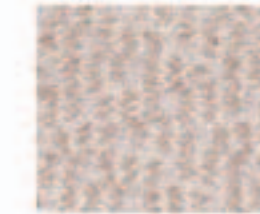

Neutral Cloth



Antique Bronze Metallic (53)
Interior: Neutral⁽¹⁾
Ebony and Neutral⁽³⁾



Glacier Blue Metallic (68)
Interior: Neutral⁽¹⁾
Gray
Ebony⁽²⁾
Ebony and Neutral⁽³⁾



Deep Sapphire Metallic (22)
Interior: Neutral⁽¹⁾
Gray
Ebony⁽²⁾
Ebony and Neutral⁽³⁾

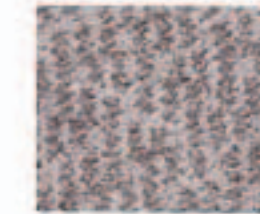

Gray Cloth



Cardinal Red Metallic (63)
Interior: Neutral⁽¹⁾
Gray
Ebony⁽²⁾
Ebony and Neutral⁽³⁾



Black Onyx (41)
Interior: Neutral⁽¹⁾
Gray
Ebony⁽²⁾
Ebony and Neutral⁽³⁾



Neutral Leather Trim



Gray Leather Trim



Ebony Leather Trim

⁽¹⁾Not available on CXS. ⁽²⁾Not available on CX. ⁽³⁾Not available on CX and CXL.



16" Deluxe Wheelcover



16" Aluminum Wheel



16" Chrome-Tech Aluminum Wheel



17" Aluminum Wheel



17" Chrome-Plated Aluminum Wheel

INTERIOR FEATURES	CX	CXL	CXS
S Standard A Available — Not available			
Air bags			
— driver and right-front passenger, frontal dual-stage inflation with right-front passenger sensing	S	S	S
— front and rear passengers head-curtain side-impact	S	S	S
Air conditioning			
— manual single-zone climate control with rear-seat outlet	S	—	—
— automatic dual-zone climate control, with rear-seat outlet	A	S	S
Air filtration system	S	S	S
Audio systems			
— ETR AM/FM stereo with seek/scan, digital clock, Theftlock,® CD, speed-compensated volume, auto tone control and six speakers	S	S	S
— ETR AM/FM stereo with seek/scan, digital clock, Theftlock, in-dash six-disc CD, speed-compensated volume, auto tone control and Concert Sound III speaker system	A	A	A
— ETR AM/FM stereo with seek/scan, digital clock, Theftlock, CD/MP3 player, speed-compensated volume, auto tone control and Concert Sound III speaker system	—	A	A
— XM® Satellite Radio (activation and service fees extra; not available in Alaska or Hawaii)	A	A	A
— Concert Sound III nine-speaker, 240-watt premium audio system (requires six-disc CD or CD/MP3 player)	A	A	A
— remote steering-wheel controls	A	A	A
Carpet savers — front and rear, stain-resistant	S	S	S
Child seat anchors — rear-seat upper and lower LATCH system for compatible child safety seats	S	S	S
Cruise control — electronic	S	S	S
Driver Information Center — includes compass and basic trip computer; reminder lights for low oil and fuel levels, oil life monitor, door and trunk ajar, personal programming functions; two separate trip odometers; calculations for instant fuel economy, miles to empty and gallons of fuel used	A	S	S
Inside rearview mirror — electrochromic-auto dimming	—	A	A
Instrumentation — backlit analog cluster with tachometer, trip odometer, temperature and fuel gauges	S	S	S
Lights — delayed entry and exit courtesy lighting with theater dimming, front reading, trunk, instrument panel courtesy and glove box	S	S	S
— reading, rear seat	—	A	A
OnStar® — includes one-year Safe & Sound Plan*	S	S	S
Power door locks — programmable with memory and lockout protection features, includes rear child security locks	S	S	S

INTERIOR FEATURES (continued)	CX	CXL	CXS
Power windows — include driver express-down and rear passenger lockout feature	S	S	S
QuietTuning™	S	S	S
Rear window defogger — electric	S	S	S
Remote keyless entry — with individually programmable transmitters, includes instant alarm, activation verification and perimeter lighting	S	S	S
Remote vehicle starter system — keyfob activated	A	A	A
Safety belts — front and rear lap/shoulder belts	S	S	S
Seats			
— cloth	S	—	—
— leather-appointed	—	S	S
— front bucket with six-way power driver	S	S	S
— heated driver and right front passenger	—	A	A
— rear split folding with folding armrest and dual cup holders	A	S	S
— power driver lumbar	A	S	S
— power six-way driver	S	S	S
— power six-way front passenger	—	A	A
— six passenger, includes front center flip-and-fold configurable storage console, seat cushion, lap safety belt, dual cup holders, power outlet and column-mounted transmission shifter	A	A	—
Steering wheel			
— four-spoke, includes cruise control	S	—	—
— leather-appointed with cruise control	A	S	S
— leather-appointed with cruise, audio and temperature controls	A	A	A
Sunshades — front, supplemental, extendable	S	S	S
Theft-deterrent systems			
— content theft alarm	A	S	S
— PASS-Key® III passive theft deterrent	S	S	S
TILT-WHEEL™			
— adjustable steering column	S	—	—
— adjustable steering column with telescopic feature	A	S	S
Transmission shifter			
— leather-wrapped	S	S	—
— Burl wood tone	—	—	S
Trunk lock release — power activation	S	S	S
Trunk release handle — mounted inside the trunk	S	S	S
Universal Home Remote — programmable three-button function remote for garage door and more	—	A	A
Visor vanity mirrors			
— driver and front passenger, extendable	S	—	—
— lighted, driver and front passenger, extendable	A	S	S

EXTERIOR FEATURES	CX	CXL	CXS
Chrome Appearance Package — includes front and rear chrome fascia inserts and body side molding inserts	—	A	A
Chrome door handles	S	S	S
Fog lamps — halogen, projector type	—	—	S
Headlamps — include daytime running lamps with Twilight Sentinel®	S	S	S

EXTERIOR FEATURES (continued)	CX	CXL	CXS
Mirrors			
— dual power remote	S	S	S
— dual heated power remote	—	A	A
Molding — body-side, body-color	S	S	S
Spoiler — trunk-mounted, dealer-installed	A	A	A
Sunroof — power sliding and tilting with sunshade	A	A	A
Tires			
— P225/60R16 steel-belted, all-season	S	S	—
— P225/55R17 steel-belted, all-season touring	—	—	S
Ultrasonic rear parking assist	—	A	A
Wheels			
— 16" steel wheel with deluxe wheelcover	S	—	—
— 16" aluminum	A	S	—
— 16" Chrome-Tech aluminum	—	A	—
— 17" aluminum	—	—	S
— 17" chrome-plated aluminum	—	—	A
Windshield wipers			
— two-speed with variable delay	S	S	S

MECHANICAL FEATURES	CX	CXL	CXS
Battery — with rundown protection	S	S	S
Brakes — four-wheel anti-lock disc	S	S	S
Engine			
— 3.8L 3800 V6	S	S	—
— 3.6L VVT DOHC V6	—	—	S
Engine block heater	A	A	A
Exhaust			
— single muffler, stainless steel	S	S	—
— dual muffler, stainless steel	—	—	S
StabiliTrak® — Stability Control System — automatic	—	—	A
Steering			
— power-assisted rack-and-pinion	S	S	—
— Magnasteer™ I, quick-ratio, magnetic variable-effort, speed-sensitive power-assisted rack-and-pinion	—	—	S
— Magnasteer II, quick-ratio, magnetic variable-effort, lateral acceleration and vehicle speed-sensitive power-assisted rack-and-pinion (with StabiliTrak—Stability Control System only)	—	—	A
Suspension			
— four-wheel independent, Premium Ride	S	S	—
— Sport-Tuned, includes high-damping struts, upgraded front and rear stabilizer bars	—	—	S
Traction control			
— enhanced, powertrain modulated	A	A	—
— full-range, powertrain and brake modulated	—	—	S
Transmission — four-speed electronically controlled automatic with overdrive and transmission shift interlock	S	S	S

*OnStar services require vehicle electrical system (including battery), wireless service and GPS satellite signals to be available and operating for features to function properly. OnStar acts as a link to existing emergency service providers. Subscription Service Agreement required. The U.S. Federal Communications Commission (FCC) ruled that wireless carriers will no longer be required to support the analog wireless network beginning in 2008. As of January 1, 2008, OnStar plans to offer service only through equipment that operates on the digital network which may require the purchase of a system upgrade for eligible vehicles. Call 1-888-4ONSTAR (1-888-466-7827) or visit onstar.com for OnStar's Terms and Conditions, Privacy Policy and system limitations and details.

ENGINE	CX	CXL	CXS
Type	3.8L 3800 Series III V6		
Horsepower	200 @ 5200 rpm		
Torque	230 @ 4000 rpm		
Axle ratio	2.86		
EPA estimated mpg, city/hwy	20/29		
Type	3.6L VVT DOHC V6		
Horsepower	240 @ 6000 rpm		
Torque	225 @ 2000 rpm		
Axle ratio	3.69		
EPA estimated mpg, city/hwy	19/27		
CAPACITIES			
Trunk (cu. ft.)**	16.0		
Fuel tank (approx. gal.)	17		
Base curb weight (lbs.)			
— CX	3,495		
— CXL	3,502		
— CXS	3,568		

EXTERIOR DIMENSIONS (inches)	CX	CXL	CXS
Length	198.1		
Width	73.0		
Height	57.4		
Wheelbase	110.5		
Front tread	61.7		
Rear tread	61.5		

INTERIOR DIMENSIONS (inches)	CX	CXL	CXS
— Legroom	42.3/37.6		
— Headroom	39.4/37.2		
— Shoulder room	57.2/57.0		
— Hip room	55.3/54.6		

**Cargo and load capacity limited by weight and distribution.

IMPORTANT WORDS ABOUT THIS BROCHURE.

We have tried to make this brochure comprehensive and factual. We reserve the right, however, to make changes at any time, without notice, in prices, colors, materials, equipment, specifications, models, and availability. Specifications, dimensions, measurements, ratings and other numbers in this brochure and other printed materials provided at the dealership or affixed to vehicles are approximates based upon design and engineering drawings and prototypes and laboratory tests. Your vehicle may differ due to variations in manufacture and equipment. Since some information may have been updated since the time of printing, please check with your Buick dealer for complete details. Buick reserves the right to lengthen or shorten the model year for any product for any reason, or to start and end model years at different times.

New Vehicle Limited Warranty. This warranty is for GM vehicles registered in the USA. See your Buick dealer for terms and conditions. **Covered for 4 years/50,000 miles (whichever comes first):** The complete vehicle • Tires • Towing to your nearest Buick dealership • Cosmetic corrosion resulting from defects • Repairs made to correct any vehicle defect • No charge for most warranty repairs **Covered for 6 years/100,000 miles (whichever comes first):** Rust-through corrosion

Corrosion Protection. Buick vehicles are designed and built to resist corrosion. All body and sheet metal components are warranted against rust-through corrosion for six years or 100,000 miles, whichever comes first. Application of additional rust-inhibiting materials is not required under the corrosion coverage and none is recommended. See your Buick dealer for terms of this limited warranty.

An Important Note About Alterations and Warranties. Installations or alterations to the original equipment vehicle (or chassis) as distributed by General Motors are not covered by the General Motors New Vehicle Limited Warranty. The special body company, assembler, equipment installer or upfitter is solely responsible for warranties on the body or equipment and any alterations (or any effect of the alterations) to any of the parts, components, systems or assemblies installed by GM. General Motors is not responsible for the safety or quality of design features, materials or workmanship of any alterations by such suppliers.

Updated Service Information. Buick dealers receive useful service bulletins about Buick products. You may purchase them from Helm Incorporated by calling 1-800-551-4123 or by visiting www.helminc.com.

Assembly. Buick vehicles and their components are assembled or produced by different operating units of General Motors, its subsidiaries or suppliers to GM worldwide. We sometimes find it necessary to produce Buick vehicles with different or differently sourced components than originally scheduled. Since some options may be unavailable when your vehicle is assembled, we suggest that you verify that your vehicle includes the equipment you ordered or, if there are changes, that they are acceptable to you.

Engines. Buick products are equipped with engines produced by GM Powertrain or other suppliers to GM worldwide. The engines in Buick products may also be used in other GM makes and models.

A Note About Child Safety. Always use safety belts and proper child restraints, even in vehicles equipped with air bags. Even with the Passenger Sensing System, children are safer when properly secured in a rear seat. Never place a rear-facing infant restraint in the front seat of any vehicle equipped with an active air bag. See your vehicle Owner's Manual and child safety seat instructions for more information.

ENHANCE YOUR OWNERSHIP EXPERIENCE. The Owner Center at My GMLink is a free online service that helps you make the most of your vehicle ownership.

- Sign up for e-mail reminders about service visits
 - Keep an online history of services performed
 - Read your Owner's Manual, warranty, and more, online
 - Receive the recall notices that apply only to your vehicle
 - Watch do-it-yourself videos and much more
- Register today at MYGMLink.com!

GM, the GM Logo, Buick, the Buick Logo, OnStar, the OnStar Emblem, QuietTuning and the slogans, emblems, vehicle model names, vehicle body designs and other marks appearing in this brochure are the trademarks and/or service marks of General Motors Corporation, its subsidiaries, affiliates or licensors. The XM name and related logos are registered trademarks of XM Satellite Radio, Inc.

©2005 General Motors Corporation. All rights reserved.

Printed on recyclable paper from a renewable source.

Ident. No. 06-LAC-001

Printed in U.S.A. 300m