



PONTIAC

THE NEW POWER OF PONTIAC

2004





BY IMAGINING, DESIGNING, AND ENGINEERING CARS THAT USE POWER,
PERFORMANCE, AND STYLING AS PROPELLANTS TO STIR YOUR SENSES.
THAT'S FUEL FOR THE SOUL.

pontiac.com

TOTAL PERFORMANCE

At Pontiac, we work toward a single-minded goal of transferring the mere act of driving into pure exhilaration. This type of design and engineering acumen is used to channel the power of world-class V8s and supercharged V6s to technologically advanced transmissions and suspension systems. It has allowed us to create systems that react to most every driving challenge and road condition. Above all, it enables the driver to be in complete control of the driving experience. This is the new power of Pontiac.



For more information, go to pontiac.com.

Some photos shown in this catalog may contain optional equipment.



FROM LEFT TO RIGHT > Bonneville GXP in Graystone Metallic > Grand Prix GTP with available Competition Group Package in Galaxy Silver Metallic > GTO in Phantom Black Metallic

> WICKED



> GTO shown in Phantom Black Metallic

GTO The modern reincarnation of a performance legend.



Legendary Power

- > The most powerful GTO ever built
- > All-aluminum 5.7L Gen III LS1 V8 engine
- > 350 hp @ 5200 rpm
- > 365 lb-ft of torque @ 4000 rpm
- > 0-60 mph in the mid-five-second range
- > Available Tremec close-ratio 6-speed manual
- > Performance-tuned Hydra-Matic 4L60-E automatic
- > Dana 3.46:1 performance rear axle ratio
- > True dual exhaust – twin converters, resonators, and mufflers with asymmetrical chrome outlets for one awesome exhaust note

Impressive Handling

- > Rear-wheel drive
- > Fully independent rear suspension
- > Limited-slip differential
- > Front and rear direct-acting stabilizer bars
- > Bosch three-channel traction control system
- > 55/45 weight distribution, balanced for excellent performance
- > 245/45 ZR17 W-rated BFGoodrich g-Force T/A performance tires

Performance Interior

- > 2+2 all-leather bucket seating with sports-styled bolsters
- > Machine-drilled accelerator, brake, and clutch pedals
- > Blaupunkt 200-watt 10-speaker audio with 6-CD changer
- > Color-coordinated, sport gauge package
- > Satin nickel interior appointments
- > Driver Information Center



Gen III LS1 V8 engine with 350 horsepower

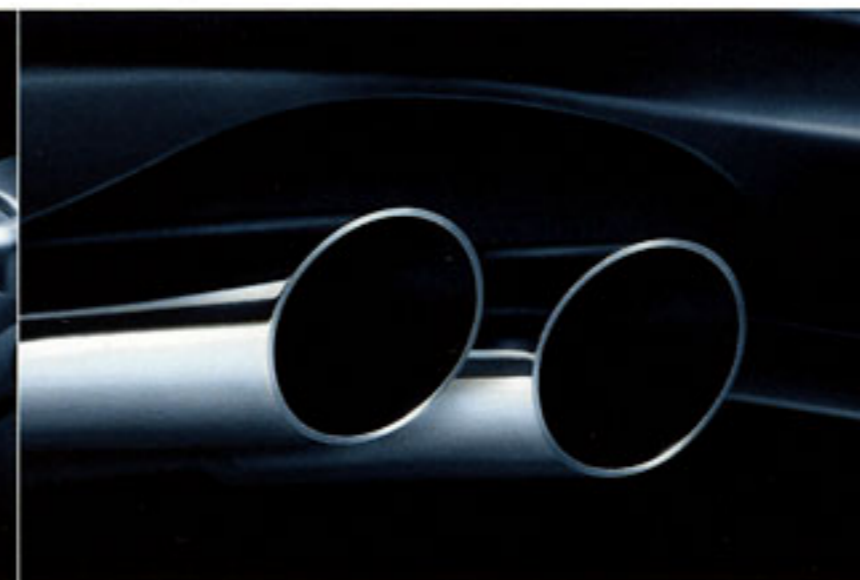

Dual exhaust with asymmetrical chrome outlets



Color-coordinated sport gauges

To learn even more about GTO—and to hear its legendary exhaust note—go to pontiac.com/gto.

GTO will be available late 2003.

BONNEVILLE GXP Power, performance, and luxury – no compromise.

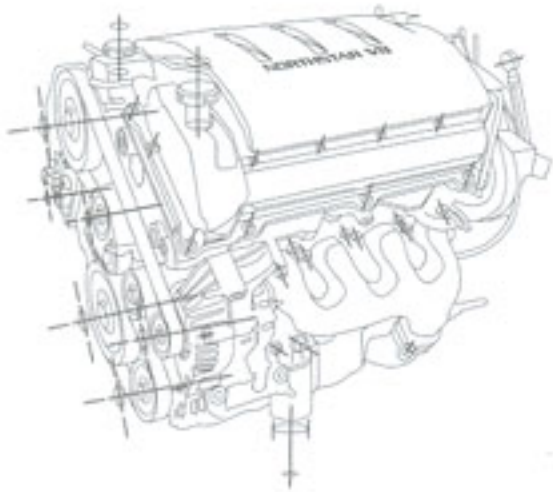

World-Class Power

- > Smooth and quiet 275-hp 4.6L Northstar V8 engine delivers 300 lb-ft of torque
- > Large valves (four per cylinder) feed more air to each cylinder, providing immediate access to power at any speed
- > 0-60 in 6.5 seconds, top speed is 135 mph
- > The GXP's engine produces more power than a BMW 330i, BMW 530i, and Lexus ES 330
- > An advanced Hydra-Matic 4T80-E automatic transmission with performance algorithm shifting that adapts to the driver's style
- > Performance-tuned exhaust system with dual/dual outlets

Performance-Tuned Handling System

- > Le Mans-inspired four-wheel independent suspension
- > Large front and rear stabilizer bars for flatter cornering and reduced body roll
- > Tower brace and a refined cradle-mount package add to structural rigidity
- > P235/50WR18 tires on 18" flangeless alloy wheels
- > StabiliTrak stability enhancement system helps you control all of this power
- > High-capacity 12.7" vented front brake rotors and 11.7" solid rear brake rotors with red-highlighted calipers
- > 3.71:1 axle ratio is the most aggressive ratio found on any sport sedan in its class

Premium-Appointed Interior

- > Spacious five-passenger luxury interior
- > Carbon fiber appearance detail and satin nickel accents abound
- > Leather-appointed seating with UltraLux suede inserts
- > Exclusive EyeCue Head-Up Display* communicates vehicle speed, turn signal, low fuel and more by projecting it right onto the windshield—available
- > Power front driver and passenger seats adjust in 12 different ways and feature power lumbar and memory presets for two drivers



275-hp 4.6L Northstar V8 engine



Front/rear brakes with red-highlighted calipers and W-rated tires



GXP interior door shown with carbon fiber detail

To learn even more about Bonneville SE, SLE, and GXP models, go to pontiac.com/bonneville.

Bonneville GXP will be available late 2003. Unless otherwise noted, all competitive comparisons are based on the latest information available at time of printing. *Excludes other GM vehicles.

> COMMANDING



> Bonneville GXP shown in Graystone Metallic

> REBORN



> Grand Prix GTP with available Competition Group Package shown in Graystone Metallic

GRAND PRIX GTP WITH COMPETITION GROUP PACKAGE (Comp G) The new definition of total performance.

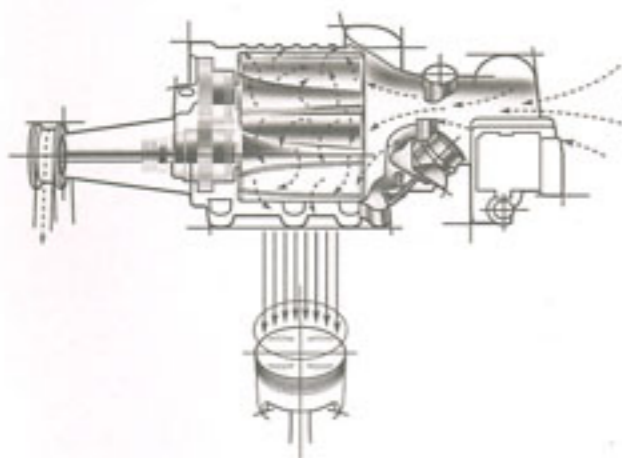

Best Performing

- > Grand Prix GTP is the most powerful car in its class*
- > Grand Prix GTP features the award-winning 3800 Series III V6
- > Supercharged with 260 hp and 280 lb-ft of torque
- > More powerful than BMW 330i
- > Electronic Throttle Control: smooth delivery of power at low speeds and highly responsive at highway speeds

Best Handling

- > Comp G handles better than the Audi A6 3.0
- > Comp G Package includes:
 - Specific suspension tuning
 - 17" V-rated performance tires
 - Segment-exclusive TAPshift
 - StabiliTrak Sport (stability control system)
 - Magnasteer II speed-sensitive steering
 - 3.29:1 rear axle ratio
 - Red-highlighted calipers
- > All-new four-wheel disc braking system with electronic brake force distribution, providing a shorter stopping distance than Nissan Maxima SE and Mazda 6s**

Unmatched Functionality

- > Split-folding, fold-flat rear seatbacks more than double trunk space when folded
- > Near 90-degree opening doors mean easier entry and exit
- > Enlarged trunk pass-through creates more room between the passenger compartment and the trunk
- > Wider, low liftover deck lid. No problem loading or unloading heavy, bulky items
- > Fold-flat front-passenger seat converts to a tabletop work area and allows a nine-foot object to be stowed†



3800 Series III Supercharged V6 engine



TAPshift – steering wheel-mounted shift paddles



Fold-flat rear seats and front-passenger seat

To learn even more about Grand Prix GT and GTP models, go to pontiac.com/grandprix.

*Based on comparably equipped front-wheel-drive sedans in the *Automotive News* 2003 mid-range standard segment. Level of equipment varies. **Based on Grand Prix GTP with available Competition Group Package vs. comparably equipped front-wheel-drive sedans available at time of testing in the *Automotive News* 2003 mid-range standard segment. Level of equipment varies. Testing performed by Pro Formance and sanctioned by SCCA. †Always secure loose items.

GRAND AM GT Recharge your passion for driving.

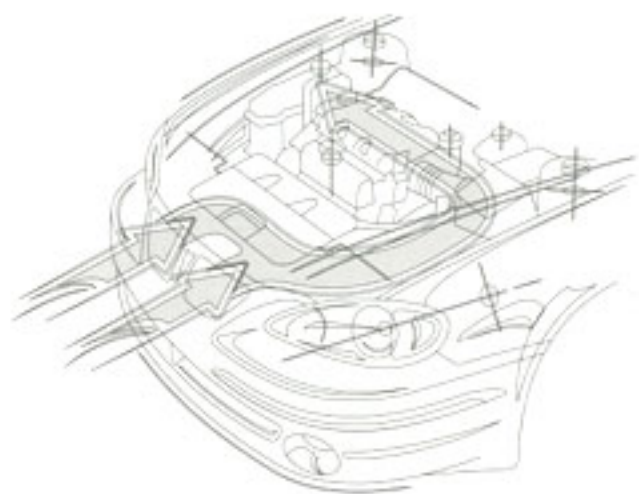

Ram Air Performance

- > 3400 V6 Ram Air engine has 175 hp and 205 lb-ft of torque
- > Most horsepower and torque for a coupe in its segment*
- > Off-the-line acceleration resulting in 0-60 in under 8 seconds
- > Largest V6 engine in its segment**

Aerodynamic Styling

- > Aerodynamic sport styling
- > Wedge-shaped design makes this car look fast even when standing still
- > Chrome Tech 16" cast aluminum wheels for true sports car styling—available
- > SC/T Appearance Package with composite Performance Ram Air hood design and distinctive rear aero wing spoiler—available

Driver-Oriented Cockpit

- > Interior design helps driver to be totally engaged in driving control
- > Ergonomically designed layout of instruments and controls within easy reach of driver
- > Steering wheel buttons with audio and cruise control access allows driver to keep hands on the wheel—available
- > Quick-read analog gauges, backlit in red, provide visibility for night driving
- > Monsoon sound system with CD, eight speakers, seven-band graphic equalizer, and available MP3 player



3400 V6 Ram Air engine



SC/T Appearance Package—available



Backlit red analog gauges

To learn even more about Grand Am GT and SE models, go to pontiac.com/grandam.

*Based on J.D. Power and Associates 2003 entry midsize car segmentation. **Excludes other GM vehicles.

> STIMULATING



> Grand Am GT shown in Galaxy Silver Metallic

> BOLD



> Sunfire shown in Silver Metallic

SUNFIRE Fast moves and bold styling neatly wrapped in a sleek sport coupe.

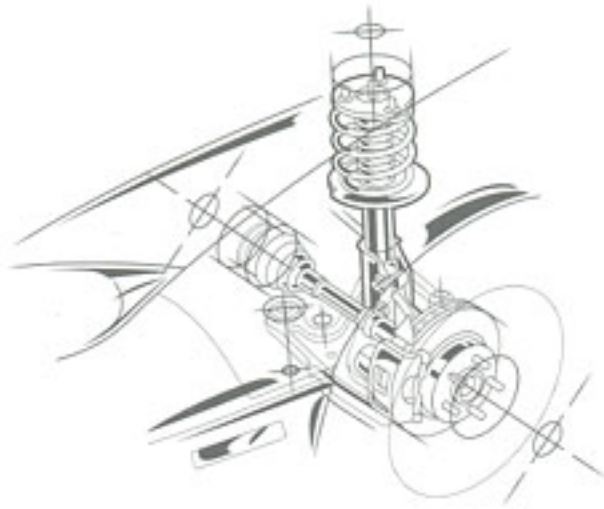

Proven Performance

- > The 2.2 liter DOHC Ecotec engine in Sunfire makes it one of the most powerful cars in its class
- > Getrag 5-speed manual transmission helps give Sunfire great performance and smooth shifts
- > Four-wheel ABS and Enhanced Traction System—available

Sleek Styling

- > Ground-hugging, aerodynamic design looks fast even while standing still
- > Sporty standard features such as rear deck lid spoiler, sport breakaway mirrors, and integrated fog lamps
- > 16" cast aluminum wheels with performance tires—available

Sensible Value

- > Long list of standard features, including AC, PASSLock theft-deterrent system, and rear defogger
- > Variety of option packages available to provide even more fun for the price
- > Impressive fuel economy: EPA estimated 26 mpg city/33 mpg highway (manual transmission)



2.2L Ecotec engine



Sunfire interior shown in Graphite



Available Monsoon audio system with MP3-capable CD player and available XM Satellite Radio*

To learn even more about Sunfire, go to pontiac.com/sunfire.

*Service fees required. Available only in the 48 contiguous states. Visit www.gm.xmradio.com for details.

VIBE GT Unprecedented flexibility for uncommon adventures.

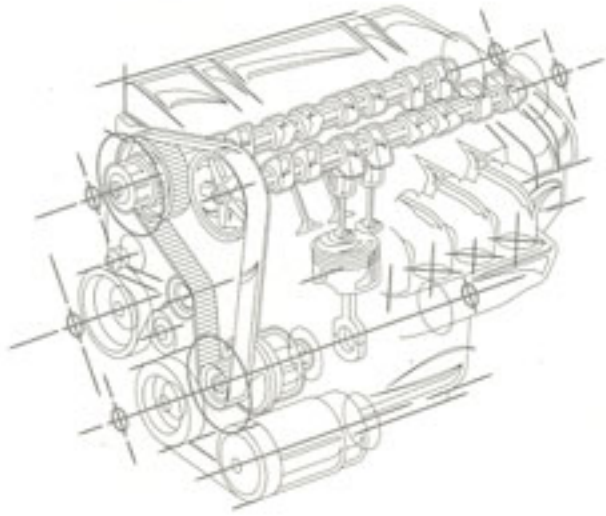

Dynamic Performance

- > The 173-hp 1.8L DOHC engine is one of the most powerful in its class (requires premium fuel)
- > A performance-tuned four-cylinder engine and a 6-speed manual transmission usually found only on high-end performance cars
- > 0-60 in the low eight-second range thanks to variable-valve timing intelligence and a variable-valve lift system
- > Specially calibrated sport-tuned suspension with front and rear stabilizer bars

Boundless Versatility

- > Five-passenger seating or extra cargo room, thanks to fold-flat front-passenger and split-folding rear seats
- > 54 cubic feet of cargo room* when rear seats are folded
- > Built-in rear adjustable cargo system with four tie-down anchors and scratch-resistant load floor
- > Nine concealed storage compartments
- > Standard fully functional load-bearing roof rack

Entertaining Technology

- > DVD-based navigation system with remote 6-disc CD changer and programmable equalizer with Radio Data System (RDS)—available
- > XM Satellite Radio—available**
- > Household-style plug (AC)



6-speed transmission on GT models



Built-in rear adjustable cargo system accommodates loads of various sizes



DVD-based navigation system—available

To learn even more about Vibe, Vibe GT, and Vibe AWD models, go to pontiac.com/vibe.

*Cargo and load capacity limited by weight and distribution. **Service fees required. Visit www.gm.xmradio.com for details.

> LIMITLESS



> Vibe GT shown in Satellite Metallic

> Montana AWD shown in Liquid Silver Metallic

> **ADVENTUROUS**



MONTANA EXTENDED-LENGTH AWD The minivan for everyone who has ever said they'd never own one.

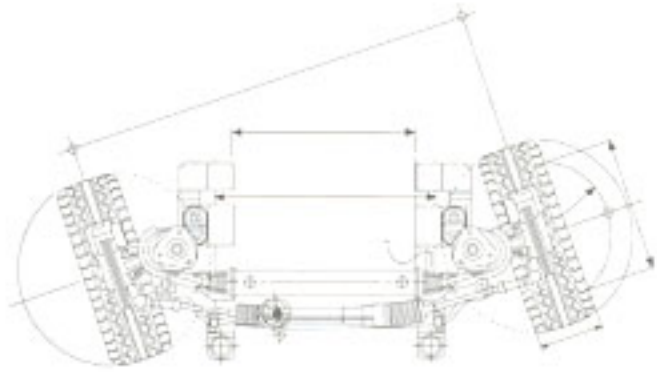

Rugged Performance & Handling

- > Chrome Sport Package—16" chrome-finished aluminum wheels, rear spoiler, independent front suspension, FE4 performance-tuned rear suspension with automatic level control, and hose inflator kit—available
- > Advanced, all-weather VERSATRAK AWD optimizes road grip and control in challenging situations
- > VERSATRAK transfers power to each rear wheel either individually or simultaneously as needed
- > Smooth ride and unsurpassed AWD minivan fuel economy*
- > 185-hp outpowers standard engines on many minivans and SUVs

Unconfined Functionality

- > Over 140 cubic feet of cargo room**—larger than the full-size Ford Expedition
- > Seating for eight—more seating capacity than almost every midsize SUV—available
- > Dual sliding doors create an opening over a yard wide
- > The first minivan to offer a remote power-sliding door—now available on passenger and driver side
- > Theater-style seating for improved forward visibility
- > Folding modular buckets seats—easy to remove (40 lbs.) or fold flat for increased cargo capacity

Total Entertainment

- > XM Satellite Radio†—available
- > MP3 capable player—available
- > In-dash 6-disc CD player—available
- > Factory-installed MontanaVision DVD system covered by the three-year/36,000-mile New-Vehicle Limited Warranty—available (See dealer for details)

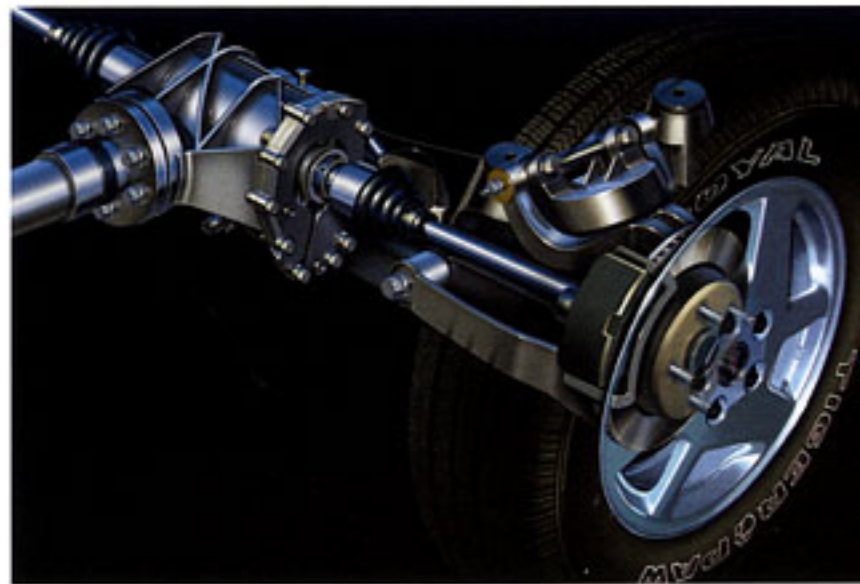

VERSATRAK AWD



Over 140 cubic feet of cargo space**



MontanaVision 7" flip-down LCD screen—available

To learn even more about all of the Montana models, go to pontiac.com/montana.

*EPA estimated 18 mpg city/24 mpg highway. **Cargo and load capacity limited by weight and distribution. †Service fees required. Available only in the 48 contiguous states. Visit www.gm.xmradio.com for details.

AZTEK AWD Unlike anything else on or off the road.

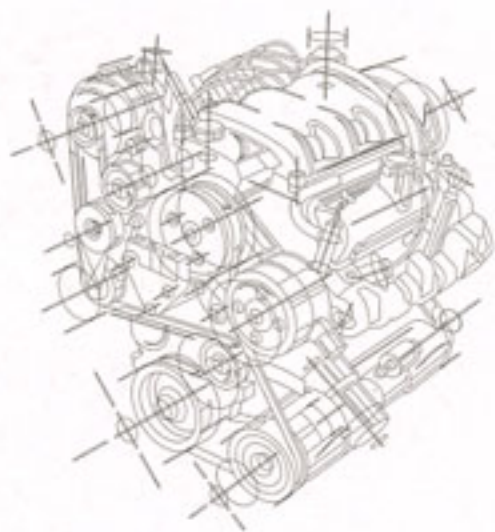

Unleashed Performance

- > 3.4 liter 3400 V6 engine with 185 hp and 210 lb-ft of torque has more standard power than midsize SUVs like Nissan Xterra XE, Mitsubishi Montero Sport LS, and Toyota Highlander
- > VERSATRAC AWD responds automatically, directing torque to the rear wheel with the best grip
- > Trailer Package enables Aztek to tow snowmobiles, jet skis, etc. (up to 3,500 lbs.)* –available
- > Rally Package – 17" chrome-finished aluminum wheels with Goodyear tires, chrome-finished exhaust tip, and lowered front suspension –available

Unconstrained Capacity

- > Segment-exclusive removable second-row seats**
- > 16 unique cargo configurations
- > 93 cubic feet of maximum cargo volume† (more maximum cargo room than Ford Explorer and Dodge Durango)
- > More overall passenger room than Nissan Pathfinder, Toyota 4Runner, and Nissan Xterra and offers more second-row leg room than Dodge Durango, Ford Explorer, and Jeep Grand Cherokee

Interior Ingenuity

- > Truly unique and segment-exclusive features such as console cooler, Tent Package, and rear cargo tray –available
- > Factory-installed Rear-Seat Entertainment System including flip-down 7" color monitor, DVD/CD player with remote control, two sets of wireless headphones, and AV inputs –available
- > Rear cargo area audio controls –available



Rally Edition Package –available



Interior shown in Dark Taupe cloth



Camping Package –available

To learn even more about all of the Aztek models, go to pontiac.com/aztek.

*Maximum trailer-weight ratings are calculated assuming a base vehicle, except for any options necessary to achieve the ratings, plus the driver. The weight of other optional equipment, passengers, and cargo will reduce the maximum trailer weight your vehicle can tow. 10 to 15% of the trailer weight is the recommended trailer tongue load. See your Pontiac dealer for additional details. **Excludes other GM vehicles. †Cargo and load capacity limited by weight and distribution.

> RENEGADE



> Aztek AWD shown in Liquid Gray Metallic

> CONFIDENT



ONSTAR



Pontiac's commitment to performance driving means keeping you safe on the road. Pontiac offers the quality, technology, and safety of OnStar on many of its vehicles. With a variety of services that help keep you safe when you're on the road, the OnStar Safe & Sound Plan (available on select models) offers its subscribers added peace of mind. Just press the blue OnStar button and an OnStar Advisor will personally answer your call. A highly trained OnStar Advisor can contact roadside assistance if you get a flat tire, assist local authorities in locating your car if it's stolen, and help unlock your doors if you lock your keys in the car. OnStar Advisors will call to find out if you need help if your air bags deploy. And, if you do need help, they can pinpoint your location by satellite and contact a nearby emergency service provider, like the police or an ambulance. All of the following services and more are available to you when you subscribe to the one-year OnStar Safe & Sound Plan: >Automatic notification of air bag deployment >Emergency services >Roadside assistance >Stolen-vehicle tracking >Accident assistance >Remote door unlock >Remote diagnostics >Remote horn and lights

Air bag inflation can cause severe injury or death to anyone too close to the bag when it deploys. Be sure every occupant is properly restrained.



OnStar Advisors are automatically alerted if your air bags deploy and will call to see if you need help.



Contacting OnStar is easy, simply push the button located on the rearview mirror.

For important system limitations and details about OnStar, go to the next page and visit onstar.com.

IMPORTANT WORDS ABOUT THIS CATALOG

We have tried to make this catalog comprehensive and factual. We reserve the right, however, to make changes at any time, without notice, in prices, colors, materials, equipment, specifications, models, and availability. Since some information may have been updated since the time of printing (September 2003), please check with your Pontiac dealer for complete details. Pontiac reserves the right to lengthen or shorten the model year for any product for any reason, or to start and end model years at different times.

ENGINES

Pontiac products are equipped with engines produced by GM Powertrain or other suppliers to GM worldwide. The engines in Pontiac products may also be used in other GM makes and models.

ASSEMBLY

Pontiac vehicles and their components are assembled or produced by different operating units of General Motors, its subsidiaries, or suppliers to GM worldwide. We sometimes find it necessary to produce Pontiac vehicles with different or differently sourced components than originally scheduled. Since some options may be unavailable when your vehicle is assembled, we suggest that you verify that your vehicle includes the equipment you ordered or, if there are changes, that they are acceptable to you.

NEW-VEHICLE LIMITED WARRANTY

This warranty is for GM vehicles registered in the USA. See your Pontiac dealer for terms and conditions. Covered for three years/36,000 miles, whichever comes first: the complete vehicle, tires, towing to your nearest Pontiac dealership, cosmetic corrosion resulting from defects, repairs made to correct any vehicle defect, and no charge for most warranty repairs. Covered for six years/100,000 miles, whichever comes first: rust-through corrosion.

CORROSION PROTECTION

Pontiac vehicles are designed and built to resist corrosion. All body and sheet metal components are warranted against rust-through corrosion for six years or 100,000 miles, whichever comes first. Application of additional rust-inhibiting materials is not required under the corrosion coverage and none is recommended. See your Pontiac dealer for terms of this limited warranty.

AN IMPORTANT NOTE ABOUT ALTERATIONS AND WARRANTIES

Installations or alterations to the original equipment vehicle (or chassis) as distributed by General Motors are not covered by the General Motors New-Vehicle Limited Warranty. The special body company, assembler, equipment installer, or upfitter is solely responsible for warranties on the body or equipment and any alterations (or any effect of the alterations) to any of the parts, components, systems, or assemblies installed by GM. General Motors is not responsible for the safety or quality of design features, materials, or workmanship of any alterations by such suppliers.

UPDATED SERVICE INFORMATION

Pontiac dealers receive useful service bulletins about Pontiac products. You may purchase them from Helm Incorporated by calling 1-800-551-4123 or by visiting www.helminc.com.

UPROMISE

GM is proud to be the only car company that can help you save for college with Upromise—for you, your children, your grandchildren, or any child you care about. GM has teamed up with Upromise, a free service that can help you turn your everyday spending, with hundreds of America's leading companies, into college savings. Once you join Upromise for free, every time you use your credit card, make a long-distance phone call, shop online, buy gas, dine out—even buy an eligible new GM car or truck—you can get a portion of your purchase back as college savings. It's free to join, and takes just minutes. Learn more and join for free today at upromise.com/gmcatalog.

A NOTE ABOUT CHILD SAFETY

Always use safety belts and proper child restraints, even in vehicles equipped with air bags. Children are safer when properly secured in a rear seat. Never place a rear-facing infant restraint in the front seat of any vehicle equipped with an active air bag. See your vehicle Owner's Manual and child safety seat instructions for more information. Pontiac supports the National SAFE KIDS Campaign,® a grassroots program dedicated to reducing unintentional childhood injuries.

ONSTAR

OnStar services require vehicle electrical system and analog wireless services to be available and operating for features to function properly. OnStar uses existing emergency service providers as well as analog wireless and satellite technologies and is subject to their limitations. The U.S. Federal Communications Commission (FCC) ruled that wireless carriers will no longer be required to support the analog wireless network after February 16, 2008. After that time, if the carriers for OnStar elect to only provide digital service, OnStar service will only be available through dual-mode hardware, which may require the purchase of a system upgrade. Call 1-888-4ONSTAR (1-888-466-7827), see your OnStar Owner's Guide, or visit www.onstar.com for system limitations and details.

ENHANCE YOUR OWNERSHIP EXPERIENCE

The Owner Center at My GMLink is a free online service that helps you make the most of your vehicle ownership. Register today at www.mygmlink.com.

©2003 GM Corp. All rights reserved. Pontiac, Pontiac logo, Bonneville, StabiliTrak, GTP, Grand Prix, PASSLock, Grand Am, Sunfire, Ecotec, VERSATRAK, Montana, and Aztek are registered trademarks and Fuel for the Soul, Competition Group Package, WideTrack, GTO, and Vibe are trademarks of General Motors Corporation. Monsoon is a registered trademark of Delphi Corporation. OnStar, the OnStar button, and OnStar logo are registered trademarks of OnStar Corporation.

PONTIAC PERFORMANCE MODEL LINEUP

GTO

2+2 bucket seating
Rear-wheel drive
All-aluminum 5.7L V8 engine
350 hp @ 5200 rpm, 365 lb-ft torque
Close-ratio 6-speed manual or
4-speed automatic transmission

BONNEVILLE

Models: SE, SLE, GXP

> **BONNEVILLE SE**

3.8L 3800 Series II V6 engine
205 hp, 230 lb-ft torque
4-speed automatic transmission

> **BONNEVILLE SLE**

3.8L 3800 Series II V6 engine
205 hp, 230 lb-ft torque
4-speed automatic transmission

> **BONNEVILLE GXP**

4.6L Northstar V8 engine
275 hp, 300 lb-ft torque
High-performance, specially
tuned suspension

GRAND PRIX

Models: GT1, GT2, GTP

> **GRAND PRIX GT1 & GT2**

3.8L 3800 Series III V6 engine
200 hp, 230 lb-ft torque
4-speed automatic transmission

> **GRAND PRIX GTP**

3.8L 3800 Series III
Supercharged V6 engine
260 hp, 280 lb-ft torque
4-speed automatic transmission

> **AVAILABLE COMPETITION GROUP PACKAGE**

GRAND AM

Models: SE, SE1, SE2 Sedans;
GT Coupe & Sedan

> **GRAND AM SE & SE1 Sedan**

2.2L Ecotec engine
140 hp, 150 lb-ft torque
5-speed manual transmission

> **GRAND AM SE2 Sedan**

3400 SFI V6 engine
170 hp, 195 lb-ft torque
4-speed automatic transmission

> **GRAND AM GT Coupe & Sedan**

3400 V6 Ram Air engine
175 hp, 205 lb-ft torque

SUNFIRE

Trim Levels: 1SV, 1SA, 1SB, 1SC

5-passenger seating
2.2L Ecotec engine
140 hp, 150 lb-ft torque

> **SUNFIRE 1SV**

5-speed manual transmission (standard)

> **SUNFIRE 1SA**

5-speed manual transmission (standard)

> **SUNFIRE 1SB**

4-speed automatic transmission (standard)

> **SUNFIRE 1SC**

4-speed automatic transmission (standard)
Anti-lock brakes
16" Chrome Tech wheels

VIBE

Models: Vibe, Vibe GT, Vibe AWD

> **VIBE**

1.8L DOHC VVT-i engine
130 hp, 125 lb-ft torque
5-speed manual transmission (standard)
4-speed automatic transmission (available)
Available supercharger

> **VIBE GT**

1.8L DOHC VVT-i engine
173 hp, 127 lb-ft torque
(requires premium fuel)
6-speed manual transmission

> **VIBE AWD** – All-wheel drive

1.8L DOHC VVT-i engine
123 hp, 118 lb-ft torque
4-speed automatic transmission
with overdrive

MONTANA

Models: Regular Length,
Extended Length,
Extended-Length AWD

3.4L 3400 V6 engine
185 hp, 210 lb-ft torque
4-speed automatic transmission

AZTEK

Models: Aztek, Aztek VERSATRAC AWD

3.4L 3400 V6 engine
185 hp, 210 lb-ft torque
4-speed automatic transmission

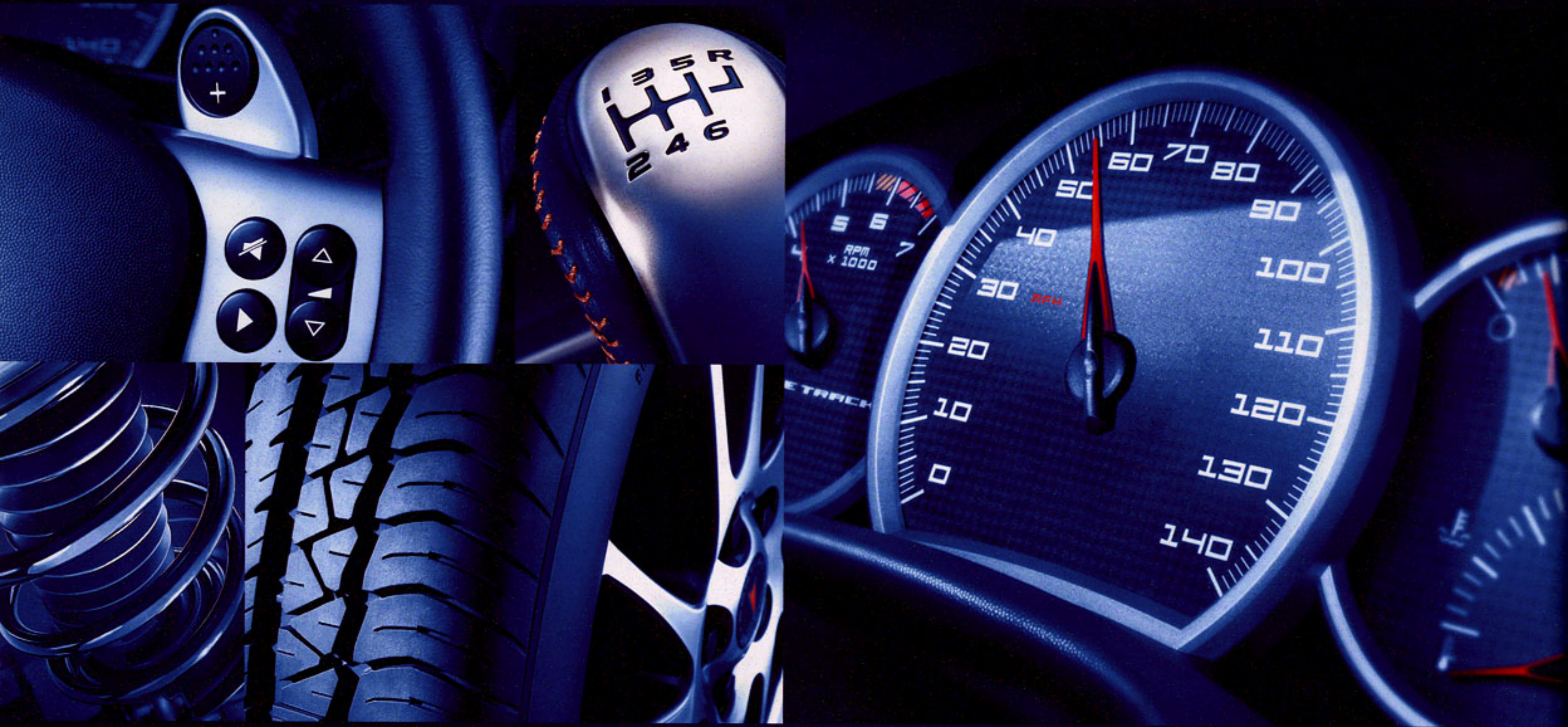

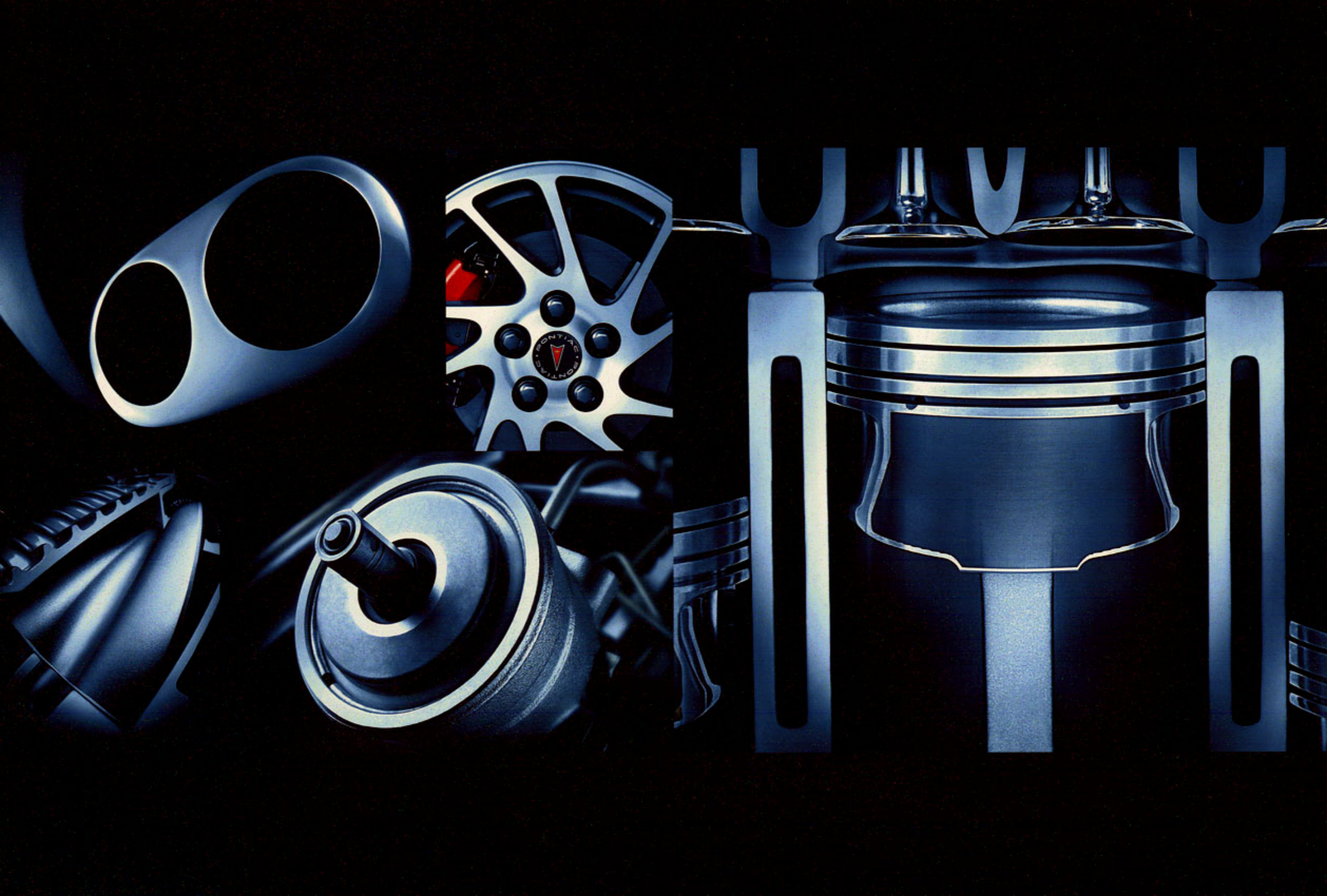



PONTIAC

Fuel for the Soul

PONTIAC.COM