

PONTIAC FIREBIRD 1991



FIREBIRD COUPE



Pontiac's performance leader makes its most impressive visual statement outfitted in the optional Sport Appearance Package. This package includes special front and rear fascias, lower-body aero skirts, a sleek rear valance panel and a rear deck spoiler. For information on other available options, please see your dealer.

The exterior look of the Sport Appearance Package comes in monotone Black, Medium Grey Metallic, Bright Red, Brilliant Red, Medium Green Metallic, or Arctic White colours. An exterior clearcoat deepens the lustre of each finish.



For 1991, the legendary Firebird Coupe includes redesigned front and rear fascias, rear deck spoiler, Hi-Tech Turbo cast aluminum wheels and Touring T/A radial tires.

Coupes above shown with Sport Appearance Package.

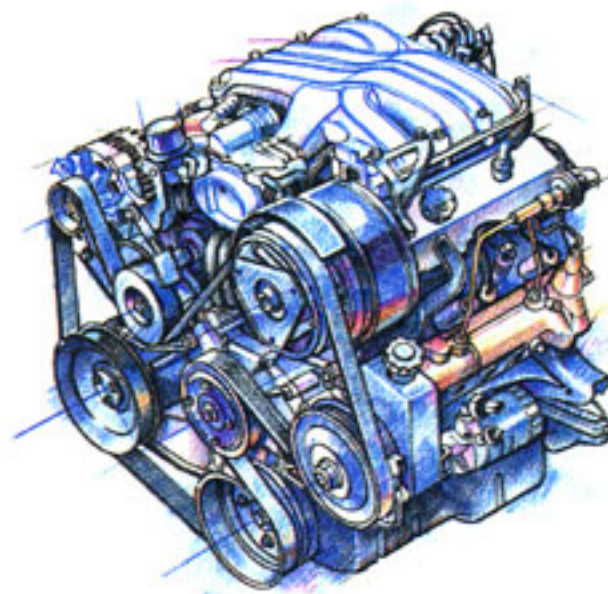

Firebird Coupe's 3.1L V6, with revised cylinder heads, a stroked crankshaft and multi-port fuel injection, harnesses 140 hp.



With Hi-Tech Turbo cast aluminum rims and steel-belted blackwall radials shouldering out from the wheel wells, this Firebird looks as good standing still as it feels in action.

Under the hood, you'll find a sporty 3.1L V6 with multi-port fuel injection and 140 hp. It breathes easily through a low-restriction aluminum intake manifold, maximizes power and optimizes timing advance with electronic spark control. The optional engine is the 5.0L V8 with electronic fuel injection (EFI). It packs 170 hp, 255 lbs.-ft. of torque and a throaty exhaust that talks Pontiac performance. Match either of these powerplants with the standard 5-speed manual transmission or the optional 4-speed automatic.

The full list of standard equipment on the Coupe is too lengthy to list here, but among them are power brakes, concealed headlamps, tinted glass and wet-arm windshield wipers.



PASS-Key® is the key to peace of mind for Firebird owners. The dark insert in the key shank is a specific resistor. Without its "code", special systems will prevent the car from starting.



We hope you'll never need the Supplemental Inflatable Restraint System (air bag) in every Firebird steering wheel. Along with a safety belt, it helps protect the driver in the event of a frontal collision.

FORMULA & TRANS AM



Meet Pontiac's authorities on performance for 1991. The Trans Am and Formula have the driving characteristics to back up their impressive appearance.

Combining form and function, the front fascia's undersurface is formed with special intake ducts that channel cool air to the front brakes. A redesigned rear deck spoiler and rear valance give you enhanced aerodynamics.

Those of you who appreciate a little well-applied muscle will be glad to know that V8s are still in the programme for these legendary Coupes. Formula comes with a 5.0L EFI V8 and optional 5.0L or 5.7L V8s with tuned-port fuel injection (TPI). Trans Am starts off with the 5.0L V8 with TPI then tempts you with the big 5.7L engine. For

transmissions, a 4-speed automatic is available with any powerplant, while a 5-speed manual is standard with everything except the 5.7L V8.

Both Trans Am and Formula offer special suspensions. For Trans Am, Level II suspension is standard, delivering Firm Ride and Handling. Level III Performance suspension means even bigger front and rear stabilizer bars, special springs, bushings, Z-rated Goodyear Eagle "Gatorback" tires and 16" charcoal Diamond-Spoke cast aluminum wheels. Formula has Level III suspension standard, plus 16" Deep-Dish Hi-Tech Turbo wheels.



Stay tuned for 235 hp. The specially formed runners of this High Output 5.7L V8 are designed to harmonize with the engine's firing order and valve timing to create performance-enhancing tuned intake pulses.

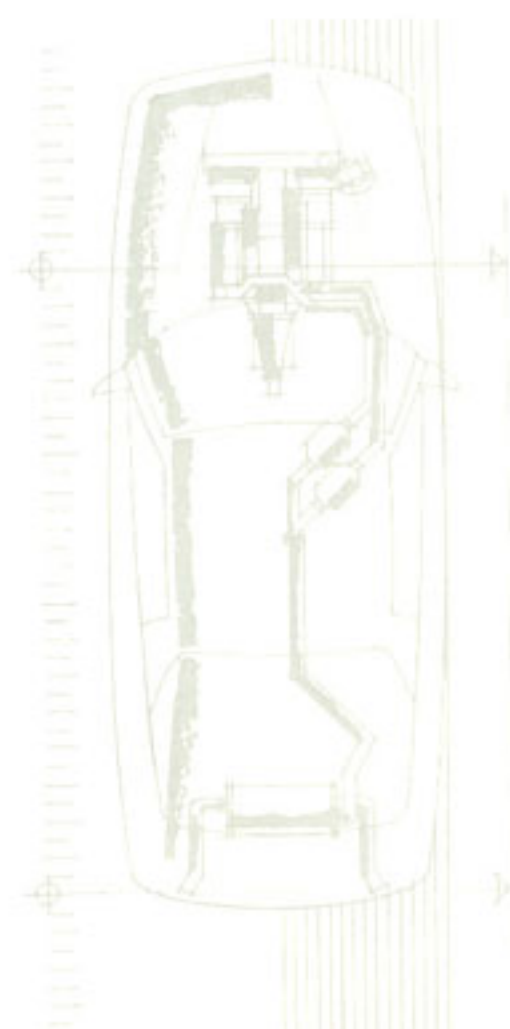

A low restriction, twin catalytic converter exhaust system gives Formula and GTA with the 5.0L with TPI V8 and 5-speed a 12.5% power boost over a conventional exhaust system. It's also standard with any 5.7L V8.

TRANS AM GTA



We saved the best for last: Trans Am GTA. With its High Output 5.7L V8, this is the Firebird that delivers 235 hp in tuned-port fuel-injected performance. Its excitement builders include tuned intake runners, a high-performance roller lifter cam, a special octane sensor for optimum timing advance, a low-restriction twin catalytic converter exhaust system with 57.2mm (2¼") headpipes and a 3.23:1 limited slip rear axle.

The handling package consists of 36mm front and 24mm rear stabilizer bars, gas-filled deflected disc shocks and struts, quick-ratio power steering, power 4-wheel disc brakes and Goodyear Eagle "Gatorback" tires on 16X8" Gold Diamond-Spoke cast aluminum wheels.

Inside GTA you'll find full analog instrumentation with performance-rated speedometer, cruise control, a bank of rocker switches and power articulating front bucket seats. There is also a Delco AM stereo/FM stereo sound system with cassette and graphic equalizer plus a leather-wrapped steering wheel and shift knob. Move it and you're in control of a 4-speed automatic transmission or optional 5-speed manual, should you choose the 5.0L V8 engine.



The new rear wing for the GTA is shaped like an inverted airfoil for enhanced effectiveness. The chrome tailpipes are fair warning of the potential rumbling in its 235 hp exhaust.

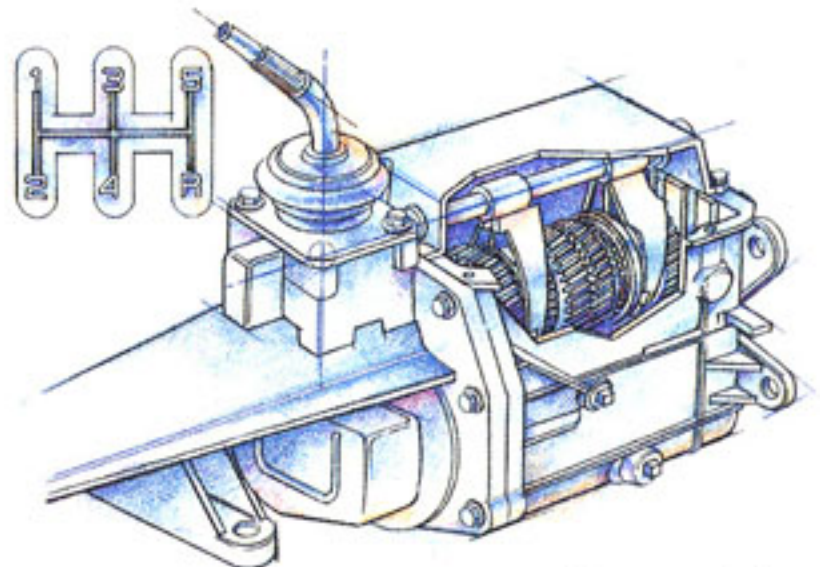

The gear ratios in Firebird Coupe's 5-speed manual transmission are designed with Pontiac performance in mind. From first gear up, it's 4.03:1, 2.37:1, 1.50:1, 1.00:1 and 0.76:1.

TRANS AM GTA



Models Available

Firebird Coupe, Firebird Coupe with Sport Appearance Package, Firebird with Formula Option, Trans Am, Trans Am with GTA Option.

Colours Available

Silver Blue Metallic, Arctic White, Black, Brilliant Red Metallic, Bright Red, Medium Grey Metallic, Bright Blue Metallic, Medium Green Metallic.

Engines

3.1L V6: 140 hp, 180 lbs.-ft. torque; multi-port fuel injection; low-restriction aluminum intake manifold; electronic spark control.

5.0L V8: 170 hp, 255 lbs.-ft. torque; electronic fuel injection; fast-burn combustion chambers; roller valve lifters.

High Output 5.0L V8 with Tuned-Port Fuel Injection: 200 hp, 295 lbs.-ft. torque in Formula and Trans Am with 4-speed automatic; 225 hp and 300 lbs.-ft. torque in Formula and GTA with 5-speed manual. Aluminum tuned runner intake manifold; roller-lifter hydraulic cam.

High Output 5.7L V8 with Tuned-Port Fuel Injection: 235 hp and 340 lbs.-ft. torque. Aluminum tuned runner intake manifold; high-performance, roller-lifter hydraulic cam; fast-burn combustion chambers.

Engine/Transmission Teams

5-speed manual	5.0L V8s & 3.1L V6
4-speed automatic	All engines

Brakes, f/r: Power vented 266.7mm (10.5") front disc/241.3mm (9.5") rear drum on Coupes, Formula with 5.0L with EFI. Power four-wheel vented disc 266.7mm (10.5") front/297.2mm (11.7") rear with 5.7L V8s or with 5.0L V8 with TPI and 5-speed on Formula or GTA.

Steering type, ratio: Power, recirculating ball; Level I, 14:1; Level II, III, 12.7:1, quick-ratio with Sport Effort Valving.

Turns, lock-to-lock: Level I, 2.72; Level II, 2.26; Level III, 2.26.

Turning circle: Level I 11.7m (38.5 ft.) dia; Level II, III 12.3m (40.3 ft.) dia.

Tires: Level I, P215/65R15 Touring T/A radials; Level II, P215/60R16 Touring; Level III, P245/50ZR16 Goodyear Eagle ZR50 "Gatorback."

Key Numbers

Wheelbase: 2565mm (101.0"). **Overall length:** 4956mm (195.1") Coupe, Formula; 4958mm (195.2") Coupe with Sport Appearance Package, Trans Am and GTA. **Width:** 1849mm (72.8"). **Overall height:** 1262mm (49.7"). **Curb weight:** 1403kg to 1579kg (3117 lbs. to 3508 lbs.). **Tank:** 58.7L (12.9 gal.). **Trunk:** 292L/877L (10.3/31.0 cu. ft.) with rear seat up/down.

Road Performance Figures

(Firebird Trans Am GTA with 5.7L V8 engine, 4-speed automatic transmission and 3.23:1 axle ratio)

Lateral acceleration, g's	0.90
Weight/horsepower ratio	15:1

A WORD ABOUT THIS CATALOGUE

The vehicles described incorporate components produced by General Motors of Canada Limited and related companies and suppliers. During manufacturing, different components than initially scheduled may be used. All illustrations and specifications are based on the latest product information at time of publication approval. The right is reserved to make changes at any time, without notice, in prices, colours, materials, equipment, specifications and models, and to discontinue models. Some of the equipment shown or described is available at extra cost or can only be ordered in conjunction with the other optional equipment. Some options may not be available when your vehicle is built. Check with your dealer for complete information.

A WORD ABOUT ENGINES

Pontiacs are equipped with engines produced at facilities operated by GM car groups, subsidiaries or affiliated companies worldwide.

A WORD ABOUT CORROSION PROTECTION

Your 1991 Pontiac Firebird was designed and built to resist corrosion. It comes with a standard 6-year/160,000 kilometres corrosion perforation limited warranty. Application of additional rust-inhibiting materials is not necessary or required under the 6-year/160,000 kilometre corrosion coverage. Ask your dealer for details.



If you order Option 1LE on your 1991 Trans Am you get the same suspension and brakes developed for Firebirds used across Canada in the Player's Ltd./GM Motorsport series.

PONTIAC FEEL IT!



GM TOTAL™
3-YEAR/80,000 KILOMETRE
WARRANTY

GM's 3 year/80,000 km new vehicle warranty covers the entire vehicle (including tires). A \$100 deductible per repair visit applies after the first 12 months or 20,000 km.