



Jeep<sup>®</sup> 1989





SOME OF THE EQUIPMENT SHOWN OR DESCRIBED THROUGHOUT THIS CATALOG IS AVAILABLE AT EXTRA COST.

**ABOUT THIS CATALOG.** SINCE THE TIME OF PRINTING, SOME OF THE INFORMATION YOU'LL FIND HERE MAY HAVE BEEN UPDATED. SEE YOUR DEALER FOR DETAILS.

JEEP IS A REGISTERED TRADEMARK OF JEEP EAGLE CORPORATION.

1989 Jeep vehicles (clockwise from top left):  
Grand Wagoneer, Wagoneer Limited,  
Wrangler, Cherokee, and Comanche.



## This has always been the place where the trail ends and the Jeep legend begins.

From the beginning, there have been those special people who have chosen to pursue a path less traveled than the rest. Through a world untamed and unyielding. At times, unforgiving. In search of what can only be found at the furthest outposts of civilization. Where nature begins to reveal her true wonder and magnificence.

We used to call such people *pioneers*.

Today, as it has for nearly half a century, Jeep understands this personal urge to go where the roads do not. For despite others' claims of toughness, no other automotive name evokes a truer, clearer image of places wild and uncharted. For no



other family of vehicles was created exclusively to serve and, if you will, to honor that spirit of adventure.

And the freedom to pursue it.

Because there's more than one way to pursue a legend, Jeep has developed a wide range of vehicles suited to a diversity of driving needs. Everything from a small sport utility (Jeep Wrangler), to family sport utilities (Jeep Cherokee and Wagoneer Limited), to shortbed and longbed pickup trucks (Jeep Comanche), to a full-size luxury sport utility (Grand Wagoneer).

Yet each comes with the most important standard feature of all: the Jeep name.

And because Jeep recognizes that, regretfully, most of us must spend the greater portion of our time in more so-called civilized surroundings, it has introduced for our bumper-to-bumper world what to some may seem unexpected innovations: roominess, comfort, and convenience.

In fact, what you may find most remarkable about Jeep is a technology that can withstand the rigors of off-roading, yet can accommodate perfectly the requirements of travel over paved surfaces. A balance engineered through sophisticated technological means.

Let's talk about accommodation, for example. Body-contoured seating. Ergonomically defined instruments. Advanced climate control. Premium sound. In short, a very modern

automotive environment.

Or look at passenger roominess. Jeep engineers positioned Cherokee's rear seat *ahead* of the rear wheel-houses, providing ample hiproom for three people, not just two as found



in most competitive sport utilities.

Plus, the best accommodation of all: choice. With a selection of models and options from which to choose on each Jeep vehicle.

It's not surprising then that technology that can find its way to the middle of nowhere and back out again should find itself at home wherever you live.

## Only in a Jeep





# It takes a lot of guts to make such a powerful statement.

Actions always speak louder than words. And Jeep's advanced design and engineering technology ultimately speaks for itself.

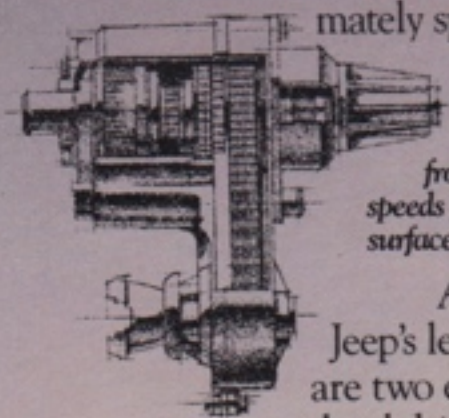

Selec-Trac has a differential that allows different front and rear wheel speeds for full-time all-surface operation.

At the heart of Jeep's legendary status are two exclusive four-wheel drive systems.

Jeep Selec-Trac® offers the only full-time shift-on-the-fly four-wheel drive system built in America. It lets you remain in four-wheel drive indefinitely, over any road surface, without causing excessive wear to drivetrain components. And Command-Trac®, Jeep's innovative part-time four-wheel drive system, also offers shift-on-the-fly capability.

- A. 4.0L Power-Tech I-6 Engine
- B. 4-Speed Automatic Trans.
- C. Selec-Trac Transfer Case
- D. Front Propeller Shaft
- E. Rear Propeller Shaft
- F. ABS Front Wheel-Speed Sensors
- G. ABS Power Brake Booster, Accumulator, and Modulator Assembly
- H. ABS Motor Pump
- J. ABS Electronic Control Module Unit
- K. ABS Rear Wheel-Speed Sensors

The driving force behind this legendary performance is a selection of Jeep powerplants. The 4.0 litre MPI 6-cylinder Power-Tech Six delivers 177 horsepower and up to 224 foot-pounds of torque, making it the most powerful engine in its class. The 2.5 litre TBI 4-cylinder, with 121 horsepower and up to 141 foot-pounds of torque, is the most powerful 4-cylinder engine in its class. And Grand Wagoneer's standard 5.9 litre V8. All with outstanding trailer-towing power. Plus, there's Wrangler's optional 4.2 litre 6-cylinder with the best low-speed torque rating in its class—up to 210 foot-pounds at only 2000 rpm.

Another Jeep powertrain advancement is the 4-speed automatic over-

drive transmission available on selected models. It includes a fourth gear overdrive, lockup torque converter, electronic shift control, and a driver-selected shift schedule that lets you go from fuel-efficient "Comfort" to quick-shifting "Power" at the push of a button.

A major development in Jeep technology is the new optional four-wheel anti-lock brake system—an industry exclusive. Available on some four-wheel drive models, this advanced system features independent wheel speed sensors, a

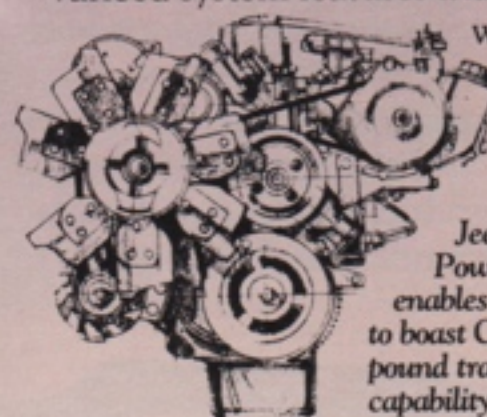

Jeep's 4.0 litre Power-Tech Six enables Jeep vehicles to boast Class III 5000-pound trailer-towing capability.

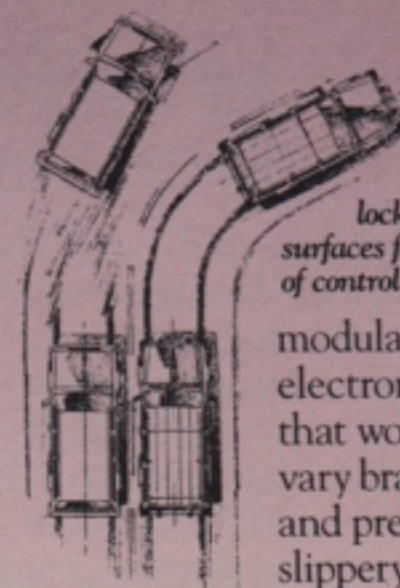

New optional exclusive four-wheel anti-lock brake system helps prevent lockup over slippery road surfaces for an added measure of control.

modulator unit, and an electronic control unit that work together to vary brake fluid pressure and prevent lockup on slippery road surfaces

for an added measure of control.

Jeep technology also extends to vehicle strength, durability, and riding comfort with Jeep's tough UniFrame integral body-frame construction and exclusive road-responsive Quadra-Link® front suspension.

Call it Jeep fortitude. Or just plain guts. However you look at it, Jeep technology is the stuff of which legends are made.

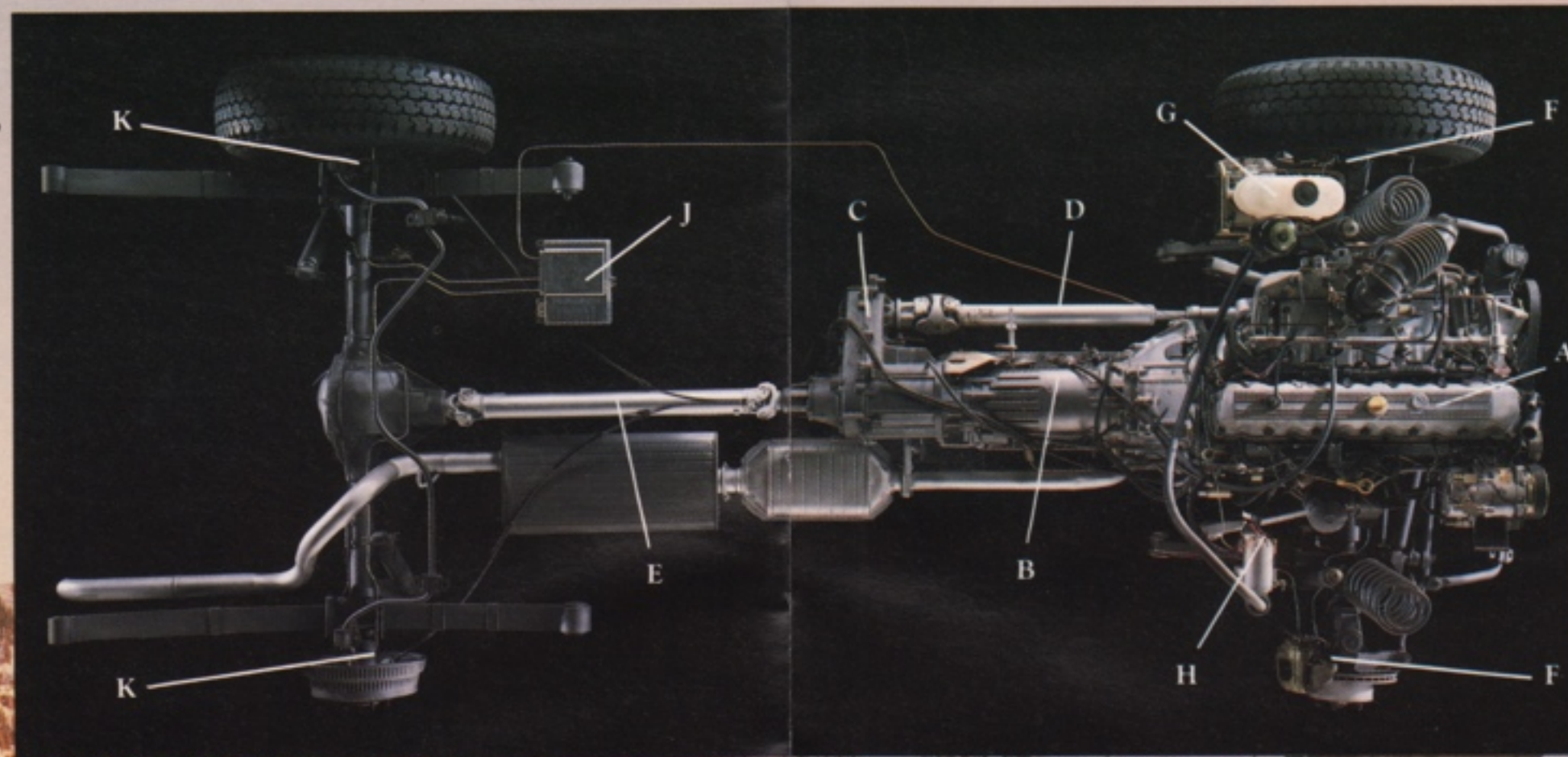

## Jeep Technology

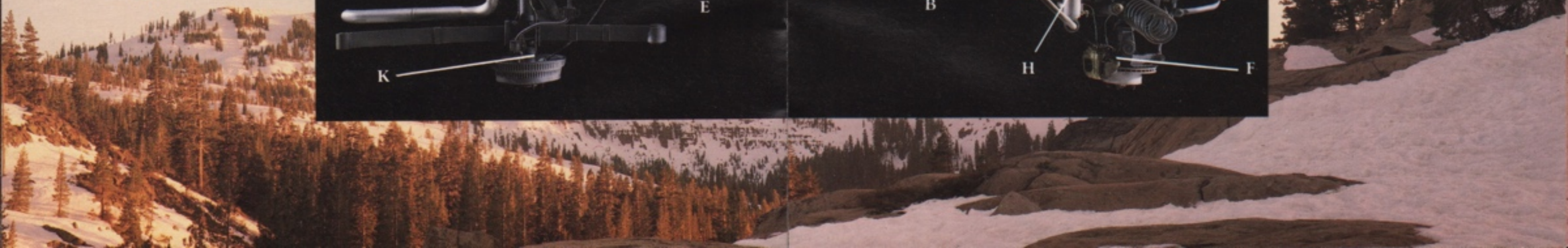



# Consider it an open invitation to explore brave new worlds.

Whatever environment you seek, Wrangler has the legendary Jeep prowess to get you up, out, and into it.

Control of the outback begins with Command-Trac, Jeep's part-time shift-on-the-fly four-wheel drive system. Plus, a ride-tuned suspension, 15"x7" wheels, P215/75R15 Goodyear Wrangler® tires, and power brakes. For improved off-road ruggedness



Jeep Wrangler Sahara

and durability, Wrangler features standard protective skid plates for the transfer case and fuel tank. And for serious enthusiasts, Wrangler is available with an optional Off-Road Package.

Wrangler offers a standard 2.5 litre TBI 4-cylinder engine matched to a 5-speed manual overdrive transmission. Or there's an optional 4.2 litre 6-cylinder (standard on Laredo), which can also be matched to an optional 3-speed automatic.

Inside, Wrangler is surprisingly civilized with full instrumentation, a long list of standard and optional

Jeep Wrangler



features, and plenty of room for four people and their gear. But nowhere is Wrangler's true nature more apparent than out in the open air with the standard soft top removed. That's everyday driving enjoyment in classic Wrangler style. Wrangler is also available with an optional hard top that's standard on the Laredo model.

This year, there's the all-new Wrangler Islander that offers a standard charcoal soft top (or optional hard top), full carpeting, net door map pockets, Islander striping and sunburst decal, four P215/75R15 outline white letter all-terrain radial tires, and spare tire cover with Islander design. The rest of the lineup includes Wrangler, Wrangler Base, Sahara, and Laredo models.



Jeep Wrangler Laredo

## Jeep® Wrangler

New Jeep Wrangler Islander





# Presenting a very solid argument for taking the long way home.

The long way home is very often a road less traveled or no road at all. And for those driving exceptions, Jeep offers the ideal driving alternative: Jeep Cherokee—4-Wheel & Off-Road magazine's only two-time winner of the coveted "4x4 of the Year" award.

Cherokee's award-winning status is hardly surprising when you consider all it has going for it. Like a choice of models with two or four doors, two- or four-wheel drive, and either of two shift-on-the-fly four-wheel drive systems. And Cherokee's unique Quadra-Link front suspension system that combines excellent ride and handling with all the ruggedness and versatility that have made Jeep world-famous.

Plus, power choices including a standard 2.5 litre TBI 4-cylinder engine and the optional 4.0 litre 6-cylinder Power-Tech Six that provides Class III 5000-pound trailer-towing capability. Both engines can be teamed with



4WD Jeep Cherokee Laredo four-door

either a standard 5-speed manual overdrive transmission or an optional 4-speed automatic overdrive (standard on Cherokee Limited). And for added driving security, the new optional four-wheel anti-lock brake system helps to prevent



brake lockup on slippery road surfaces.

Cherokee also covers a lot of ground with respect to occupants and their gear. The only domestic vehicle in its class with room for five adults, Cherokee offers 71.8 cubic feet of cargo space\*—again, best-in-class roominess for a domestic 4x4. There's an amazing array of standard and optional features as well, including a selection of premium audio systems. And you can choose from

five models—Base, Sport, Pioneer, Laredo, and Cherokee Limited.

This year, Jeep offers Cherokee Option Group Discounts that let you save on the features you want most by ordering options as a group rather than individually. See your Jeep dealer for details.

\*With rear seat folded down. According to EPA Volume Index.

## Jeep Cherokee



Left: 2WD Jeep Cherokee Pioneer four-door  
Right: Jeep Cherokee Limited two-door





# Stubborn is dedicating 49 years to the perfection of a single operating principle: driving security.

Jeep Wagoneers are two very special estate wagons that put driving security in a class all its own: the four-wheel drive luxury class.

Driving security for both Wagoneer Limited and Grand Wagoneer begins with Selec-Trac, Jeep's exclusive full-time shift-on-the fly four-wheel drive system. Standard Michelin® Tru-Seal puncture-resistant tires are designed to minimize the possibility of air loss caused by punctures in the tread area. And for an added measure of security, Wagoneer Limited is available with the optional new four-wheel

anti-lock brake system, which features independent sensors on all four wheels to help prevent brake lockup on slippery road surfaces.

Wagoneer Limited's exceptional ability begins with the 4.0 litre 6-cylinder



Jeep Grand Wagoneer

Jeep Wagoneer Limited



Among Wagoneer Limited's long list of standard driver amenities are a tilt steering column, leather-wrapped steering wheel, and Gauge Group.

Power-Tech Six matched to a 4-speed automatic overdrive transmission. Grand Wagoneer receives its brawn and hardy hauling power from a 5.9 litre V8. And each of these luxury-class 4x4s boasts Class III 5000-pound trailer-towing capability.

Inside, the operative word is *luxury*. Consider Wagoneer Limited. With four doors, room for five, 71.8 cubic feet of cargo space,\* and a long

list of driver and passenger conveniences, it offers as standard virtually everything you could ask for in a vehicle of its kind. And Grand Wagoneer, with its spacious comfort for six, 74.5 cubic feet of cargo space,\* and an unrivaled list of standard equipment, sits firmly at the top as the full-size grand classic in four-wheel drive luxury.

\*With rear seat folded down. According to EPA Volume Index.

## Jeep® Wagoneers



# Engineered for the high road, the low road, or no road at all.

It's one thing to be just a truck. It's quite another to be a Jeep Comanche. Available in two- or four-wheel drive, shortbed or longbed models, Comanche, like its legendary engineering, contains no halfway measures.

As winner in 1987 of the SCCA Racetruck Challenge and HDRA/SCORE class championships, Comanche's performance credentials are unquestionably world-class. Standard power is the race-proven 2.5 litre TBI 4-cylinder that puts out more horsepower and torque than any standard engine in its class. Or you can match this

class-leading status with the optional 4.0 litre 6-cylinder Power-Tech Six. And there's a choice of transmissions, including a 4-speed manual, a 5-speed manual overdrive, and a 4-speed automatic with overdrive.



Left to right: 2WD Jeep Comanche Eliminator, 4WD Jeep Comanche Pioneer shortbed, and 4WD Jeep Comanche Pioneer longbed



Mike Lesle's racing Comanche takes on the desert.

With the part-time four-wheel drive of Command-Trac, Comanche lets you shift on-the-fly between two- and four-wheel drive at any speed. Comanche is also available in rugged and durable two-wheel drive. But whatever model you choose, Comanche's strong UniFrame design and tough double-wall box construction provide both the 6- and 7-foot bed configurations with a standard

payload of 1475 pounds—more than most compact trucks' optional maximum capacities. And with the optional Big-Ton Payload Package, longbed models can carry up to 2205 pounds.

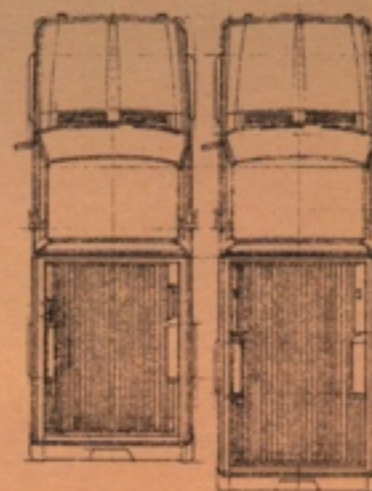

Comanche's 6-foot and 7-foot beds are among the largest in the compact class.

Comanche interiors are comfortable and functional. And for increased value, there are the Comanche Option Group Discounts. These special option groups

offer big savings on high-value options compared to ordering them individually. See your Jeep dealer for details.

## Jeep Comanche

4WD Jeep Comanche Pioneer shortbed







# Only in a Jeep<sup>®</sup>

- 
- 1989 Wrangler, Wrangler Base, Islander, Sahara, and Laredo.
  - Cherokee 2WD & 4WD Base, 2WD & 4WD Sport, 2WD & 4WD Pioneer, 2WD & 4WD Laredo, and 4WD Limited
  - Wagoneer Limited and Grand Wagoneer
  - Comanche 2WD & 4WD SporTruck, 2WD & 4WD Base Longbed, 2WD & 4WD Pioneer, and 2WD Eliminator
- 

Jeep supports the U.S. Forest Service and Bureau of Land Management's "Tread Lightly" Program, an educational tool designed to help promote public awareness of land use regulations and responsibilities in our nation's wilderness areas.

*All product illustrations and specifications are based upon current information at the time of publication approval. Although descriptions are believed correct, accuracy cannot be guaranteed. Chrysler Motors Corporation reserves the right to make changes from time to time, without notice or obligation, in prices, specifications, colors, and materials, and to change or discontinue models. See your dealer for details.*

Jeep, Wrangler, Sahara, Islander, Cherokee, Wagoneer, Grand Wagoneer, Comanche, Pioneer, Eliminator, Laredo, Limited, Quadra-Link, Selec-Trac, and Command-Trac are registered trademarks of Jeep Corporation.

To obtain our 1989 full-line catalog, The Jeep<sup>®</sup> Book, visit your Jeep dealer.

