

# 1980 OLDSMOBILE

DELTA 88 · CUSTOM CRUISER · NINETY-EIGHT · TORONADO



BUILT TO MAKE THE MOST OF EVERY MINUTE YOU DRIVE IN TODAY'S WORLD



# THE OLDSMOBILE COMMITMENT

“...to build one carriage in as nearly  
perfect a manner as possible...”

**W**ith these words, the Oldsmobile Motor Vehicle Company was founded on August 21, 1897. A fledgling company in a fledgling industry, committed to engineering excellence as the foundation for its existence.

And that has never changed. Hundreds of automotive nameplates have come and gone in the years since then. America has seen the motor-driven “carriage” evolve into its most popular mode of transportation. And Oldsmobile has emerged as America’s oldest automotive name—and one of the most renowned.

That’s worth considering when you choose your next new car. Because what Oldsmobile stands for could be just what you’re looking for.

## A HISTORY OF ENGINEERING LEADERSHIP

For 82 years, our commitment has inspired innovation after innovation which have improved the American automobile—and kept Oldsmobiles on the leading edge of technology through the years.

In the last two generations alone, we were first to offer these developments:

The first fully automatic transmission, to make driving easier than ever before.



- The first high-compression V8 production engine, to give America new levels of automotive performance.
- The first contemporary American front-wheel-drive automobile.

More recently, the engineering challenge has been to meet the changing needs of a fuel-conscious America. And Oldsmobile has responded with these developments in the last decade:

- New technology in developing and forming lighter-weight automotive components to improve weight efficiency.
- The world’s first passenger car diesel V8 in 1978, combining the fuel economy of a diesel\* with V8 smoothness and good performance.

Most recently, Olds has introduced new generations of more space- and fuel-efficient\* cars which offer improved gas mileage without sacrificing the ride, room

and comfort America expects in an Olds. First, the full-size 88 and 98 in 1977, the mid-size Cutlass in '78, Toronado in '79, and now Omega for 1980.

## THE PRIDE OF OWNING AN OLDS

There’s the name and the heritage. There’s also the integrity, quality and value you expect in an Olds.

But there must be more—we want you to feel that the Olds you choose so beautifully fits your particular needs and preferences that it seems especially built for you.

That’s why there are so many different kinds of Oldsmobiles, and so many ways they can be personalized, equipped and powered. Our purpose in this catalog is to help you choose the Oldsmobile that’s built for you—the one you’ll decide is one of the greatest cars you have ever owned or leased.

Seek it out. Drive it proudly.

## CONTENTS

INTRODUCTION.....	pp. 2-3
DELTA 88s.....	pp. 4-11
CUSTOM CRUISER.....	pp. 12-15
NINETY-EIGHT.....	pp. 16-21
TORONADO.....	pp. 22-25
OPTIONS AND ACCESSORIES.....	p. 26
THE FULL OLDSMOBILE LINE.....	p. 27

## Some words about this catalog and these 1980 Oldsmobiles

**About this catalog:** We have tried to make this catalog as comprehensive and factual as possible. However, since the time of printing, some of the information may have been changed or updated. The right is reserved to make changes at any time, without notice, in prices, colors, materials, equipment and models.

**About engines:** The Oldsmobiles shown in this catalog are equipped with GM-built engines produced by various divisions. See the various power team charts or your Oldsmobile dealer for details about sources and availability.

**About models illustrated:** Some of the equipment shown may be available only at extra cost, and only on specific models.

**About optional equipment:** Make certain you specify the equipment you want on your car when ordering it from your dealer. Some options may be unavailable when your car is built. Your dealer receives advice regarding current availability of options. You may ask the dealer for this information. GM also requests the dealer to advise you if an option you ordered is unavailable. We suggest you verify that your

car includes the optional equipment you ordered, or if there are changes, that they are acceptable to you.

**About assembly and components:** Oldsmobiles are assembled at General Motors Corporation facilities operated by various GM Divisions and GM of Canada. They incorporate thousands of different components produced by various divisions and various suppliers to GM. In order to meet public demand for particular vehicles or equipment, to meet federally mandated requirements for emissions, safety



# NEW ADVANCES IN FUEL ECONOMY

New aerodynamics, new high-pressure tires and new fuel efficiency combine for impressive gas mileage.

**W**ith the 1980 Ninety-Eight, Delta 88 and Custom Cruiser, Oldsmobile introduces sophisticated new ways to aid fuel economy without sacrificing performance, room or comfort.

## NEW EFFICIENCY IN DESIGN

The lean, clean new look was born of aerodynamic research and testing.

With tapered hood lines and squared-off rooflines, they cut the air with new efficiency—even the slight “lip” on the trunk lid contributes to reduced air resistance.

## NEW HIGH-PRESSURE TIRES

A new generation of steel-belted radial-ply tires is standard on these cars as well. They are specifically designed to reduce rolling resistance to aid fuel economy.

To accomplish this, they must be properly inflated to the pressure specified on the tires. Yet you will enjoy a soft, smooth ride you'd expect only with lower tire pressures. The suspension systems, body mounts and numerous other structures have been redesigned to preserve the kind of ride you expect in an Olds.

## IMPRESSIVE GAS MILEAGE\*

With these advances, plus refinements in engines, the 1980 Ninety-Eight, Delta 88

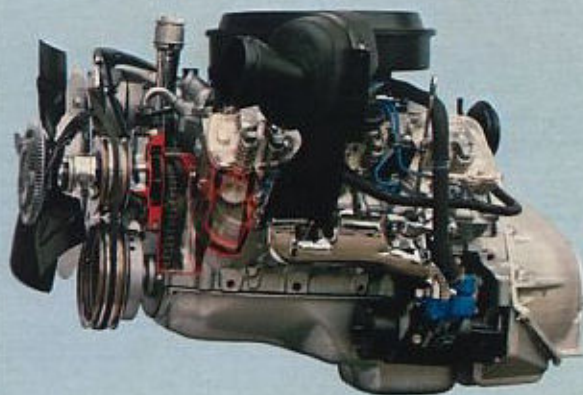

and Custom Cruiser continue to offer impressive EPA mileage estimates.\*

## NEW ADVANCES IN DIESEL PERFORMANCE

Two years ago, Oldsmobile startled the automotive world by introducing the world's first diesel V8 engine for passenger cars.

Today, Oldsmobile is America's number one seller of diesel cars.

Now Olds has incorporated significant improvements in diesel performance.

## FAST STARTS IN COLD WEATHER

First, a remarkable glow-plug system dramatically reduces the cold start time—from 60 seconds or more at 0°F for earlier diesel V8s, to about 8 seconds for all diesel-powered Oldsmobiles.

## QUIET DIESEL CRUISING

Diesel engines aren't traditionally known for quiet performance. For 1980, refinements in the camshaft, fuel injector nozzles, pre-chamber configuration and pump design have now hushed the V8 diesel to a point where you may scarcely realize you're cruising along in a diesel at all.

While diesel cars were not traditionally known for their response or smoothness, the 5.7-liter diesel-powered Oldsmobiles are impressive on both counts. Merging into expressway traffic—you'll find you can accelerate easily.

You'll be going a long way between fuel stops, too. Because you can expect substantially better fuel economy than with the same Olds with a gasoline engine.\*

## 21 DIESEL MODELS

Only Olds offers diesel V8 power in 21 different models—more than anyone else in America. Demand for diesel Oldsmobiles has been overwhelming. We are increasing our rate of production for 1980, and are making every effort to meet consumer demand.

So pick out the Olds that's right for you, and order it with diesel V8 power. You'll enjoy a great Olds all the more with diesel economy.\*

other reasons, it may be necessary to produce Oldsmobiles with different components or differently sourced components than initially scheduled. All such components have been approved for use in Oldsmobile products and will provide the quality performance associated with the Oldsmobile name. **Your Oldsmobile has these accident-avoidance features:** Side marker lights and reflectors □ Parking lamps that illuminate with headlamps □ Four-way hazard warning flasher □ Backup lights □ Lane-change feature in direction signal control □ Windshield

defrosters, washer and dual-speed wipers □ Wide-view inside mirror (vinyl edged, shatter-resistant glass and deflecting support) □ Outside rearview mirror □ Dual master cylinder brake system with warning light □ Starter safety switch □ Dual-action safety hood latches □ Front disc brakes with audible wear indicators □ Self-adjusting brakes.

**Your Olds has these occupant-protection features:** Seat belts with pushbutton buckles for all passenger positions □ Two front combination seat and inertia reel shoulder belts for driver (with reminder light and

buzzer) and right front passenger □ Energy-absorbing steering column □ Passenger guard door locks □ Safety door latches and stamped steel hinges □ Folding seat-back latches □ Energy-absorbing padded instrument panel and front seat-back tops □ Laminate windshield □ Safety armrests.

**Your Olds provides these built-in anti-theft features:** Anti-theft ignition key reminder buzzer □ Anti-theft steering column lock □ Anti-theft key system (one key for ignition only, other key for glove compartment, doors, trunk and tailgate).



ROYALE BROUGHAM

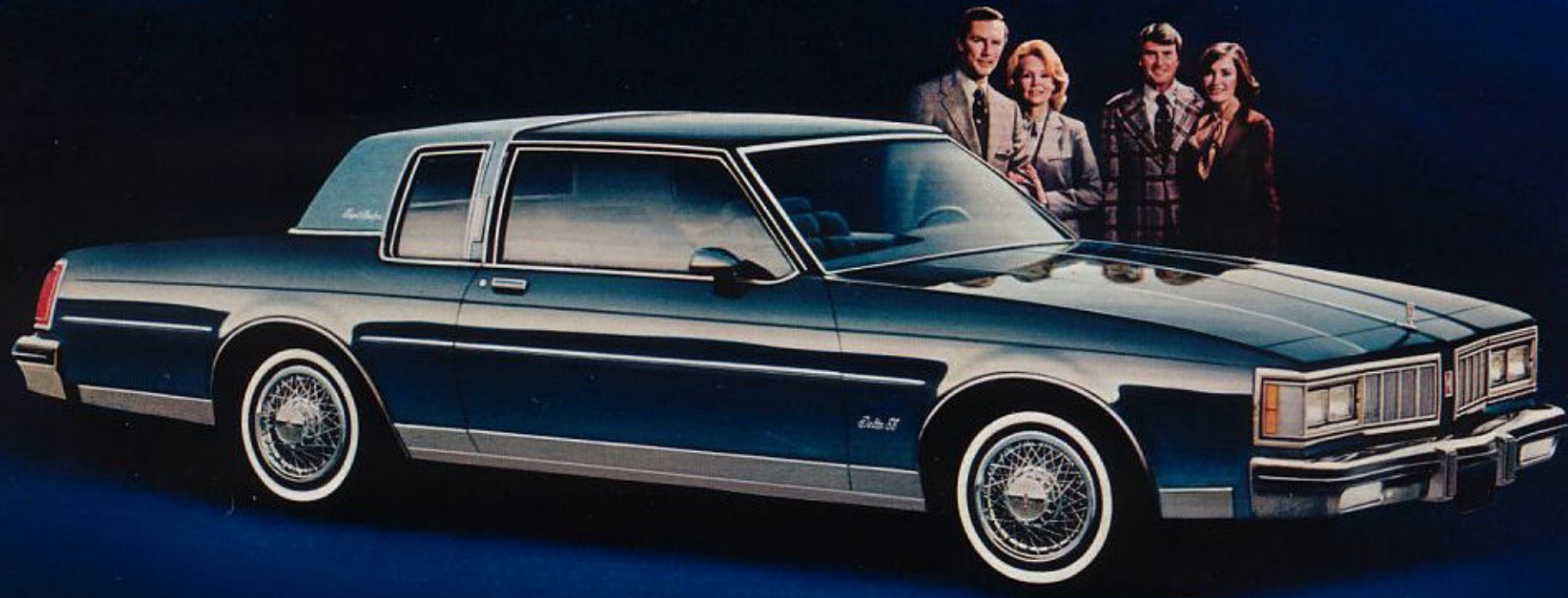

**DELTA 88**  
Our American family car  
is in great shape.

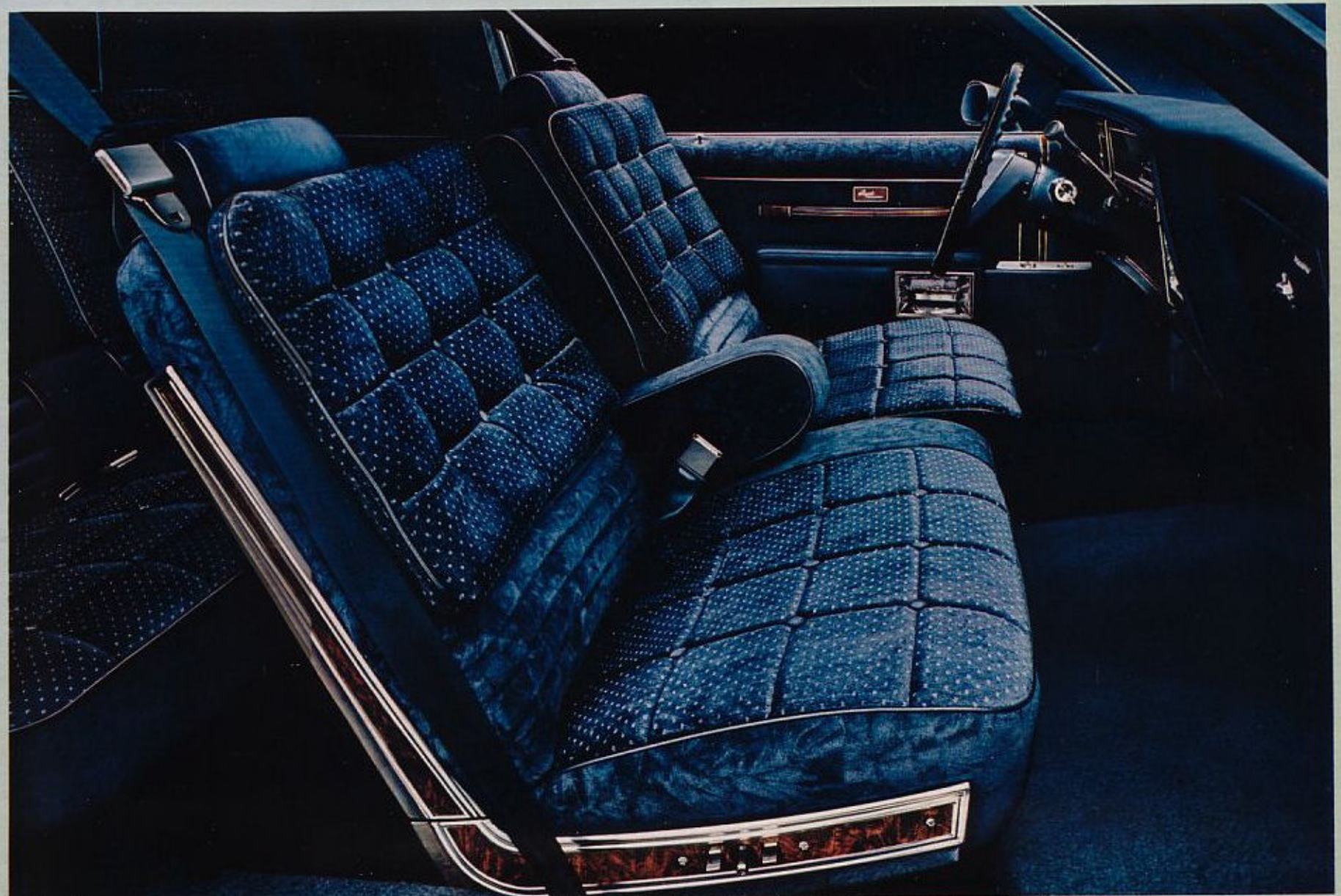

Divided front seat, front and rear center armrests, Lombardy and Lansdale velours, and luxurious room for six are all standard. Shown in Dark Blue.

ROYALE BROUGHAM



The Delta 88 Royale Broughams: Two elegant new top-of-the-line 88s that raise the level of luxury in American family cars. To all the practical values of an 88, Royale Brougham adds the elegance which could make this the most enjoyable full-size car you've ever owned or leased.



**Delta 88: A new shape for the '80s.** Delta 88 has always been a great family-size road car. Now it's been reshaped to be more aerodynamically efficient and more sophisticated in design than last year's Delta 88s, to aid fuel efficiency.\*

If these 88s look more streamlined to you, it's because they are. If they seem to move more easily over the road — they do. New high-pressure steel radial-ply tires have reduced rolling resistance — and they're standard. Yet the famous 88 ride is

still soft and smooth, thanks to re-engineered suspensions, shock absorbers and body mounts.

One thing more is standard in every 88 — the kind of gas mileage you need today!\*. And diesel V8 economy\* is available, too.

**The Delta 88 Royale Broughams:** Here's the ultimate in luxury in a Delta 88. The special Brougham interior provides velour upholstery, divided front seat with individual seat controls and center armrests, front and rear. (continued page 8)

## ROYALE



**Delta 88 Royale: A lot of luxury, a lot of comforts, room for six — plus impressive fuel efficiency for the '80s!\***



## ROYALE



A new aerodynamic look in full-size coupes, with tapered hood line and a touch of *Toronado* in the profile.

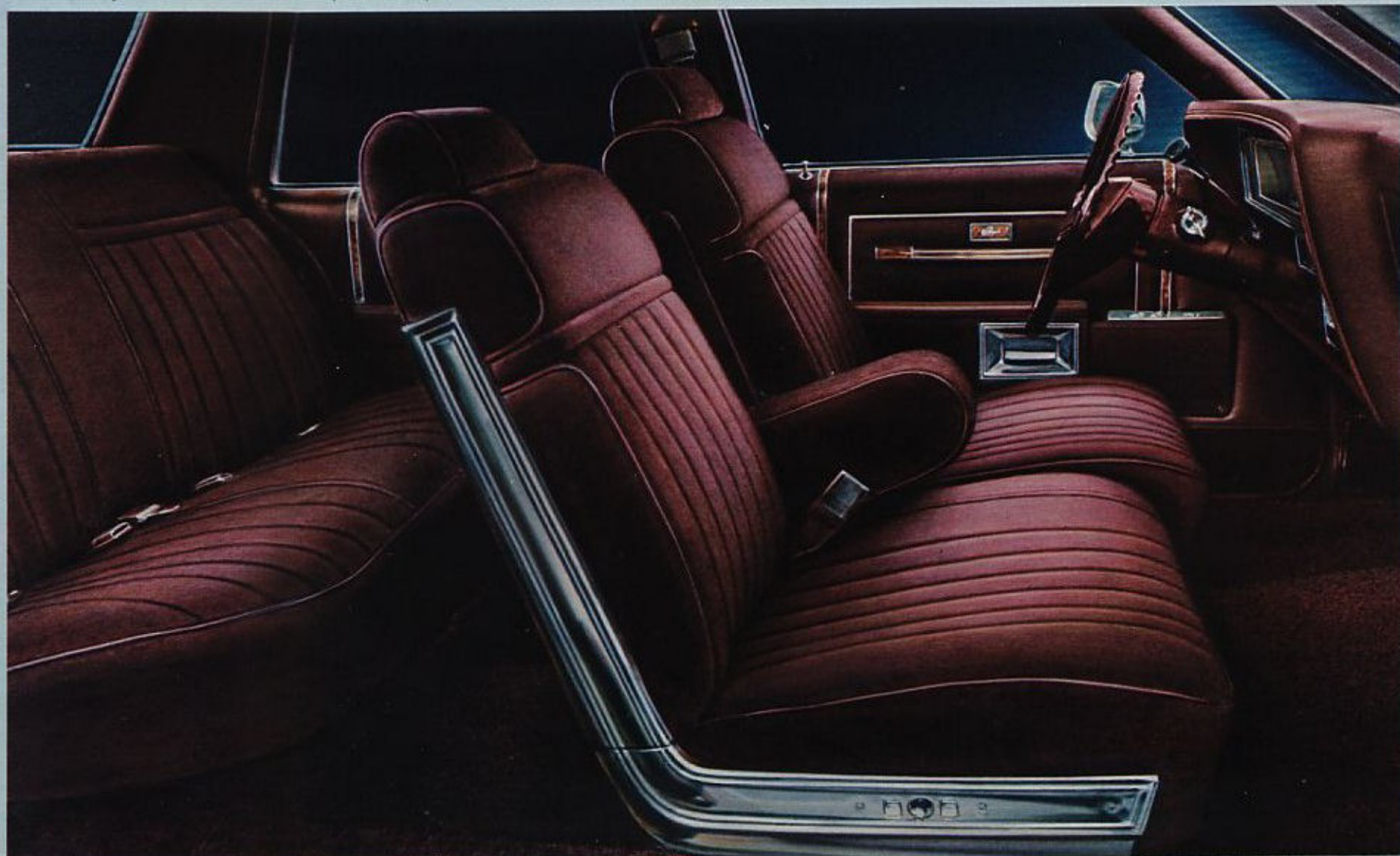

The Dark Claret color is new, and so is the tailoring of the magnificent Royale interior. Front center armrest is standard, of course. Divided seat available.



The way we see it, more luxury than you've ever had in an 88, plus more miles per gallon than you might expect,\* makes an unbeatable formula for driving in the '80s. Agreed?

**The Delta 88 Royale:** These are the 88s that are known for their handsome

interiors and deluxe comforts. Rich velour upholstery and front center armrest, of course. Generous headroom, legroom and kneeroom, front and rear. Outside, the beltline molding, the lower body molding with color-coordinated inserts, and wheel

discs are all standard. Add all this to the basic values of 88, and you've got a great family car. And you can have it with the available diesel V8, too!

**The Delta 88 Holiday Coupe:** Trade 6-passenger capacity for the flair of handsome bucket seats... add extra

sporty touches you don't expect in a full-size car. Like a T-bar shifter and a console, custom sport steering wheel, color-coordinated dual sport mirrors and painted wheel discs.

What you've got is a great road machine, upgraded with enough

## HOLIDAY COUPE



Delta 88 Holiday Coupe: Our bucket-seating, T-Bar-shifting, sporty-driving full-size road car. Shown with available landau roof.



Buckets in a full-size car? You bet! Shown in Dark Claret.

## HOLIDAY COUPE



Two-tone paint available — Super-Stock wheels and paint stripes, too.



brawn and size to satisfy those who prefer bigger cars.

That's the Holiday Coupe idea, and it's proving more popular every year. Now it's got slipstream styling and new high-pressure steel radials. And surprising fuel economy\* on the

road to boot. If you like sporty cars, try this one on for size and spirit. It looks and drives like it was born for the road!

**The basic Delta 88:** Compare it with its dollar-for-dollar competition and you're in for a pleasant surprise:

A Delta 88 is where you ought to be!

But don't stop there. Compare gas mileage, too. Delta 88 offers a choice of standard V6, three gasoline V8s and a diesel V8 — all with impressive EPA fuel efficiency ratings.\*

Another thing to compare is room

— Delta 88 has a lot of it, in front, in the rear and in the trunk.

Finally. There's basic Olds value to consider. Solid engineering. Quality. A lot of car for the money. With all this, shouldn't your next budget-priced family car be an 88? We think so, too.

## DELTA 88



Delta 88: Our lowest-priced 88s. Who said a budget-priced family car couldn't be a sleek, classy Olds?



The roomy 88 interior, in a handsome new Dark Blue.

## DELTA 88



The same great shape and value comes in a coupe, too.

\*See EPA mileage estimates in accompanying Engine Supplement Sheet. 9



## Delta 88 facts, figures and options.†

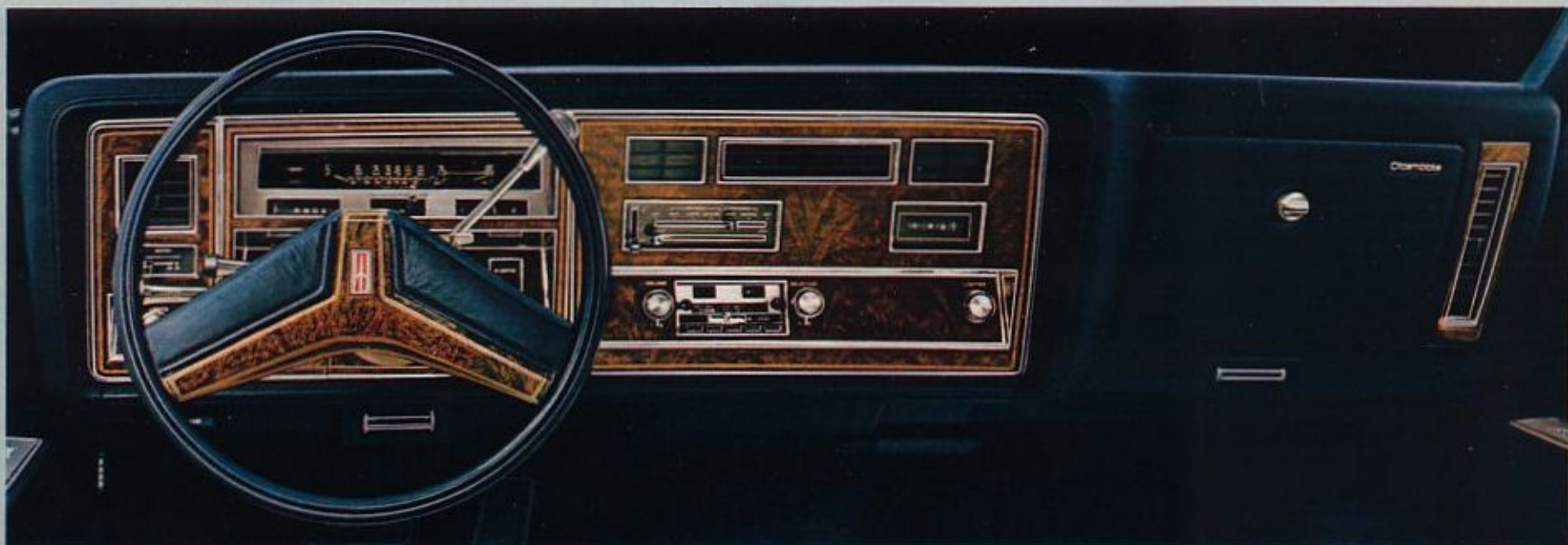

The Delta 88 command post. Up and down movement of the turn signal lever announces your turns; back and forth movement controls the high/low beam of the headlamps.



Yes, all that luggage fits into the trunk — over 20 cu. ft. of luggage space.



Extensive use of zinc-rich primers, wax sealers and anti-corrosion metals help provide extensive protection against rust.



Genuine leather seat and seat back inserts are available in Camel for the Royale Brougham. Individually controlled divided seats are standard.



Delta 88 makes the impressive fuel economy of a 5.7-liter diesel V8 available in every model.\*



Compaticolor interior in Oyster White is available with six contrasting colors for instrument panel and carpeting.

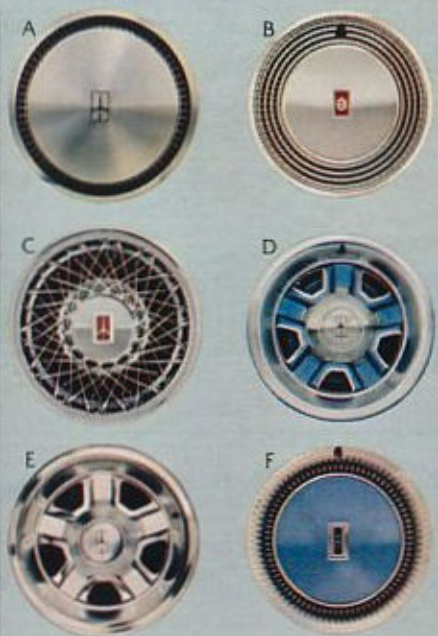

88 wheels and wheel discs. (A) Standard wheel disc. Available: (B) Deluxe disc, (C) simulated wire disc, (D) Super Stock III wheel with matching body color, (E) custom sport wheel and (F) deluxe disc with matching body color (Holiday only).



New this year are the jack locations under the side frame near each wheel, positioned for your convenience.



## STANDARD EQUIPMENT, ALL DELTA 88 MODELS:

### Chassis and body:

■ Full torque-beam frame construction  
 ■ Computer-selected chassis springs ■ Full coil suspension, front and rear ■ Body design altered to improve aerodynamics ■ High-pressure tires with reduced rolling resistance  
 ■ Extensive rust-resisting treatments and methods ■ Extensive applications of new anti-corrosion materials ■ Special lower body Plastisol application fights stone chipping  
 ■ Power front disc brakes ■ Power steering  
 ■ Electronic high-energy ignition system  
 ■ Recessed windshield wipers ■ Space-efficient trunk with compact spare tire and wheel ■ New side-lift jack location ■ Bumper impact strips and bumper guards, front and rear ■ Maintenance-free battery ■ Front-end panel stand-up ornament ■ Full wheel discs  
 ■ Outside rearview mirror, driver side ■ Bright rocker panel and wheel-opening moldings  
 ■ Roof drip moldings ■ Lock pillar applique molding (Coupe)

### Interior:

■ Full-foam seat construction ■ Armrests, front and rear ■ Cut-pile wall-to-wall carpeting  
 ■ Simulated Butterfly Walnut-grain instrument panel trim ■ Deluxe steering wheel ■ Courtesy lamps, automatic door actuated ■ Cigar lighter, instrument panel ■ Bright accents on accelerator and brake pedals ■ Inside day-night rearview mirror ■ Interior-operated hood lock release ■ Dual front seat head restraints  
 ■ Seat belts for all passenger positions  
 ■ Flo-thru ventilation ■ Bench front seat in choice of cloth or vinyl

## STANDARD EQUIPMENT BY MODEL:

### Delta 88:

■ Engine, 3.8-liter (231 CID) V6, 2-bbl.  
 ■ Transmission, 3-speed fully automatic column shift ■ Tires, P205/75R15 steel-belted radial-ply blackwall

### Delta 88 Holiday Coupe:

■ Contour bucket front seats ■ Sports console with T-bar shifter ■ Custom sport steering wheel ■ Dual sports mirrors ■ Painted wheel discs ■ Specific Holiday identification

### Delta 88 Royale:

■ Engine, 3.8-liter (231 CID) V6, 2-bbl.  
 ■ Transmission, 3-speed fully automatic column shift ■ Tires, P205/75R15 steel-belted radial-ply blackwall ■ Moldings, body side  
 ■ Custom sport bench seat with fold-down center armrest in velour

### Delta 88 Royale Brougham:

■ Engine, 3.8-liter (231 CID) V6, 2-bbl.  
 ■ Transmission, 3-speed fully automatic column shift ■ Tires, P205/75R15 steel-belted radial-ply blackwall ■ Moldings, belt reveal, body side ■ Lock pillar opera lamp (Coupe)  
 ■ Divided bench seat with individual controls, in velour

## AVAILABLE EQUIPMENT:

- V8 power trains, see below
- 6-way power seat adjuster, bucket seat only—driver side (Holiday Coupe)
- Deluxe seat belts—color-keyed to interior
- 6-way power seat adjusters, driver and passenger sides with divided seat only (Royale and Royale Brougham)
- Divided front seat with individual controls (Royale and Royale Brougham)
- Reclining seat back—passenger side
- Power door locks

- Soft-ray tinted glass
- 6-way power seat adjuster—bench seat
- Electric trunk-lid lock release
- Lower body side moldings
- Auxiliary floor mats, front and rear—with carpet inserts if desired
- Luggage compartment rubber floor mat
- Deluxe trunk trim and spare tire cover
- Moldings: body side and bright door-edge guards: belt reveal (Royale)
- Electric sunroof, glass or metal panel
- Pulse wiper system
- Padded vinyl landau rooftop covering (Coupes) or full vinyl covering (Sedans and Coupes)
- Electric rear window defogger
- Four-Season or Tempmatic air conditioner
- Lock pillar opera lamp (Coupes only)
- Combination dome, dual reading lamps
- Front door locks and interior illumination package
- Mirrors outside rearview manual remote control, driver side only passenger side only, plus driver and passenger sides: electronically operated, driver and passenger sides
- Litter container
- Upper body accent stripe
- Limited-slip differential
- Engine block heater
- Automatic Cruise Control
- Tilt-away or Tilt-and-Telescope steering wheel
- Super-Stock III wheels, color-matched to body
- Custom chrome sport wheels
- Simulated wire wheel discs, regular or with locks
- Tungsten halogen headlamps—high beams
- Twilight sentinel
- Cornering lamps

- High-capacity battery
- Theft-deterrent system
- Electric clocks: regular, digital or digital fluorescent
- AM, AM-FM monaural, AM-FM stereos
- AM pushbutton radio with stereo tape player and 2 rear speakers
- AM-FM stereo pushbutton radio with stereo tape and 2 rear speakers
- AM-FM stereo pushbutton radio with cassette tape player and 2 rear speakers
- AM-FM stereo pushbutton radio, 40-channel CB, stereo tape player, with automatic power antenna and 2 rear speakers
- AM-FM stereo pushbutton radio, 40-channel CB, automatic antenna, 2 rear speakers
- Automatic front fender antenna
- Instrument panel gage cluster
- Trip odometer
- External lamp monitor, front and rear
- Convenience group, lamps and mirror
- Custom leather trim (Royale Brougham)
- Special indicator reminder package
- Special lower body paint scheme
- Holiday Coupe package (Delta 88 only)
- Tires, P205/75R15 steel-belted radial-ply white-stripe
- Tires, P215/75R15 steel-belted radial-ply white-stripe

## AVAILABLE SPECIAL USE EQUIPMENT:

- Rallye suspension package (with V8 option)
- Heavy-duty suspension system
- Automatic leveling system
- High-capacity Delcotron
- Heavy-duty wheels
- Special trailer electrical wiring harnesses
- High-capacity cooling system
- Heavy-duty engine cooling system

## Delta 88: Built and backed with a great engineering heritage.

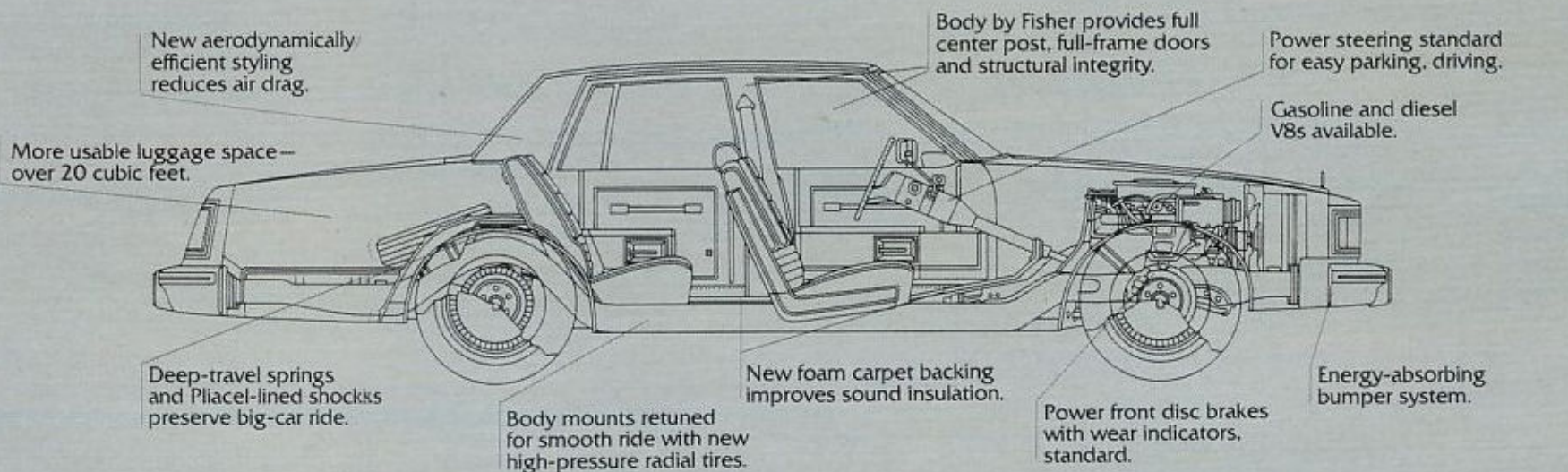

### POWER TRAINS<sup>1</sup>

Standard engine:	
■ Liter/CID/Type	3.8/231/V6
Carb./Std. axle ratio	2-bbl/2.73
Available engines:	
□ Liter/CID/Type	4.3/265/V8
Carb./Std. axle ratio	4-bbl/2.56
□ Liter/CID/Type	5.0/307/V8
Carb./Std. axle ratio	4-bbl/2.41

□ Liter/CID/Type	5.7/350/V8
Carb./Std. axle ratio	4-bbl/2.41
□ Liter/Type	5.7/diesel V8
Std. axle ratio	2.41
Standard transmission	Automatic
Fuel tank capacity (gal.)	
Gasoline	20.7/25.0
Diesel	27.0

### DIMENSIONS (Sedan)

Length (in.)	218.4
Width (in.)	76.3
Height (in.)	54.7
Wheelbase (in.)	116.0
Tread—front (in.)	61.7
rear (in.)	60.7
Wheel size—std. (in.)	15 x 6
Tire size—std.	P205/75R15

Curb weight (lbs.) 3488-3510

### INTERIOR DIMENSIONS (Sedan)

Front:	
Legroom (in.)	42.2
Headroom (in.)	*39.5
Shoulder room (in.)	60.9
Rear:	
Legroom (in.)	39.1
Headroom (in.)	*38.2

Shoulder room (in.) 60.9

Trunk capacity (cu. ft.) 20.8

<sup>1</sup>Check your Engine Supplement Sheet for details; standard and available equipment may differ in California. Additional copies at your Oldsmobile dealer's.

\*Reduced slightly with sliding sunroof.





# CUSTOM CRUISER

The luxurious, smooth-riding, full-size Oldsmobile that works like a wagon—whenever you want.



The Custom Cruiser interior with velour upholstery, like a luxury sedan, is available at no extra cost. Available divided seat shown, in Camel Tan.

## CUSTOM CRUISER



The more economical version of Custom Cruiser, minus the available wood-grain vinyl panels. A lot of room for cargo, a lot of comfort for six, and a certain fresh flair created by the new tapered hoodline.



## Custom Cruiser facts, figures and options.†



You can choose this handsome vinyl upholstery for your Custom Cruiser, or the velour trim on page 13 – no extra charge.

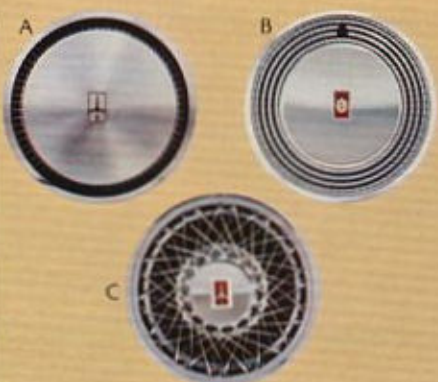

Cruiser wheel discs. (A) Standard, (B) Deluxe and (C) simulated wire discs, available.



Lockable hideaway for small valuables.



New foam-backed plush carpeting brings living room luxury to Custom Cruiser. Three-way tailgate drops or opens from the side, as shown.



Room: 87 cubic feet of it, with the second seat down. Wide enough to swallow a four-foot panel.



Need room for more than six? This third seat is available to carry a couple more. It folds down when you need the load space.



## CUSTOM CRUISER STANDARD EQUIPMENT:

### Chassis and body:

■ Electronic high-energy ignition system ■ Power brakes with front discs ■ Power steering ■ Full-coil suspension, front and rear ■ Torque-beam full frame ■ High-pressure tires with reduced rolling resistance ■ Heavy-duty wheels ■ Bumper impact strips plus bumper guards, front and rear with inserts ■ Extensive usage of special anti-corrosion materials and treatments ■ Special lower body Plastisol application fights stone chipping ■ Maintenance-free battery ■ Rear storage compartment with lock ■ Spare tire extractor ■ Side-frame jacking system

### Interior:

■ Armrest bench front seat ■ Full-foam cushions throughout ■ Cut-pile carpeting, lower door panels plus cargo area ■ Simulated Butterfly Walnut-grain instrument panel trim ■ Tailgate-ajar warning lamp, instrument panel ■ Electric tailgate window, driver control ■ Three-way tailgate operation ■ Cigar lighter, instrument panel ■ Interior-operated hood lock release ■ Instrument panel courtesy lamps and automatic switches ■ Seat belts for all passenger positions ■ Rear seat fold-down provision ■ Deluxe steering wheel ■ Flo-thru ventilation ■ Transmission, 3-speed fully automatic

### ADDITIONAL STANDARD EQUIPMENT:

■ Engine, 5.0-liter (307 CID) V8, 4-barrel

■ Transmission, 3-speed fully automatic  
■ Moldings: bright roof drip, bright side window, wheel-opening and rocker panels, belt reveal ■ Tires, P225/75R15 steel-belted radial-ply blackwall ■ Full wheel discs

### AVAILABLE EQUIPMENT:

- Power trains, see below
- 6-way power seat adjuster, driver side with divided seat
- 6-way power seat adjuster, passenger side with divided seat
- Deluxe seat belts, color-matched to interior
- Divided front seat with individual controls
- Rear-facing third seat, includes rear bumper step
- Reclining seat back, passenger side
- Power door locks, includes tailgate lock
- Soft-ray tinted glass
- Power side windows
- Lower body side moldings
- Body side and tailgate Walnut-grain vinyl panels
- Auxiliary floor mats, front and rear
- Auxiliary floor mats, front and rear with carpet inserts
- Body side moldings
- Bright door-edge guard moldings
- Pulse wiper system
- Electric rear window defogger
- Four-Season air conditioner
- Tempmatic air conditioner
- Combination dome and dual-lens reading

- lamp
- Illumination package, door locks and interior
- Mirror, remote control outside rearview, passenger side
- Mirrors, electrically operated outside rearview, driver and passenger sides
- Mirror, remote control outside rearview, driver side
- Mirror, sport-styled remote control outside rearview, driver side; passenger side manual
- Mirror, illuminated visor vanity, passenger side
- Mirrors, sport-styled outside rearview remote control, driver and passenger sides
- Litter container
- Limited-slip differential
- Engine block heater
- Automatic Cruise Control
- Tilt-Away steering wheel
- Tilt-and-Telescope steering wheel
- Simulated wire wheel disc
- Simulated wire wheel disc with lock
- Deluxe wheel disc
- Tungsten halogen headlamps, high beams
- Twilight sentinel
- Cornering lamps
- High-capacity battery
- Digital fluorescent electric clock
- Digital electric clock
- Electric clock
- AM pushbutton radio with stereo tape player and 2 rear speakers
- AM-FM stereo pushbutton radio with

- stereo tape player and 2 rear speakers
- AM-FM stereo pushbutton radio with cassette tape player and 2 rear speakers
- AM-FM stereo pushbutton radio, 40-channel CB, stereo tape player, automatic power front fender antenna and 2 rear speakers
- AM-FM stereo pushbutton radio with 2 rear speakers
- AM pushbutton radio
- AM-FM monaural pushbutton radio
- AM-FM stereo pushbutton radio with 40-channel CB
- Instrument panel gage cluster
- Trip odometer
- External lamp monitor, front and rear
- Automatic power front fender antennas
- Radio speakers, rear seat, single and dual
- Rear bumper step, included in third seat package
- Rooftop luggage carrier, includes rear window air deflector
- Convenience group, lamps and mirrors
- Reminder package, indicators
- Tires, P225/75R15 steel-belted radial-ply white-stripe

### AVAILABLE SPECIAL USE EQUIPMENT:

- Heavy-duty suspension system
- Automatic leveling system
- High-capacity Delcotron
- Trailer electrical wiring harnesses—5- and 7-wire
- High-capacity engine cooling system

Under the luxury solidly engineered for sedan-like comfort.

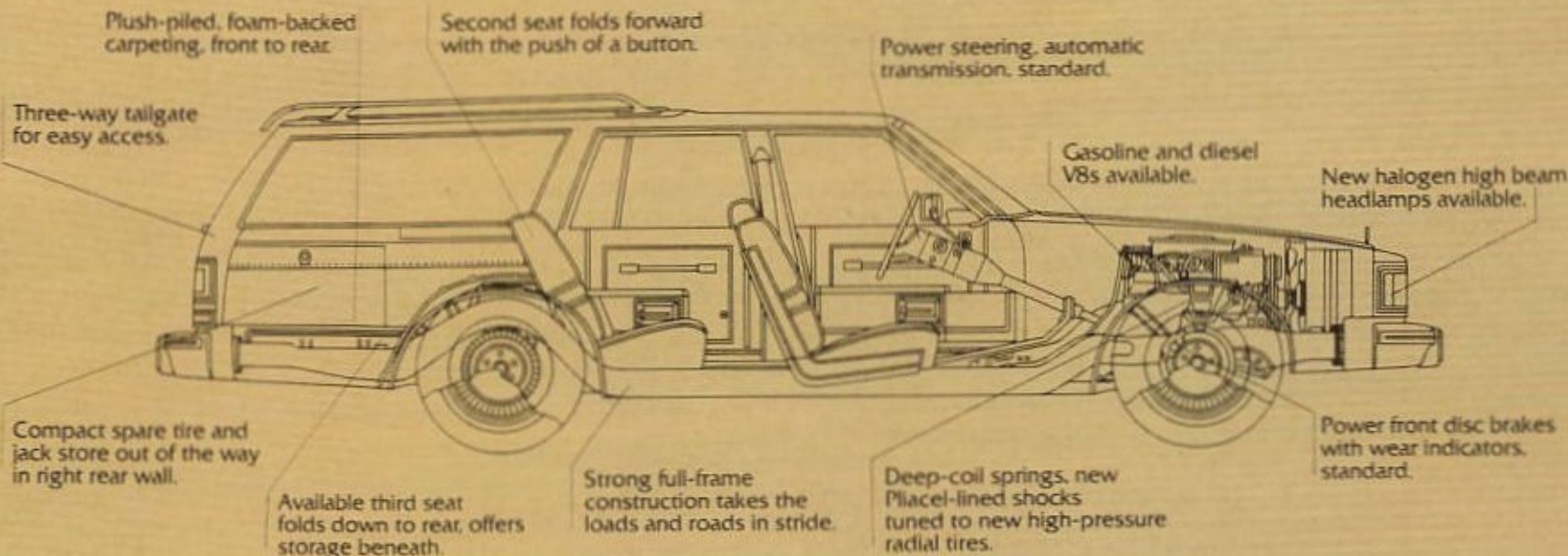

### POWER TRAINS

Standard engine:	
■ Liter/CID/Type	5.0/307/V8
Carb./Std. axle ratio	4-bbl./2.56
Available engines:	
<input type="checkbox"/> Liter/CID/Type	5.7/350/V8
Carb./Std. axle ratio	4-bbl./2.56
<input type="checkbox"/> Liter/Type	5.7/diesel V8

Std. axle ratio	2.73
Standard transmission	Automatic
Fuel tank capacity (gal.)	
Gasoline	22.0
Diesel	22.0
<b>DIMENSIONS</b>	
Length (in.)	219.4
Width (in.)	79.8
Height (in.)	56.6

Wheelbase (in.)	116.0
Tread—front (in.)	62.1
Tread—rear (in.)	64.1
Wheel size—std. (in.)	15 x 7
Tire size—std.	P225/75R15
Curb weight (lbs.)	4062
<b>INTERIOR DIMENSIONS</b>	
Front:	
Legroom (in.)	42.2

Headroom (in.)	39.6
Shoulder room (in.)	60.6
Rear:	
Legroom (in.)	37.8
Headroom (in.)	39.3
Shoulder room (in.)	60.5
Cargo area:	
Max. cargo area (cu. ft.)	87.2
Max. floor length (in.)	90.2

Floor length, 2nd seat up	55.4
Min. width, at floor (in.)	48.2
Rear opening width (in.)	48.2
Max. rear opening height	28.7
Cargo height inside (in.)	29.7

\*Check your Engine Supplement Sheet for details, standard and available equipment may differ in California. Additional copies at your Oldsmobile dealer's.



REGENCY



# NINETY-EIGHT

Of the world's great luxury cars, this could be your most logical choice.



The Regency interior with divided front seat, front and rear center armrests, and velour upholstery, all standard. Shown in Dark Claret. Sit down, down, down.

REGENCY



**Ninety-Eight Regency: Oldsmobile's ultimate full-size luxury car.** A new sophistication for the '80s. Traditionally spacious and comfortable. Yet improved in rolling resistance and aerodynamics over last year. And priced substantially less than many of its peers, whether you buy or lease.



LUXURY SEDAN



**Ninety-Eight LS Sedan: The luxury is obvious; the logic lies in its surprisingly good gas mileage\* and sensible price.**



**Remarkably practical for all its luxury.** For 1980, the best news is that Ninety-Eight fuel economy is impressive\* — through aerodynamic sculpturing, weight reduction, new fuel-conserving high-pressure steel radial-ply tires and new standard

engine. The ride system has been reengineered to preserve the comfortable ride you expect in a 98. **The Ninety-Eight Regency:** Inside its new shape, the famous Regency hallmarks remain: the loose-pillow-look seatbacks, the plush velour, the

high-styled treatment of the door panels. This is the ultimate luxury Oldsmobile — compare it to other luxury cars priced thousands of dollars more.

**The Ninety-Eight LS Sedan:** When you discover that our lowest-priced

Ninety-Eight provides such amenities as air conditioning, power windows, power seat control, even dual remote control side mirrors as standard equipment, you'll be impressed by the value. Then be impressed, take a test drive, and let logic prevail.



LS interior in Camel. Impressive headroom, legroom and knee clearance. Dollar for dollar, this could be America's best luxury car value.



## Ninety-Eight facts, figures and options.†



Clarity, convenience and fingertip control against a background of simulated butterfly walnut mark the Ninety-Eight instrument panel.



Over 20 cubic feet of luggage space accommodates all the luggage shown.



Soft, luxurious leather inserts in seats and seat backs are available in Dark Claret, Camel Tan and Black interiors for Ninety-Eight Regency models.



A boon to traveling is this available passenger's reclining seat back. Very restful. New reclining seat back power adjustment also available.

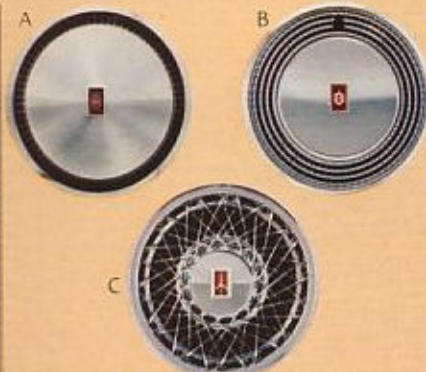

98 wheel discs. (A) Standard. (B) Deluxe and (C) simulated wire discs, available.



Metal or tinted glass electric sunroof available (reduces headroom slightly).



The driver's door console clusters controls at your fingertips.



## NINETY-EIGHT STANDARD EQUIPMENT:

### Chassis and Body:

■ Torque-beam frame ■ Computer-selected chassis springs ■ Full-coil suspension, front and rear ■ Body design altered to improve aerodynamics ■ High-pressure tires with reduced rolling resistance ■ Extensive rust-resisting treatments and methods ■ Extensive applications of new anti-corrosion materials ■ Special lower body Plastisol application fights stone chipping ■ Power front disc brakes ■ Power steering ■ Electronic high-energy ignition system ■ Recessed windshield wipers ■ Space-efficient trunk with compact tire and wheel; deluxe trim and wheel cover (Regency) ■ New side-lift jack location ■ Bumper impact strips and bumper guards, front and rear ■ Maintenance-free battery ■ Dual remote-control mirrors ■ Rear fender skirts ■ Full wheel discs ■ Moldings: bright roof drip, rocker panel and wheel-opening ■ Hood ornament

### Interior:

■ Full-foam seat construction throughout ■ Armrests, front and rear, with power controls integral front ■ Four-Season air conditioner ■ Armrest bench front seat (Luxury Sedan) ■ Divided bench front seat with individual controls (Regency) ■ Cut-pile carpeting wall-to-wall plus lower door panels ■ Simulated Butterfly Walnut-grain instrument panel trim ■ Cigar lighter, instrument panel ■ Electric clock (digital Regency) ■ Interior-operated hood lock release ■ AM-FM stereo radio with 2 rear speakers (Regency) ■ Power 2-way seat adjuster, driver side ■ Power side windows

■ Deluxe steering wheel ■ Deluxe seat belts for all passengers ■ Flo-thru ventilation

### OTHER STANDARD EQUIPMENT:

■ Engine, 5.0-liter (307 CID) V8, 4-barrel ■ Transmission, 3-speed fully automatic ■ Tires, P215/75R15 steel-belted radial-ply blackwall ■ Sail panel opera lamp (Regency)

### AVAILABLE EQUIPMENT:

Power trains, see below  
 Six-way power seat adjuster  
 Reclining seat back, passenger side  
 Power door locks  
 Soft-ray tinted glass  
 Power trunk-lid lock release  
 Auxiliary floor mats, front and rear  
 Auxiliary floor mats, front and rear with carpet inserts  
 Luggage compartment floor mat  
 Body side molding and bright door-edge guard moldings  
 Sunroof, electric sliding metal panel  
 Astrorooftop, electric sliding tinted glass panel  
 Full vinyl padded rooftop covering (Sedans)  
 Landau vinyl rooftop covering (Coupe)  
 Pulse wiper system  
 Electric rear window defogger  
 Tempmatic air conditioner  
 Sail panel reading lamps (Sedans)  
 Combination dome and dual lens reading lamp  
 Illumination package, front door locks and interior  
 Electrically operated outside rearview mirrors, driver and passenger side  
 Litter container

Illuminated visor vanity mirror, passenger side  
 Outside rearview mirror, remote control with thermometer, driver side  
 Accent stripe, body side  
 Limited-slip differential  
 Engine block heater  
 Automatic Cruise Control  
 Tilt-Away steering wheel  
 Tilt-and-Telescope steering wheel  
 Simulated wire wheel disc  
 Simulated wire wheel disc with lock  
 Deluxe wheel disc  
 Tungsten halogen headlamps, high beam  
 Twilight sentinel  
 Cornering lamps  
 High-capacity battery  
 Digital fluorescent clock, elapsed timer  
 Digital clock (std. on Regency)  
 AM pushbutton radio with stereo tape player and 2 rear speakers (LS only)  
 AM-FM stereo radio with stereo tape player and 2 rear speakers  
 AM-FM electronically tuned stereo radio with electronic digital display clock, 40-channel CB, automatic power antenna and 2 rear speakers  
 AM-FM electronically tuned stereo radio with electronic digital display clock, stereo tape player and 2 rear speakers  
 AM-FM electronically tuned stereo radio, electronic digital display clock, 40-channel CB, stereo tape player, automatic power antenna and 2 rear speakers  
 AM-FM electronically tuned stereo radio, electronic digital display clock, cassette tape player, 2 rear speakers  
 AM-FM electronically tuned stereo radio with electronic digital display clock and 2 rear speakers

AM-FM stereo radio with cassette tape player and 2 rear speakers  
 AM-FM electronically tuned stereo radio, electronic digital display clock, cassette tape player, 40-channel CB, power antenna, 2 rear speakers  
 AM-FM stereo, 40-channel CB with stereo tape player, automatic antenna and 2 rear speakers  
 AM-FM stereo radio with 40-channel CB, automatic power antenna and 2 rear speakers  
 AM-FM stereo radio with 2 rear speakers (LS Sedan only)  
 AM radio (Luxury Sedan)  
 Instrument panel gage cluster  
 Trip odometer  
 External lamp monitor, front and rear  
 Automatic power front fender antenna  
 Special Firemist exterior paints  
 Custom leather interior trim (Regency)  
 Convenience group, lamps and mirrors  
 Reminder package, indicators and warning reminders  
 Special lower body paint scheme  
 Tires, P215/75R15 steel-belted radial-ply white-stripe  
 Tires, P225/75R15 steel-belted radial-ply white-stripe

### AVAILABLE SPECIAL USE EQUIPMENT:

Heavy-duty suspension  
 Automatic leveling system  
 High-capacity Delcotron  
 Heavy-duty wheels  
 Trailer electrical wiring harnesses (5-wire and 7-wire)  
 High-capacity engine cooling system

## Ninety-Eight: Luxury engineered with logic.

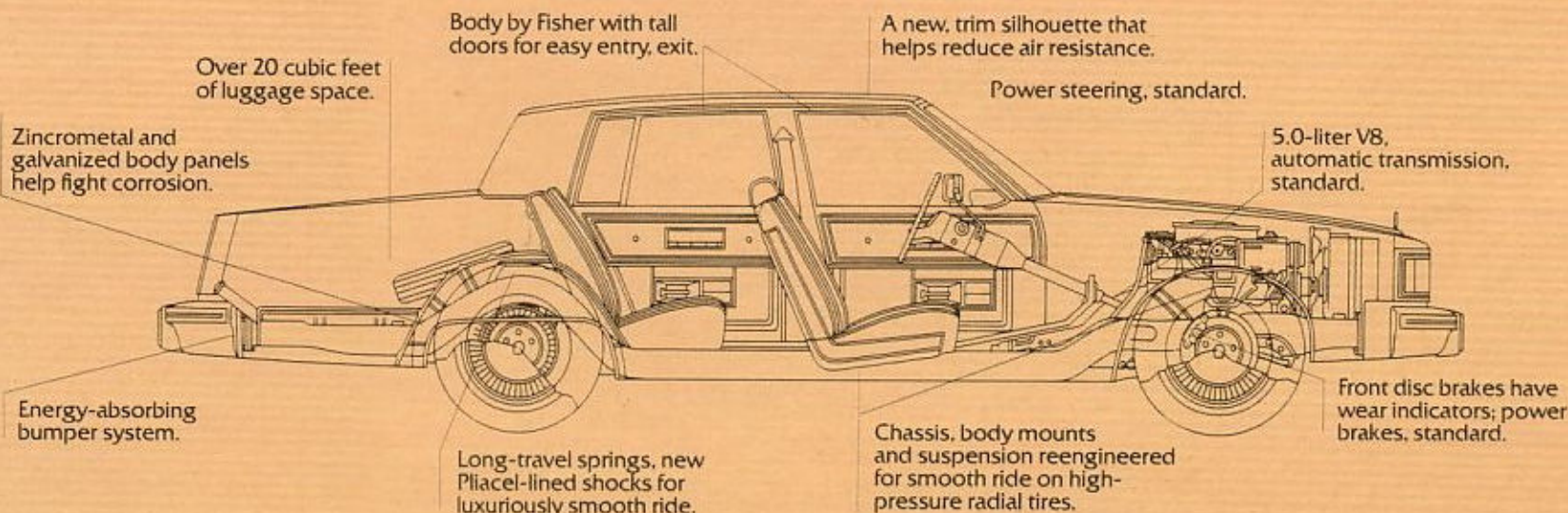

### POWER TRAINS\*

Standard engine:  
 ■ Liter/CID/Type ..... 5.0/307/V8  
 Carb./Std. axle ratio ..... 4-bbl/2.41  
 Available engines:  
 Liter/CID/Type ..... 5.7/350/V8  
 Carb./Std. axle ratio ..... 4-bbl/2.41  
 Liter/Type ..... 5.7/diesel V8

Std. axle ratio ..... 2.41  
 Standard transmission ..... Automatic  
 Fuel tank capacity (gal.) ..... 25.0  
 Gasoline ..... 27.0  
 Diesel

### DIMENSIONS (Sedan)

Length (in.) ..... 221.4

Width (in.) ..... 76.3  
 Height (in.) ..... 55.3  
 Wheelbase (in.) ..... 119.0  
 Tread - front (in.) ..... 61.7  
           rear (in.) ..... 60.7  
 Wheel size - std. (in.) ..... 15 x 6  
 Tire size - std. .... P215/75R15  
 Curb weight (lbs.) ..... 3943-3990

### INTERIOR DIMENSIONS (LS Sedan)

Front:  
 Legroom (in.) ..... 42.2  
 Headroom (in.) ..... \*39.5  
 Shoulder room (in.) ..... 60.8  
 Rear:  
 Legroom (in.) ..... 41.9  
 Headroom (in.) ..... \*38.1

Shoulder room (in.) ..... 61.0  
 Trunk capacity (cu. ft.) ..... 20.8

\*Check your Engine Supplement Sheet for details; standard and available equipment may differ in California. Additional copies at your Oldsmobile dealer's.

\*Reduced slightly with sliding sunroof.





**TORONADO**  
Our state of the art in  
personal luxury cars.



Brougham's loose-pillow look in velour upholstery creates a private island of luxury and quiet. Shown in the new Dark Brown.

**XSC SPORT COUPE**

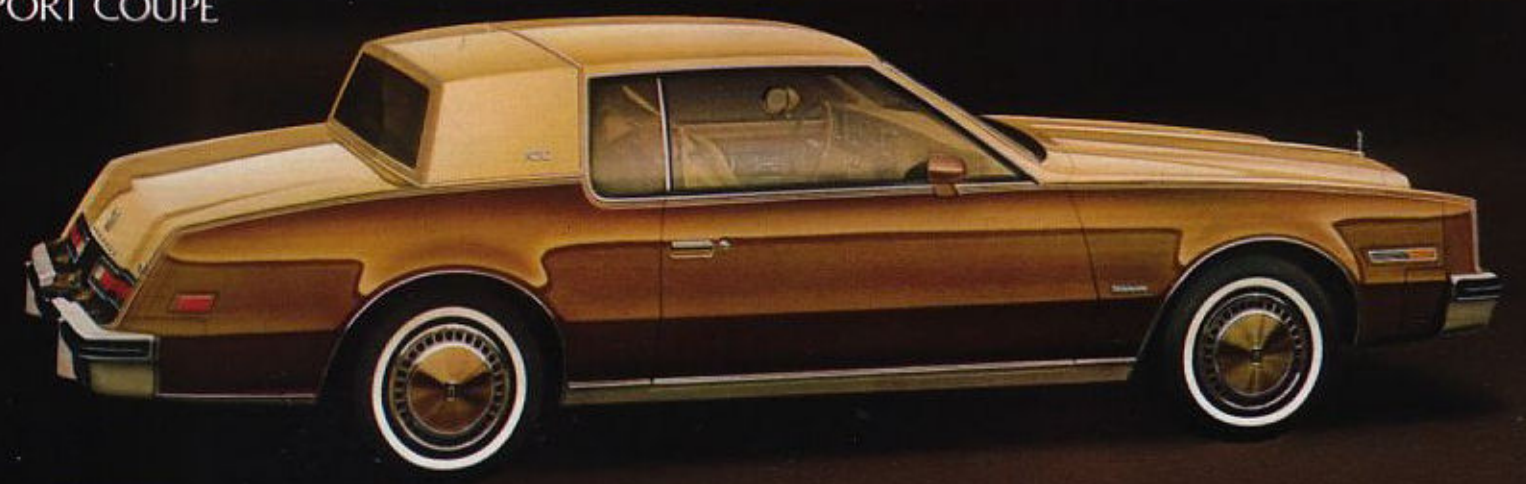

**Toronado XSC: Sophisticated. Sporty. Bucket-seated. But definitely Toronado.** Introducing a new special version of Toronado with XSC touches outside, and a very special XSC interior all its own — as you'll see on the next page.



## Toronado facts, figures and options.†

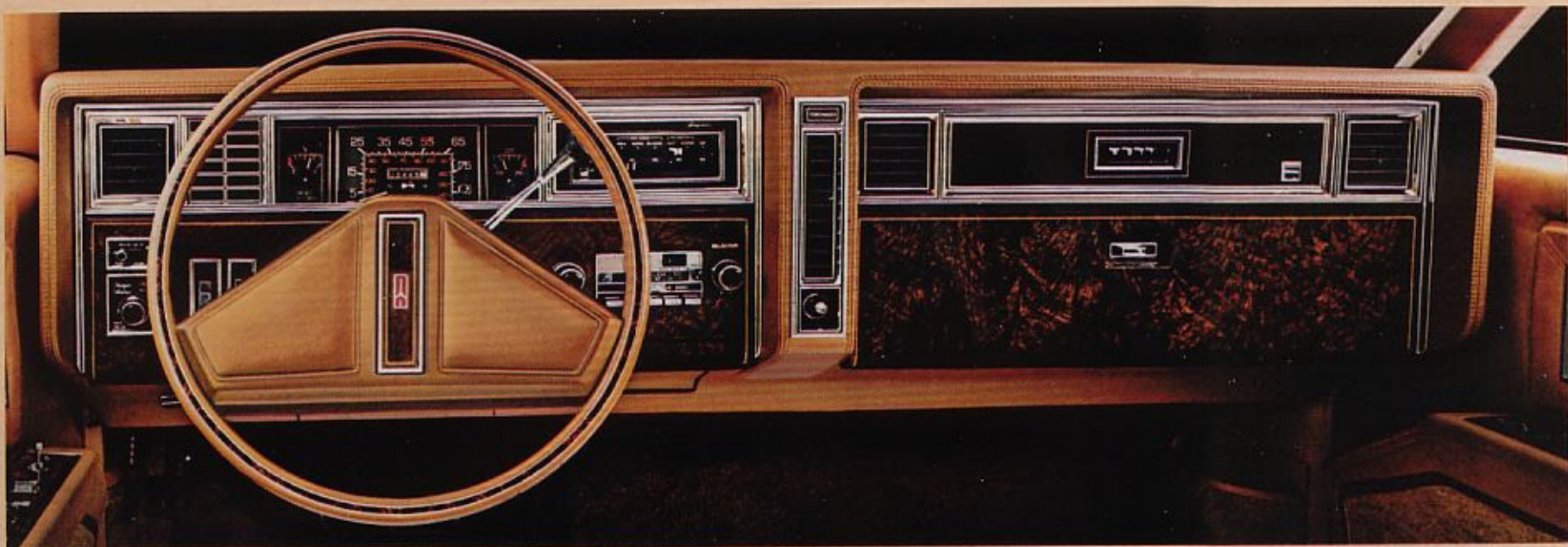

Toronado's control center includes a dazzling array of standard equipment from temperature gage to digital clock — see list, next page.



Toronado XSC provides leather-covered sport wheel, ammeter and oil gages.



Electric sunroof is available in metal or tinted glass (reduces headroom slightly).



Toronado XSC has special bucket seats and console, shown here in Dark Brown. Leather inserts also available in Black, Camel or Dark Claret interiors.



The Toronado Brougham interior available with soft leather in the seating areas, for the comfort of Toronado and the spice of leather. Shown in Camel Tan.



Over 15 cubic feet of trunk space, neatly lined, carpeted and color coordinated.

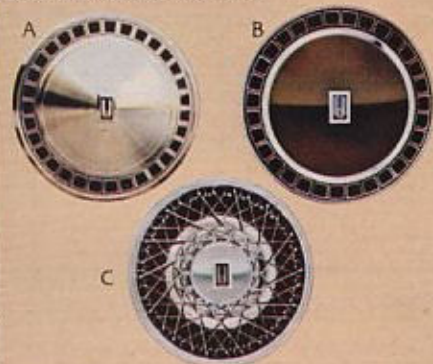

Toronado wheel discs. (A) Standard. (B) Deluxe with matching body color, XSC only. (C) simulated wire discs, available.



## TORONADO STANDARD EQUIPMENT:

### Chassis and Body:

■ Electronic high-energy ignition system  
 ■ Power brakes with front discs ■ Power steering ■ Front torsion bar and rear coil spring suspension ■ Full torque-beam frame construction ■ Compact spare tire and wheel ■ New side-frame jacking system ■ Space-efficient trunk ■ Bumper impact strips plus guards, front and rear with inserts ■ Extensive anti-corrosion treatments and sound deadeners ■ Automatic level control system ■ Tungsten halogen headlamps, high beams ■ Maintenance-free battery ■ Four-wheel independent suspension ■ Full wheel discs

### Interior:

■ Divided bench front seat with individual controls ■ Power 6-way seat adjuster, driver side ■ Full-foam cushions throughout ■ Power side windows ■ Automatic side window defoggers ■ Four-Season air conditioner ■ Front armrests with power controls ■ Cigar lighter, instrument panel ■ Electric digital clock ■ Power door locks ■ Deluxe luggage compartment trim and spare tire cover ■ Cut-pile carpeting wall-to-wall and lower door panels ■ Interior-operated hood lock release ■ Instrument panel temperature and trip odometer gages ■ Simulated Butterfly Walnut-grain instrument panel trim ■ Litter container ■ Remote control outside rearview mirrors, driver and passenger sides ■ AM-FM stereo radio, power antenna, 2 rear speakers ■ Deluxe

seat belts, all passenger positions ■ Soft-ray tinted glass ■ Deluxe steering wheel

### ADDITIONAL STANDARD EQUIPMENT:

■ Engine, 5.0-liter (307 CID) V8, 4-barrel  
 ■ Transmission, 3-speed fully automatic  
 ■ Tires, P205/75R15 steel-belted radial-ply white-stripe ■ Moldings: bright roof drip, rocker panel, wheel-opening, belt reveal

### TORONADO XSC STANDARD EQUIPMENT:

■ Contour bucket front seats ■ Sports console (shifter on column) ■ Leather-wrapped custom sport steering wheel ■ Instrument panel gages ■ Ride and handling suspension package ■ Tires, GR70-15 steel-belted radial-ply white-stripe ■ Painted wheel discs ■ Dual remote-control sports mirrors ■ Accent stripe ■ XSC emblems

### AVAILABLE TORONADO CUSTOM BROUGHAM EQUIPMENT:

- Powertrains, see below
- 6-way power bench seat
- Reclining seat back, passenger side, manual
- Reclining seat back, driver side, manual
- Power trunk-lid lock release
- Auxiliary floor mats, front and rear with carpet inserts
- Luggage compartment floor mat
- Body side molding, color-keyed to body
- Bright door-edge guard moldings
- Electric sliding sunroof, metal or tinted glass panel
- Full vinyl padded rooftop covering

- Pulse wiper system
- Landau rooftop covering, padded vinyl
- Electric rear window defogger
- Tempmatic air conditioner
- Exterior sail panel opera lamps
- Combination dome and dual-lens reading lamp
- Illumination package, front door locks and interior
- Outside rearview mirrors, electrically operated driver and passenger sides
- Illuminated visor vanity mirror, passenger side
- Outside rearview mirror, remote control with illuminated thermometer, driver side
- Body side accent stripe
- Power disc brakes, rear
- Engine block heater
- Automatic Cruise Control
- Tilt-Away steering wheel
- Tilt-and-Telescope steering wheel
- Simulated wire wheel disc
- Simulated wire wheel disc with lock
- Twilight sentinel
- High-capacity battery
- Theft-deterrent system
- Digital fluorescent clock
- AM-FM stereo radio with stereo tape player and 2 rear speakers
- AM-FM electronically tuned stereo radio, electronic digital display clock, 40-channel CB, power antenna, 2 rear speakers
- AM-FM electronically tuned stereo radio with electronic digital display clock, stereo tape player and 2 rear speakers

- AM-FM electronically tuned stereo radio, electronic digital display clock, 40-channel CB, stereo tape player, automatic power antenna, 2 rear speakers
- AM-FM electronically tuned stereo radio, electronic digital display clock, cassette tape player, 2 rear speakers
- AM-FM electronically tuned stereo radio, electronic digital display clock, 2 rear speakers
- AM-FM stereo radio with cassette tape player and 2 rear speakers
- AM-FM electronically tuned stereo radio, electronic digital display clock, cassette tape player, 40-channel CB, automatic power antenna, 2 rear speakers
- AM-FM stereo radio, 40-channel CB, automatic power antenna, 2 rear speakers
- AM-FM stereo radio with 40-channel CB, automatic power antenna, 2 rear speakers
- Instrument cluster gages
- Exterior lamp monitor, front and rear
- Special Firemist exterior paint
- Custom leather trim
- Convenience group, lamps and mirrors
- Reminder package, indicators
- Special lower body paint scheme
- XSC Package

### AVAILABLE SPECIAL USE EQUIPMENT:

- Heavy-duty suspension package
- High-capacity Delcotron
- Trailer electrical wiring harnesses, 5- and 7-wire
- High-capacity engine cooling system

## Toronado: Our state of the art in personal luxury cars.

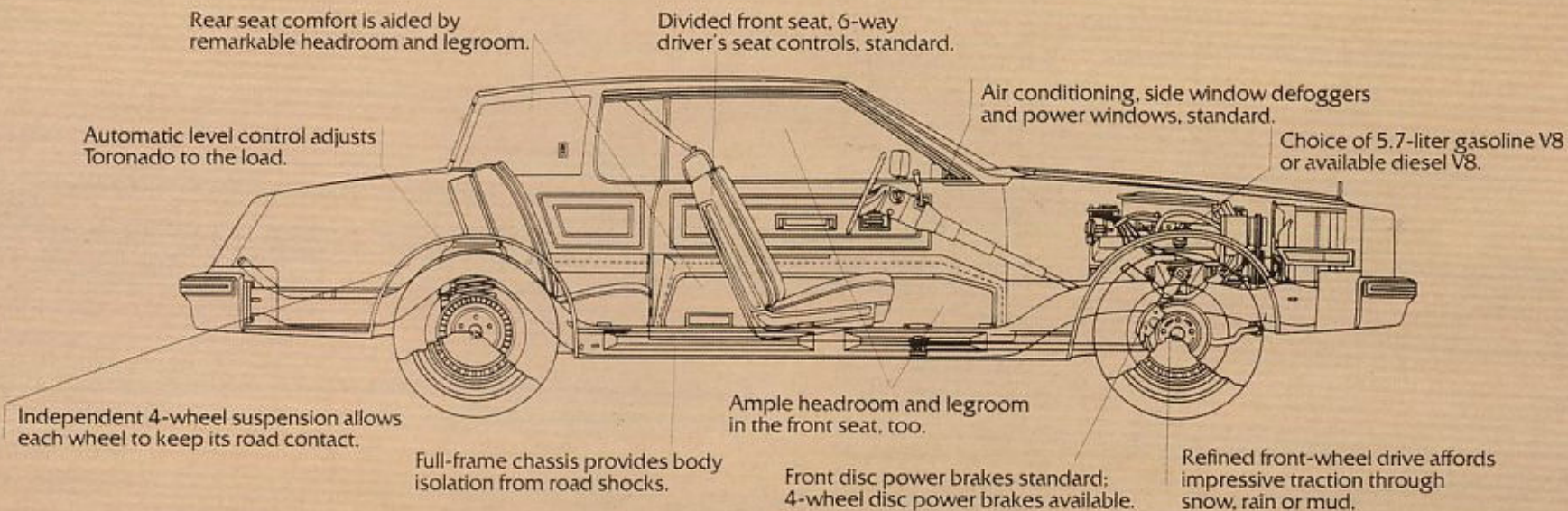

### POWER TRAINS<sup>1</sup>

Standard engine:	
■ Liter/CID/Type	5.0/307/V8
Carb./Std. axle ratio	4-bbl/2.41
Available engines:	
□ Liter/CID/Type	5.7/350/V8
Carb./Std. axle ratio	4-bbl/2.41
□ Liter/Type	5.7/diesel V8

Std. axle ratio	2.41
Standard transmission	Automatic
Fuel tank capacity (gal.)	
Gasoline	21.0
Diesel	23.0
<b>DIMENSIONS</b>	
Length (in.)	205.6

Width (in.)	71.4
Height (in.)	53.5
Wheelbase (in.)	114.0
Tread—front (in.)	59.3
rear (in.)	60.0
Wheel size—std. (in.)	15 x 6
Tire size—std.	P205/75R15
Curb weight (lbs.)	3745

### INTERIOR DIMENSIONS

Front:	
Legroom (in.)	42.8
Headroom (in.)	*37.9
Shoulder room (in.)	56.6
Rear:	
Legroom (in.)	38.9
Headroom (in.)	*37.9

Shoulder room (in.)	55.9
Trunk capacity (cu. ft.)	15.2

<sup>1</sup>Check your Engine Supplement Sheet for details; standard and available equipment may differ in California. Additional copies at your Oldsmobile dealer's.

\*Reduced slightly with sliding sunroof.



## Personal touches you can add to the Olds that's built for you.†



New Delco ETR Radios: Six new-generation electronically tuned receivers available in Ninety-Eight and Toronado models: AM/FM stereo, AM/FM stereo/8-track, AM/FM stereo/cassette, and CB/AM/FM stereo/cassette. Ask your dealer for details.



CB/AM/FM Stereo Radio: All in a single tuning unit. CB mike hangs below panel. Hear CB on 4 speakers... listen to your favorite AM or FM station and still hear CB messages. Other Delco AM, AM/FM radios to choose from, too, with and without 8-track or cassette.



Pulse Wiper: Lets you set a variety of delay-interval wipes, plus regular low- and high-speed settings — the right rate for a light mist to a heavy downpour.



New Halogen High Beam Headlamps: Now Oldsmobile owners who do much of their driving at night can enjoy the convenience of these newly available lamps.

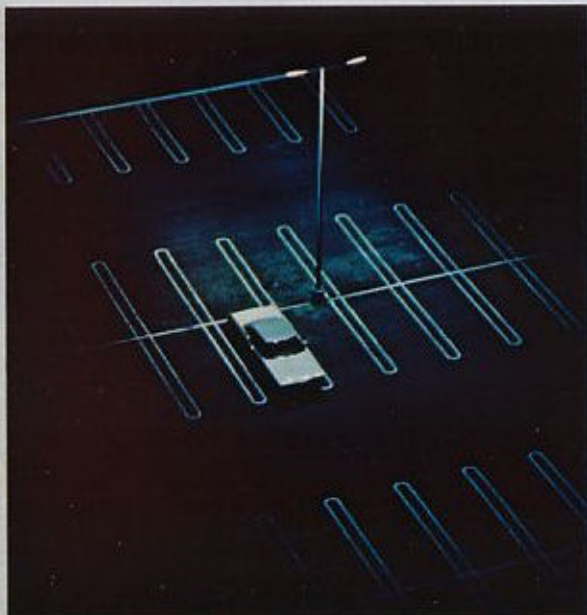

New Theft-Deterrent System: If doors or trunk are tampered with, the horn sounds, lights flash and the car cannot be started. Electric door locks option required.

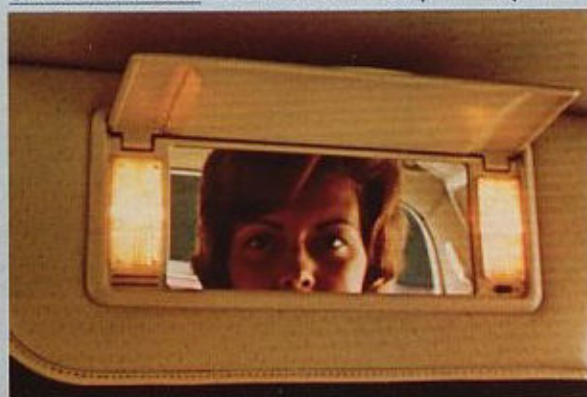

Visor Vanity Mirror: A favorite item. Lift the protective shield and dual lights shine on you as you look in the mirror. Lights go off when shield is lowered.

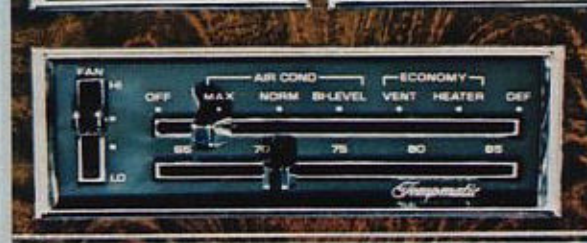

Tempmatic Air Conditioning: Just set the temperature and fan as you wish — cooled, dehumidified air, or just the right heat is yours automatically.



Illumination Package: Lift the door handle, and the "Nite Lites" go on inside and under the door handle, illuminating the keyhole. Lights stay on for 30 seconds.



Fiber Optic Lamp Monitor System (left): Monitors light on each fender and above the rear window when exterior lights, front or rear, are working.

Six-Way Power Seat Control (right): Moves the seat up or down, forward or back, tilts it forward or back to the angle that's most comfortable for you.



Cruise Control (left): Very helpful in our 55 mph world. Push this button, and you can select the speed you want to maintain; touch the brake and it's deactivated.

Dome and Reading Lamps (right): Turn on center light for the whole interior, or a personal reading light for driver or passenger. Very handy for nighttime map-reading, note-taking, toll-booth change, etc.



Cornering Lamps: Set your turn indicator when the headlamps are on, and a wide beam of light illuminates your path sideways, left or right.

**Continuous  
Protection  
Plan**

**GM**

GM's Continuous Protection Plan takes care of you and your Olds during and after new vehicle limited warranty. Coverage available in U.S.A., Canada only.



# There's an Olds that's built for you. Ahhh, but which one?

<b>TORONADO</b>  TORONADO BROUGHAM COUPE (1)	<b>DELTA 88</b>  DELTA 88 ROYALE SEDAN	<b>CUTLASS</b>  CUTLASS BROUGHAM SEDAN	<b>OMEGA</b>  OMEGA BROUGHAM COUPE
<b>NINETY-EIGHT</b>  98 REGENCY COUPE	 DELTA 88 COUPE (2)	 CUTLASS LS SEDAN	 OMEGA BROUGHAM SEDAN
 98 REGENCY SEDAN	 DELTA 88 SEDAN	 CUTLASS SEDAN	 OMEGA COUPE (5)
 98 LUXURY SEDAN	<b>CUSTOM CRUISER</b>  CUSTOM CRUISER (3)	 CUTLASS SALON BROUGHAM 2-DOOR	 OMEGA SEDAN (5)
<b>DELTA 88</b>  DELTA 88 ROYALE BROUGHAM COUPE	<b>CUTLASS</b>  CUTLASS SUPREME BROUGHAM COUPE	 CUTLASS SALON 2-DOOR	<b>STARFIRE</b>  STARFIRE SX SPORT COUPE (6)
 DELTA 88 ROYALE BROUGHAM SEDAN	 CUTLASS CALAIS COUPE (4)	<b>CUTLASS CRUISER</b>  CUTLASS CRUISER BROUGHAM (3)	 STARFIRE SPORT COUPE (7)
 DELTA 88 ROYALE COUPE	 CUTLASS SUPREME COUPE	 CUTLASS CRUISER	(1) XSC PACKAGE AVAILABLE. (2) 88 HOLIDAY PACKAGE AVAILABLE. (3) WITH AVAILABLE WOOD-GRAIN VINYL. (4) 4-4-2 PACKAGE AVAILABLE. (5) SX PACKAGE AVAILABLE. (6) GT PACKAGE AVAILABLE. (7) GT AND FIRENZA PACKAGES AVAILABLE.

1980 OLDSMOBILE  
EXTERIOR COLORS ON  
ALL MODELS



Printed colors are approximates only, and may vary from actual car paint colors





*Oldsmobile*

WE'VE HAD ONE BUILT FOR YOU