

DODGE

1974

WAGONS

MONACO · CORONET



CORONET '74.

DESIGNED WITH YOUR FAMILY  
IN MIND.

From the ground up. And from the inside out. Coronet wagons are designed for families on the go. Like your family. Within Coronet's roomy interior, you'll find ample space for most anything . . . from picnic paraphernalia to plywood paneling. A full 86.8 cubic feet of cargo space, to be exact. That's ample enough to handle four-by-eight-foot sheets of plywood lying flat—with the tailgate closed! Then there're the comfort and convenience of Coronet's rear-facing third seat. And Coronet's three-way tailgate that opens flat for loading, to the side like a door, and with the window *up* or *down* (when used as a door). Since families usually have a little tyke or two (not to mention Fido), Coronet's all-vinyl upholstery is practically soil-proof. You'll appreciate Coronet's trim outside dimensions and smooth, easy handling. And the confidence of standard power front disc brakes. Plus TorqueFlite transmission standard on three-seat models. But best of all, you'll appreciate Coronet's value. A lot of car for a surprisingly low price. Coronet '74. The ideal family wagon? Ask your family.



CORONET CRESTWOOD 3-SEAT WAGON





MONACO AND MONACO CUSTOM  
WAGONS FOR '74.  
THE SPACE VEHICLES . . . INNER SPACE.

Space. Volumes of it. Luxuriously appointed, quality-engineered. That's what people look for in a full-sized wagon. And that's what you'll find in the all-new Monaco wagons for 1974. Monaco and Monaco Custom. Both offer full-sized cargo capacity (100.8 cubic feet), and full-sized features such as TorqueFlite automatic transmission, power steering, power front disc brakes, and more . . . all standard equipment. The all-new Monaco and Monaco Custom. Whichever you choose, think of it as your personal space vehicle. NASA never had it so good.



MONACO CUSTOM 2-SEAT WAGON

# EVERYTHING YOU'VE ALWAYS WANTED AND A FEW THINGS YOU

## STANDARD EQUIPMENT

	CORONET	CRESTWOOD	MONACO	BROUGHAM
--	---------	-----------	--------	----------

INTERIOR:	CORONET	CRESTWOOD	MONACO	BROUGHAM
All-vinyl front bench seats	•	•	•	•
All-vinyl front bench seats with center armrests			•	
All-vinyl 50/50 bench seat with built-in armrests				•
Ashtrays, front and rear	•	•	•	•
Automatic transmission (Coronet 3-seat wagons)		•	•	•
Cargo compartment carpeting			•	•
Cargo compartment light				•
Cigarette lighter	•	•	•	•
Cigarette lighter courtesy light				•
Color-keyed carpeting		•	•	•
Color-keyed rubber floor mats	•			
Driver door storage compartment				•
Electric clock				•
Glove box coin changer				•
Glove box courtesy light				•
Heater/defroster	•	•	•	•
High-speed starter	•	•	•	•
Inside hood release				•
Instrument panel with wood-grained vinyl		•		•
Instrument panel, Rallye-type			•	
Map light				•
Power front disc brakes	•	•	•	•
Power steering				•
Power tailgate window				•
Rear door courtesy light switch				•
Rearview mirror, inside day/night	•	•	•	•
Rearview mirror, outside left (chrome)	•	•	•	•
3-spoke steering wheel with padded horn button	•			
Deluxe 3-spoke steering wheel with wood-grained vinyl insert		•	•	•
Upper level ventilation				•
EXTERIOR:				
Electric arm-mounted windshield washers	•	•	•	
2-speed windshield wipers	•	•	•	•
Bumper guards, rear	•	•	•	
Deluxe wheel covers			•	•
Front sway bar on standard suspension system	•	•	•	•
Horn, single	•	•	•	•
Horns, dual				•
Hubcaps	•	•	•	•
Mouldings, belt				•
Mouldings, body side		•	•	
Mouldings, body side with vinyl insert			•	•
Mouldings, drip rail		•	•	•
Mouldings, wheel-lip		•	•	•
Roof air deflector			•	•
Wood-grained vinyl body side applique			•	•
Wood-grained vinyl lower tailgate applique			•	
Wood-grained vinyl tailgate and surround moulding				•

SAFETY EQUIPMENT	
Antitheft steering column lock	Manual latches on folding front seatbacks
Backup lights	Mirror, left, outside
Breakaway front ashtray	Mirror, rearview, inside, with double-ball-joint safety mount
Combination side markers, light reflectors	Nonoverride door locks, except driver's door
Dual Braking System with warning light	Padded instrument panel and sun visors
Energy-absorbing bumper systems	Parking brake with warning light
Energy-absorbing steering column and wheel	Safety-Action inside door handles
Passenger restraint system with starter interlock	Safety-Rim wheels
Hazard Warning Light System	Side door steel guard beams
Head restraints	Turn signals with lane-change feature
"Key-left-in-ignition" warning buzzer	Windshield wipers and washers

## CORONET DIMENSIONS AND STANDARD SPECIFICATIONS

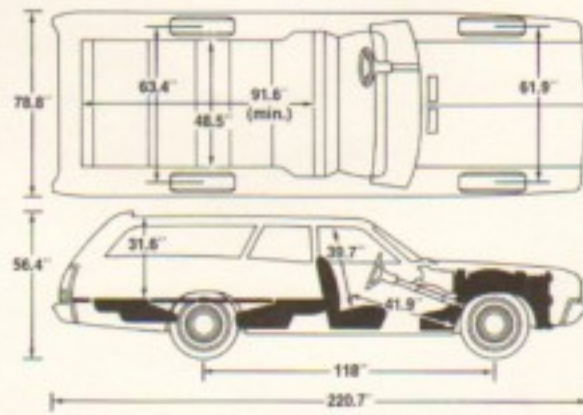

ENGINE:	318 V8
TRANSMISSION:	3-speed manual, column-mounted shift
SUSPENSION:	Front: torsion bars with sway bar Rear: asymmetrical leaf springs
TIRES & WHEELS:	H78 x 14 bias-belted BSW; 14 x 5.5 wheels
BRAKES:	Front: power disc; rear: 11" x 2 1/2" drum
AXLE RATIOS:	3-speed manual, 3.23 TorqueFlite auto., 2.94 (opt. 2.76/3.23)
ELECTRICAL SYSTEM:	Battery: 305-amp; alternator: 50-amp Electronic Ignition System Transistorized voltage regulator
FUEL TANK:	21 gallons
CARGO CAPACITY:	86.8 cu. ft.

## MONACO DIMENSIONS AND STANDARD SPECIFICATIONS

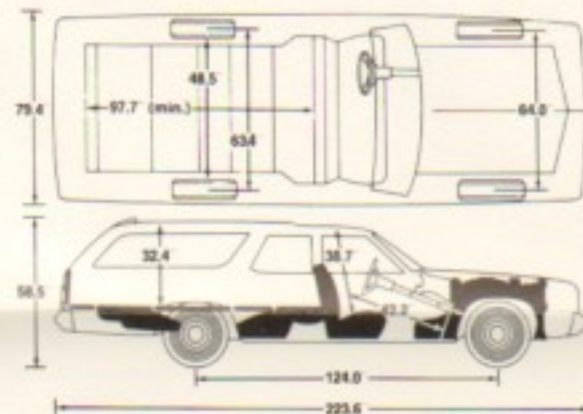

ENGINE:	400 V8
TRANSMISSION:	TorqueFlite 3-speed automatic
SUSPENSION:	Front: torsion bars with sway bar Rear: asymmetrical leaf springs
TIRES:	J78 x 15 bias-belted BSW (Monaco and Monaco Custom 2-seat) JR78 x 15 steel-belted WSW radial (Brougham 2-seat) LR78 x 15 bias-belted BSW (Monaco Custom 3-seat) LR78 x 15 steel-belted WSW radial (Brougham 3-seat)
WHEELS:	15 x 6.5
BRAKES:	Front: power disc; rear: 11" x 2 1/2" drum
AXLE RATIOS:	2.71 (opt. 3.23)
ELECTRICAL SYSTEM:	Battery: 375-amp; alternator: 50-amp Electronic Ignition System Transistorized voltage regulator
FUEL TANK:	24 gallons
CARGO CAP.:	100.8 cu. ft.

## SPORTSMAN DIMENSIONS\* AND STANDARD SPECIFICATIONS

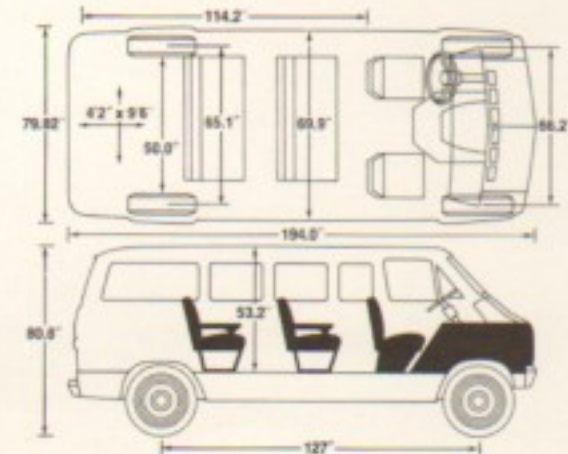

ENGINES:	225 Six, 318 V8
TRANSMISSION:	3-speed manual
SUSPENSION:	Front: coil springs; rear: leaf springs
TIRES:	G78 x 15-B
WHEELS:	15 x 5.5
BRAKES:	Front: power disc; rear: 11" x 2 1/2" drum
AXLE RATIOS:	3.55:1 (std. Six), 3.23:1 (std. V8)
ELECTRICAL SYSTEM:	Battery: (48-amp-hr) Alternator: 41-amp Transistorized voltage regulator
FUEL TANK:	23 gallons

\*1920 Sportsman dimensions based on 127" wheelbase. Sportsman is also available in a 109" wheelbase and a 127" wheelbase Maxiwagon.



Coronet Crestwood's standard interior.



A 4' x 8' sheet of plywood illustrates the generous cargo capacity on all Dodge wagons.



Convenient hideaway storage compartment in driver's door—standard on Monaco wagons.



The look and feel of luxury. Monaco Custom.



## ROYAL SPORTSMAN.

The 1974 Sportsman wagon. For versatility, comfort, and convenience, it's hard to beat the new Dodge Sportsman... because Sportsman represents a new approach in wagons. And it's catching on fast for uses in business, as a second car, as a recreational vehicle, and more. Ask your Dodge Dealer for a Sportsman catalog for more information.

TO KNOW ABOUT DODGE WAGONS.  
YOU NEVER EXPECTED.

OPTIONAL EQUIPMENT

CORONET  
CORONET CUSTOM  
CRESTWOOD  
MONACO  
MONACO CUSTOM  
BROUGHAM



vinyl Bancroft seat with fold-down center armrest.

400 4-bbl. V8 engine	•	•	•	•	•	•
440 4-bbl. V8 engine					•	•
Air conditioning	•	•	•			
Air conditioning with automatic temperature control				•	•	•
All-vinyl front bench seat with center armrests						•
Automatic speed control • Tailgate Auto-Lock	•	•	•	•	•	•
Bumper guards, front and rear (rear bumper guards standard on all Coronet wagons)	•	•	•	•	•	•
Cargo compartment carpeting and storage lock (storage lock N/A on Coronets)	•	•	•	•	•	•
Door-edge protector mouldings • Engine block heater					•	•
Electric clock (standard on Brougham)	•	•	•	•	•	•
Electronic digital clock • Rear step pads • Passenger assist handles					•	•
Heavy-duty shock absorbers	•	•	•	•	•	•
Inside hood release	•	•	•			
Protective rubber floor mats • Roof luggage rack • Sure Grip differential	•	•	•	•	•	•
Power door locks • Power front seat						•
Power steering and power tailgate window (both standard on all Monaco wagons)	•	•	•	•	•	•
Power windows • Tinted glass (all windows) • 3-speed windshield wipers	•	•	•	•	•	•
Outside right manual mirror	•	•	•			
Outside left remote-control rearview mirror	•	•	•	•	•	•
Outside right remote-control rearview mirror					•	•
Music Master AM radio • AM/FM monaural radio • AM/FM multiplex stereo radio	•	•	•	•	•	•
AM radio with stereo 8 track • AM/FM multiplex stereo radio with 8 track					•	•
Single rear seat speaker (standard with stereo on Coronets)					•	•
Dual rear seat speakers (standard with stereo)					•	•
Roof air deflector (standard on all but Coronet and Coronet Custom)	•	•				
Security Alarm System (power door and tailgate locks required)					•	•
"Tuff" steering wheel (power steering required)	•	•	•			
Tilt and telescope "Rim Blow" steering wheel					•	•
TorqueFlite 3-speed automatic transmission (standard on all Monaco wagons)	•	•	•			
Vent windows (with tinted glass only) • Undercoating and hood insulator pad					•	•
Upper level ventilation (standard on all Monaco wagons without A/C)	•	•	•			
Premier wheel covers					•	•
Rallye road wheels with chrome trim rings	•	•	•			
Chrome-styled road wheels with chrome trim rings • Wire wheel covers	•	•	•			
Deluxe wheel covers	•	•	•	•	•	•

OPTIONAL PACKAGES

**CORONET LIGHT PACKAGE** • Fender-mounted turn signal indicators • Map and courtesy light • Ashtray and glove box lights • Cargo compartment light • Rear door dome light switch • "Headlight-on" warning buzzer • Ignition switch light with time delay.

**MONACO LIGHT PACKAGE** • Fender-mounted turn signal indicators • Front seat courtesy lights • Ignition switch light with time delay • "Low-fuel" warning light-emitting diode • "Door ajar" warning light • Cargo compartment light • Glove box light (standard on Monaco Custom and Brougham) • Map light, cigarette lighter light, and rear door light switch (standard on Brougham) • Headlight switch light with time delay • Battery condition warning light-emitting diode.

**CORONET E-Z ORDER PACKAGE** (available on Coronet Custom and Crestwood only) • Automatic transmission • Power steering • AM radio • Outside left remote-control mirror • Deluxe wheel covers (standard on Crestwood) • Inside hood release • Coronet Light Package • 3-speed windshield wipers • Bumper guards • Undercoating and hood insulator pad • Whitewall tires • Roof luggage rack.

**MONACO E-Z ORDER PACKAGE** (available on Monaco Custom and Brougham only) • Roof luggage rack • AM radio • Rear seat speaker • Deluxe bumper guards • Whitewall tires (std. Brougham) • Deluxe wheel covers (Custom) or Premier wheel covers (Brougham) • Electric clock (Custom) • Electronic digital clock (Brougham) • Monaco Light Package • Outside left remote-control mirror • 3-speed windshield wipers • Undercoating and hood insulator pad.

**CORONET LUXURY EQUIPMENT PACKAGE** (available on Coronet Custom and Crestwood only) • Air conditioning • Tinted glass • Electric clock • Vinyl body side mouldings (standard on Crestwood) • Power tailgate window • Power windows • AM/FM radio • Rear seat speaker • Auto speed control • Auto-Lock tailgate • Upper door mouldings • Deluxe steering wheel • Cargo compartment carpeting (std. Crestwood) • Roof air deflector • Plus additional equipment listed in the Coronet E-Z Order Package.

**MONACO LUXURY EQUIPMENT PACKAGE** (available on Custom and Brougham only) • Electronic digital clock • Air conditioning • Tinted glass • AM/FM radio • Power windows • Power seat • Power door locks • Tailgate Auto-Lock • Outside left and right remote-control mirrors • Premier wheel covers • Deluxe steering wheel • Automatic speed control • Assist handles • Cargo compartment carpeting and storage lock (std. Brougham) • Plus additional equipment listed on the Monaco E-Z Order Package.

**TRAILER-TOWING PACKAGES** • See back cover.



Handy storage compartments for miscellaneous items.



Tailgate Auto-Lock secures tailgate automatically as you turn the ignition key.



Electronic Ignition for 36% more starting voltage.



The Dodge three-way tailgate can open like a door, with the window up or down.



New roof-mounted air deflector standard on all Monaco wagons.



Vent windows—optional on Monaco wagons.



aco Brougham's standard all-vinyl 50/50 seat with individual fold-down armrests.

EXTRA CARE IN ENGINEERING MAKES A DIFFERENCE IN DODGE . . . DEPEND ON IT!

There are important engineering differences in every Dodge car made in this country. Differences that are basic to the way we build our cars. Differences that could help you choose your next car.

**ELECTRONIC ENGINE TESTING**—Every one of our engine plants in this country has Electronic Engine Function Testers to help keep substandard engines out of your car. These testers check the engines for correct exhaust pressure pulses—one of the keys to a smooth-running, dependable engine.

**USE OF ELECTRONICS**—Dodge offers such Space Age electronic advancements as Electronic Ignition, silicon electronic voltage regulator, optional electronic digital clock, and our factory-installed optional Electronic Security Alarm System.

**TORQUEFLITE TRANSMISSION**—Standard on all full-sized Dodge cars. Rugged and dependable. With no recommended fluid replacement, filter replacement, or band adjustment under normal driving conditions.

**ELECTRONIC IGNITION**—Standard on every Dodge built in the U.S.A., our proven Electronic Ignition System delivers up to 36 percent more starting voltage than conventional systems to help you start in any kind of weather.

**TORSION-BAR SUSPENSION**—Standard on all Dodge cars made in the U.S.A., our torsion-bar front suspension is more easily adjusted for height than conventional coil springs.

**UNIBODY CONSTRUCTION**—The body panels and structural members on all Dodges are fused into one unit by more than 4,000 tough welds for strength and durability.







## MONACO BROUGHAM '74.

### HOW TO CARRY IT OFF WITH CLASS.

The all-new Monaco Brougham wagon for 1974. Like all three Monacos this year—Monaco Brougham, Monaco Custom, and Monaco—it's the result of extensive consumer research. Monaco Brougham. The full-sized wagon with a lot more than just loadspace. The "more" we're talking about is luxury. The luxury you'll feel in Monaco Brougham's all-vinyl 50/50 seat with passenger recliner. And the luxury you'll see, thanks to the

Brougham's generously appointed trim and wood-grained vinyl appliques. This wagon also offers a host of convenience features. Things like a center-mounted glove compartment that eliminates the driver's dilemma of "glove box stretch." And a handy built-in coin holder. Plus a new rear window air deflector and driver door storage compartment . . . all standard equipment.

Monaco Brougham also features an improved ride with refined torsion-bar suspension. And for the first time, you can order a factory-engineered trailer-towing package complete with hitch platform. So if you're big on wagons, we think you've met your match. Meet Monaco Brougham.

MONACO BROUGHAM 3-SEAT WAGON

## 1974 DODGE WAGON SELECTOR



MONACO 4-DOOR WAGON



MONACO CUSTOM 4-DOOR WAGON



CORONET 4-DOOR WAGON



MONACO BROUGHAM 4-DOOR WAGON



CORONET CUSTOM 4-DOOR WAGON



CORONET CRESTWOOD 4-DOOR WAGON

### COMPLETE TRAILER-TOWING PACKAGES

Now you can order your new Dodge wagon factory-engineered for trailering. We're offering the most complete trailer-towing packages in Dodge history. Now you can drive out of your Dealer's showroom ready to tow up to 7,000 pounds\* total trailer weight! Depending on what you plan to tow, choose either the light, heavy, or RV7 packages. All offer heavy-duty suspension, wide wheels, built-in seven wire trailer wiring harness and seven pin A.T.A. connector, and variable-load turn signal flasher. The light trailer-towing package offers a load-carrying trailer hitch for loads up to 2,000 pounds total trailer weight. The heavy package features a 7,000-pound-capacity load-distributing hitch platform plus the following additional equipment:

- Maximum cooling system
- Auxiliary transmission oil cooler
- 3.23 to 1 ratio rear axle
- Trailer electric brake controller
- 65-amp alternator
- High-amp battery
- Dual battery charging unit.

The RV7 package (N.A. Coronets) offers all the above plus a 440 four-bbl. V8 engine\*\* and special oil pressure and coolant temperature gauges. Whatever you plan to tow, from trail bikes to travel trailers, Dodge comes ready to tow . . . and go. Depend on it!

**ADDITIONAL REQUIRED EQUIPMENT:** For safe, efficient trailer-towing operation, an automatic transmission, power front disc brakes, and larger tire sizes are required equipment with some Dodge trailer-towing packages. These options are not included in the preceding listings due to the fact that automatic transmission and power front disc brakes are standard on all Monacos, and power front disc brakes and larger tire sizes are standard on all Coronet wagons. Consult your Dodge Dealer for the tire sizes required on other Dodge models.

\*Monaco maximum capacity. Coronet maximum capacity—5,000 lbs.  
\*\*40 4-bbl. V8 engine N.A. on Coronets sold in California.



### EXTERIOR COLORS



†Monaco only.

NOTE: Due to occasional printing irregularities, the above colors may vary slightly from actual hues. See your Dodge Dealer for accurate color chips.

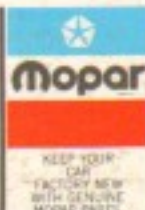

All product illustrations and specifications are based on authorized information. Although all descriptions are believed correct at publication approval, accuracy cannot be guaranteed. Some of the equipment shown on product illustrations is optional at extra cost. Dodge Division reserves the right to make changes from time to time, without notice or obligation, in prices, specifications, colors and materials, and to change or discontinue models.

FORM NO. 81-006-0034

LITHO IN U.S.A. 8/73

