

# PLYMOUTH RELIANT



THE 5/50 RELIANT. MATCH IT. IF YOU CAN.

1984

## RELIANT SE WAGON

The Ultimate Reliant Wagon.

The Reliant Special Edition station wagon represents the highest form of Reliant wagon style, convenience and comfort. Reliant gives you clean, contemporary good looks, front-wheel drive, six-passenger roominess, and Chrysler's engineered-in quality for smooth ride and handling. Unmistakable is the classic look created by simulated woodgrain body-side and liftgate applique with simulated woodgrain surround moldings. (Shown below: the Reliant SE wagon in Beige Crystal Coat with simulated woodgrain applique and equipped with wire wheel covers, wide white sidewall tires and optional luggage rack.) Bright moldings add a special touch to the windshield, upper and lower door frames, and quarter windows. Standard appearance features include new right and left remote controlled chrome mirrors, deluxe wheel covers, and wraparound taillamps. There's the extra convenience of standard rack-and-pinion power steering, while special sound insulation helps to keep things quiet...and enhance your overall driving pleasure.



## RELIANT SE TWO-DOOR SEDAN

The Personal Side of Sensible.

The Reliant Special Edition two-door sedan always says something very special about you. (Reliant SE two door sedan, shown in Garnet Red Pearl Coat with 14-inch optional aluminum road wheels and white sidewall tires.) The *Special Edition* plaque on the rear roof pillar makes this clear from the start. Quarter window louvers, along with bright trim moldings on the decklid, backlight, windshield, upper door frames, belt and taillamp, add to its already impressive appearance. Lighting for both the glove box and trunk lends a personal touch of convenience. Special Edition seats with center armrest, woodtone instrument panel, electronically tuned AM radio, digital display clock, and luxury steering wheel are all standard, or you can choose available bucket seats with a convenient center console to meet your personal standard of Reliant value.





## RELIANT SE FOUR-DOOR SEDAN

Value Fashioned With Distinction.

It's rare today to find a combination of practicality, comfort and efficiency with this kind of stylish touch. The Reliant Special Edition four-door sedan does so beautifully. Special Edition cloth-trim bench seats with center armrest are coordinated with Special Edition door trim panels. Other standard interior features include an electronically tuned AM radio with digital clock, upper and lower woodtone instrument panel, and a luxury two-spoke color-keyed steering wheel. The dome light lights up when any door is opened. Rear door glass louvers, along with bright moldings on the windshield, backlight, belt, upper door frame, trunk lid and taillamp, give the Reliant four-door SE a look all its own.



STEP INSIDE A WORLD OF PLENTY









## RELIANT TWO-DOOR AND FOUR-DOOR SEDANS

Value For All the Things You Are.

For 1984, Plymouth Reliant is the value leader among America's front-wheel drive, family-size sedans. Whether you prefer the two-door or four-door model, the reasons for choosing a Reliant sedan are really very simple.

First, good fuel economy. Reliant's standard 2.2-liter engine and four-speed manual transaxle contribute to the 1984 Reliant two- and four-door models' ratings of **29** EPA EST MPG; 41 estimated highway.\*

Second, smooth ride and handling ease. Rack-and-pinion steering provides a precise "feel for the road." Reliant's improved Iso-Strut front suspension teams up with a trailing arm rear suspension design to smooth rough surfaces. Power brakes are standard for sure stops.

Third, engineered-in quality. A convenient multifunction steering column lever controls windshield wipers and washer, optical horn, headlamp dimmer and turn signals. Reliant's new design woodtone instrument panel has improved lighting, gauges for fuel, temperature and voltage, and a trip odometer.

Inside hood release and optional driver side mirror remote control are within reach. Other features include a maintenance-free battery, halogen headlamps, new 14-gallon fuel tank, and a new locking glove box for added security.

Next, six-passenger roominess. Reliant's advanced front-wheel drive design offers surprising room for six people to ride in the comfort of standard custom vinyl bench seats. New cloth fabrics are also available. Other interior touches include new color-keyed seat belts, wall-to-wall carpeting, and new carpeted trunk.

Finally, there's Reliant's clean, contemporary styling. This year's Reliant includes a new brightly accented grille design with the Chrysler Pentastar. New color-keyed front and rear bumper strips enhance and protect. Deluxe wheel covers are standard, or choose optional 13-inch luxury wheel covers or Rallye road wheels.

Distinctively classy four-door or more personal two-door model? Either way, Reliant sedan says it all in contemporary sedan value. See your Chrysler-Plymouth





## RELIANT WAGON

Ideal Wagon Value Worthy of Its Family Name.

It takes much more than a carload of kids for a station wagon to earn the name Plymouth Reliant. It takes front-wheel drive performance, family-size space and durability.

You begin with Reliant basics: front-wheel drive, rack-and-pinion steering, power brakes, steel-belted radial tires, halogen headlamps, maintenance-free battery, a standard 2.2-liter engine and four-speed manual transaxle, and much more. With standard 2.2-liter engine and four-speed manual transaxle, Reliant wagon is rated at [28] EPA EST MPG; 40 estimated highway.\*

Then you consider the reasons why people need a wagon in the first place. Reasons such as seating room for six full-size passengers ... and the flexibility to fold down the rear seat instantly for 67.7 cubic feet of carpeted cargo space. Reliant's convenient wide-opening liftgate helps to make moving loads easy-in, easy-out. There's even a handy cargo light to help you see your way.

No wagon can bear the family name without the durability Chrysler engineers have carefully designed into every single Reliant we build. Extensive use of galvanized steel helps prevent corrosion. A newly designed lower body urethane coating protects even better against chips. And Unibody construction throughout helps preserve Reliant's impressive looks.

And if your wagon needs include light trailer-towing or carrying slightly heavier loads, we suggest an available heavy-duty suspension, Mitsubishi-built 2.6-liter engine, automatic transaxle, and Engine Cooling Package as optional equipment.

What else makes Reliant so special? Its front-wheel drive maneuverability just might make you forget you're driving a wagon. Plus, its trim size can help get into and out of parking spots that some ordinary family-size wagons may not.

The fact is, there's practically nothing ordinary about Reliant wagon whatsoever. You'll be proud to put your family in the wagon that carries our proud family name of extraordinary front-wheel drive cars: Plymouth Reliant.



## PLYMOUTH RELIANT IS WINNING YOU OVER

Reliant Is A Sales Leader.

Today's smart consumers won't settle for second best. They demand real value for their dollar. So, for a car to become the top seller in its class, it has to have a lot going for it. That's why Reliant has been winning over so many American car buyers.

From the beginning of the 1983 model year through April 30, 1983, Plymouth Reliant

ALL 1983 MODELS	Units Sold: 1983 Model Year Through April 30, 1983*
Plymouth Reliant 93,533	
Chevrolet Citation 78,535	
Ford Fairmont Futura 68,128	
Buick Skylark 64,893	
Oldsmobile Omega 34,253	
Pontiac Phoenix 20,991	
Mercury Zephyr 19,456	
AMC Eagle 15,311	
AMC Concord 11,874	

\*Sales figures based on Motor Vehicle Manufacturers' Association registrations.

has outsold every domestic compact on the market.

Fuel economy, front-wheel drive performance. Family-size roominess. A wide model selection. Chrysler quality and durability. It all adds up to Reliant. You've never had so many good reasons to buy a car.

### Front-Wheel Drive Technology

Reliant's advanced front-wheel drive (FWD) design pays off in a lighter, more compact, more fuel efficient vehicle than can be offered currently with rear-wheel drive.

FWD design permits the engine and power train to be teamed into a single compact unit. This eliminates the long drive shaft and reduces the old transmission "hump." The flattened floor permits improved underbody aerodynamics, and space and weight savings, resulting in improved fuel economy.

FWD design also paves the way for the engine to be mounted transversely. The result? A bigger passenger compartment without increasing the car's length.

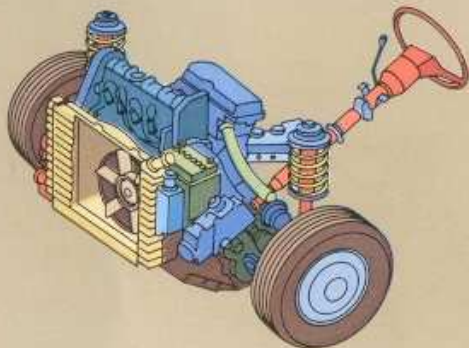

For several reasons, the basic FWD configuration provides excellent "directional stability"; the ability to stay on course. Further, by placing the engine and transaxle weight directly over the front driving wheels, traction is improved significantly on slippery surfaces.

In short, front-wheel drive adds up to an exceptional combination of fuel economy, roominess and handling called Plymouth Reliant.

### Six-Passenger Room

Equipped with its standard front bench seat, Reliant offers seating for six full-size adults. Plus there's a full 15 cubic feet of trunk space to carry everything those six folks need to bring along. It's just one more way Reliant's front-wheel drive design pays off in value for you.



## A Full Family of Family Cars



Plymouth Reliant Two-Door Sedan



Reliant SE Two-Door Sedan



Plymouth Reliant Four-Door Sedan



Reliant SE Four-Door Sedan



Plymouth Reliant Custom Wagon



## Chrysler Corporation Quality

Current research indicates buyers now rank quality and durability first when buying a car. The quality of all Chrysler-built vehicles, as measured by in-plant quality audits, improved nearly 32 percent in 1982 alone.

Chrysler Corporation enjoyed the best domestic recall record in the industry in 1982, and although final figures are not yet in, we expect to retain that leadership position for 1983.

The story of Reliant's durability starts with its standard 2.2-liter Trans-4 engine. When operated properly and maintained according to the recommended schedule, the 2.2-liter engine is designed to go 100,000 miles without mechanical problems. In fact, at this writing it has run up over 20 billion owner-driven miles in Chrysler Corporation vehicles.

It's not surprising then, that when buyers rank quality and durability first, Reliant ranks high with buyers.



## Proven Resale Value

The amount of money you pay for a new car is one measure of its value. The amount you receive when you're ready to sell reflects how well that value can be retained. Consider this: after thirty months of operation, Plymouth Reliant beat five competitive GM and Ford models in average percentage of retail value retention.

### 1981 FOUR-DOOR MODELS

NADA Average Retail  
% Of New Car  
Base Price  
(after 30 months)\*

Plymouth Reliant  
86.3%

Oldsmobile Omega  
76.5%

Pontiac Phoenix  
75.0%

Buick Skylark  
74.0%

Ford Fairmont  
72.1%

Chevrolet Citation  
71.8%

\*Percentages based on manufacturers' suggested retail introductory prices, and average retail prices published in NADA Used Car Guide, Central Edition, April 1983. Use NADA average retail prices and percentages for purposes of comparison. Actual prices may vary due to vehicle condition, mileage, optional equipment and other factors.

Resale value is based on several factors, including fuel economy, body condition and dependability. But perhaps the most important factor is the demand for a particular model in the used car market. The facts are clear: people want to own a used Plymouth Reliant as much as a new one. And that's a good thing to know before making your next new car purchase.

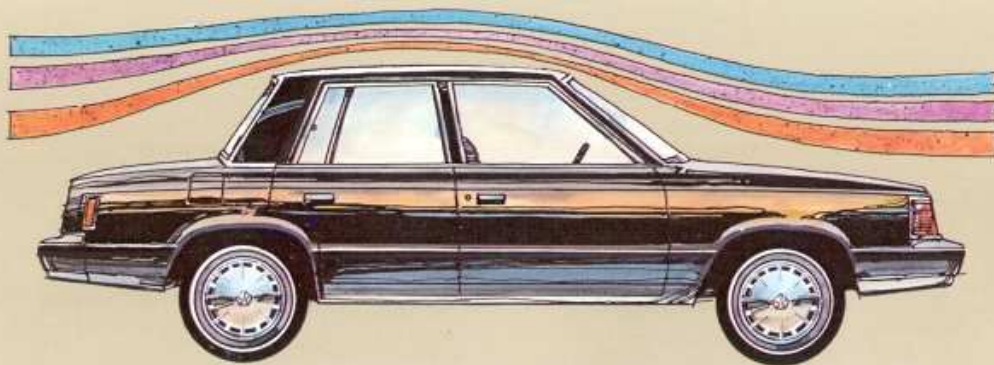

Chrysler has a longstanding reputation for excellence in engineering. As Chrysler designers and engineers have taken front-wheel technology and applied it to today's driving needs, a new generation of vehicles has been developed that offers remarkable fuel economy, driver handling, comfort and durability. Plymouth Reliant stands as an outstanding example of this engineered-in quality and value.



Proof of Chrysler's belief in the quality of its vehicles is Chrysler Corporation's Five-Year/50,000-Mile Protection Plan. Upon expiration of the normal 12-month/12,000-mile new vehicle limited warranty on 1984 Reliant, limited warranty coverage is extended on power train components,

including engine, transaxle, and axle—plus outer panel rust-through protection—to five years/50,000 miles, whichever comes first. A deductible applies. See your dealer for details.\*

High mileage has always been a Reliant strength, and 1984 is no exception. With the standard 2.2-liter engine and optional automatic transaxle, Reliant will achieve a fuel economy rating 10 percent or three miles per gallon better than at its 1981 model year introduction.

Reliant's 2.6-liter engine has been upgraded with improvements in horsepower and torque for 1984. A higher compression ratio and recalibration of the spark advance, carburetor and emission controls have resulted in an expected four percent mileage gain over that of last year's engine.

Modifications to the optional automatic transaxle (required with the 2.6-liter engine) provide increased torque capacity and greater durability. New gear ratios on the optional five-speed manual transaxle give a quicker response "feel" to the driver. And the shift effort for both four- and five-speed manual transaxles has been reduced significantly by 12 different design changes.



Chrysler engineers have also incorporated a dual proportioning valve into the brakes to provide greater bias toward the front of the vehicle during braking—a better balance for today's driving needs and load conditions.

We've also recognized your appreciation of comfort and quiet. Reliant's Iso-Strut front suspension has been redesigned to ensure that the reaction of shocks and springs is isolated and not transmitted into the vehicle. The "quiet latch" door system has been

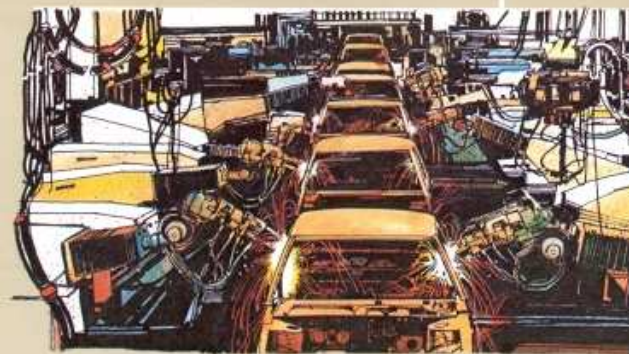

made even quieter with improved sound-deadening materials at all contact points. These steps, along with a high level of acoustical insulation throughout, should help make this the quietest riding Reliant ever.

Quality also means being able to withstand the abuse of weather, roads and time. A special urethane primer protects the lower body against chips. Underbody and underhood components receive a number of primers and treatments to prevent corrosion. And our Crystal Coat paint treatment adds an extra coat of acrylic to help resist surface abrasions and give Reliant a high-gloss appearance.

But Reliant quality doesn't end there. Thorough inspection, testing and analysis—much of it using advanced computer technology—means we check and recheck our vehicles to give you simply the best Reliant we've ever produced.

\*Fleet and lease vehicles excluded.

Front-wheel drive. Engine and transaxle drive front wheels through two short shafts. This produces excellent front-wheel traction and good directional stability.

Chrysler-built 2.2-liter Trans-4 engine. Mounted transversely, this advanced overhead cam engine design provides high performance and fuel efficiency.

Electronic feedback carburetor. Oxygen sensor monitors combustion gases to maintain ideal carburetor fuel-air mixture for best combustion efficiency. (Also available on 2.6-liter engine.)

Rack-and-pinion steering. Provides positive responsive steering with low turning effort, good returnability, and excellent directional stability.

Energy-absorbing bumper system. Reduces minor impact damage, and features protective rub strips in front and rear.

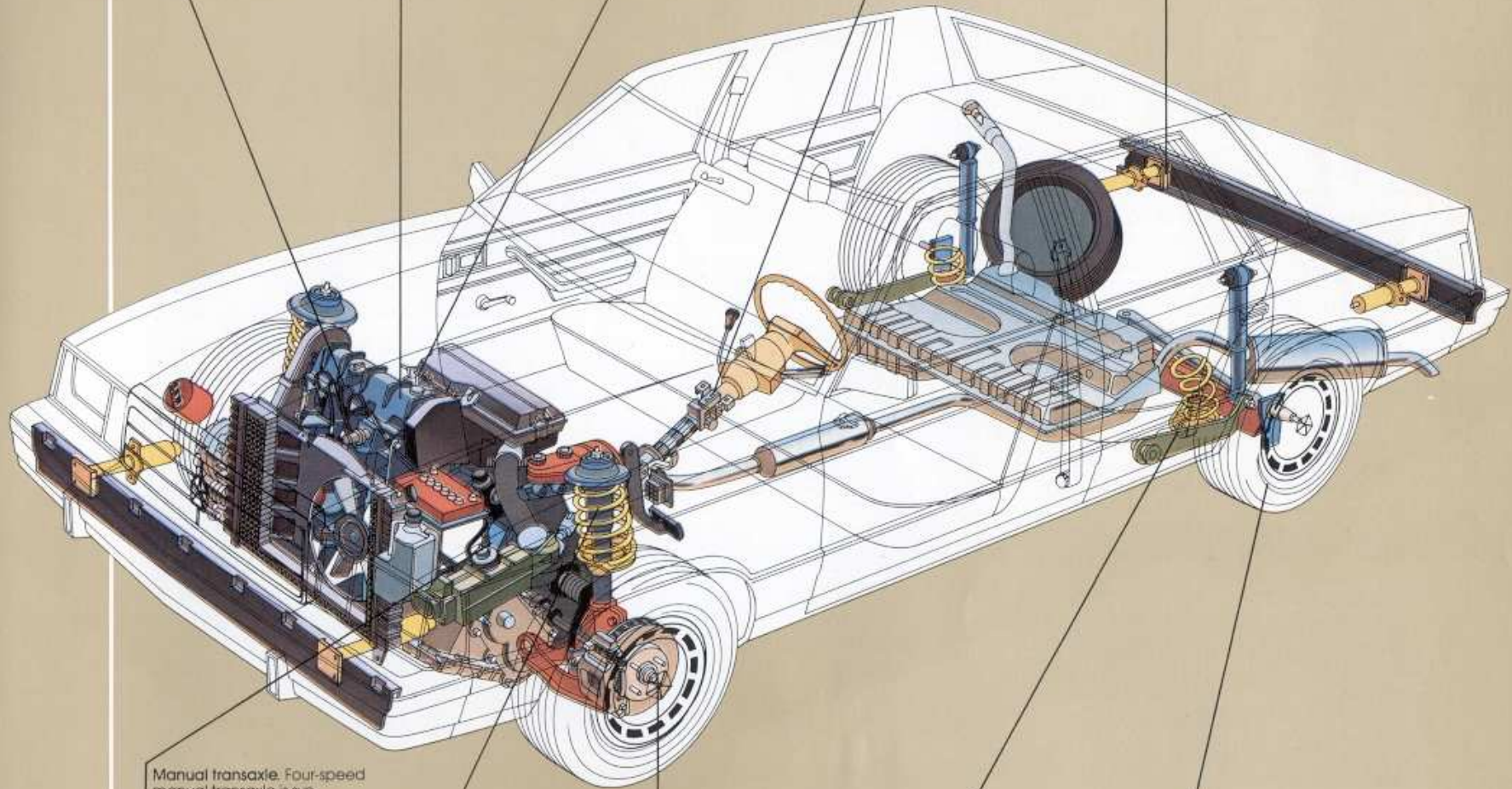

Manual transaxle. Four-speed manual transaxle is synchronized in all forward gears for smooth shifting. Fourth gear overdrive ratio for fuel economy.

Chrysler-built TorqueFlite automatic transaxle. Features wide-ratio gears, with high-ratio first and second gears for good acceleration. Three major modifications provide increased torque capacity and durability.

Iso-Strut front suspension. Independent coil spring and strut suspension with integral linkless antisway bar helps keep sound and vibration isolated from Reliant's body.

Power brakes. Front disc and self-adjusting rear drum. New load-sensing proportioning valve allows system to be biased toward front-wheel braking under all load conditions.

Trailing arm rear suspension. Beam axle and trailing arm suspension system with coil springs, shock absorbers, track bar, and torsion tube anti-roll control.

All-season radial tires. Steel-belted radial design provides road-gripping response and durability in all driving conditions.

Here are a few of the many options available at extra cost on the 1984 Reliant. You'll find more listed on the opposite page. See your Chrysler-Plymouth dealer for the most current facts on pricing and availability.

**1. Wagon Luggage Rack.** Carry any extra cargo with this adjustable crossrail luggage rack. You can use the dealer adapter kit to carry luggage, outdoor gear, skis, bikes, or whatever similar items you need to bring with you.

**2. Five-Speed Transaxle and Center Console.** An overdrive fifth gear helps save gas on long drives, while the center console with color-keyed woodtone accents adds a sporty look and feel. (Optional bucket seats required.)

**3. Electronically Tuned AM/FM Stereo Radio with Cassette Player/Dolby\* and new Digital Clock.** Precise solid state tuning eliminates fade and drift. New memory scan system stores ten stations at a time in both AM and FM, and reviews each station at the touch of a button. Features digital display, Dolby noise reduction,\* cassette tape player, and integral electronic digital clock.

**4. Air Conditioning with Bi-Level Ventilation.** Improved flow of cool, clean air comes by way of the bi-level ventilation system for more even temperatures and fewer cold drafts.

**5. Wagon Rear Window Defroster and Wiper/Washer.** Clear the view behind you with this practical option popular with wagon owners.

**6. Automatic Speed Control.** Conveniently placed on the standard steering column multifunction control lever, this fuel-saving feature can help make highway driving a snap. (Deluxe wipers required.)

**7. Wheel Covers and Treatments.** It's your choice from left to right: standard 13-inch deluxe wheel cover, 13-inch luxury wheel cover, 14-inch deluxe wheelcover, 13-inch Rallye road wheel, 14-inch wire wheel cover, and 14-inch cast aluminum wheel.

\*Dolby is a trademark of Dolby Laboratories.

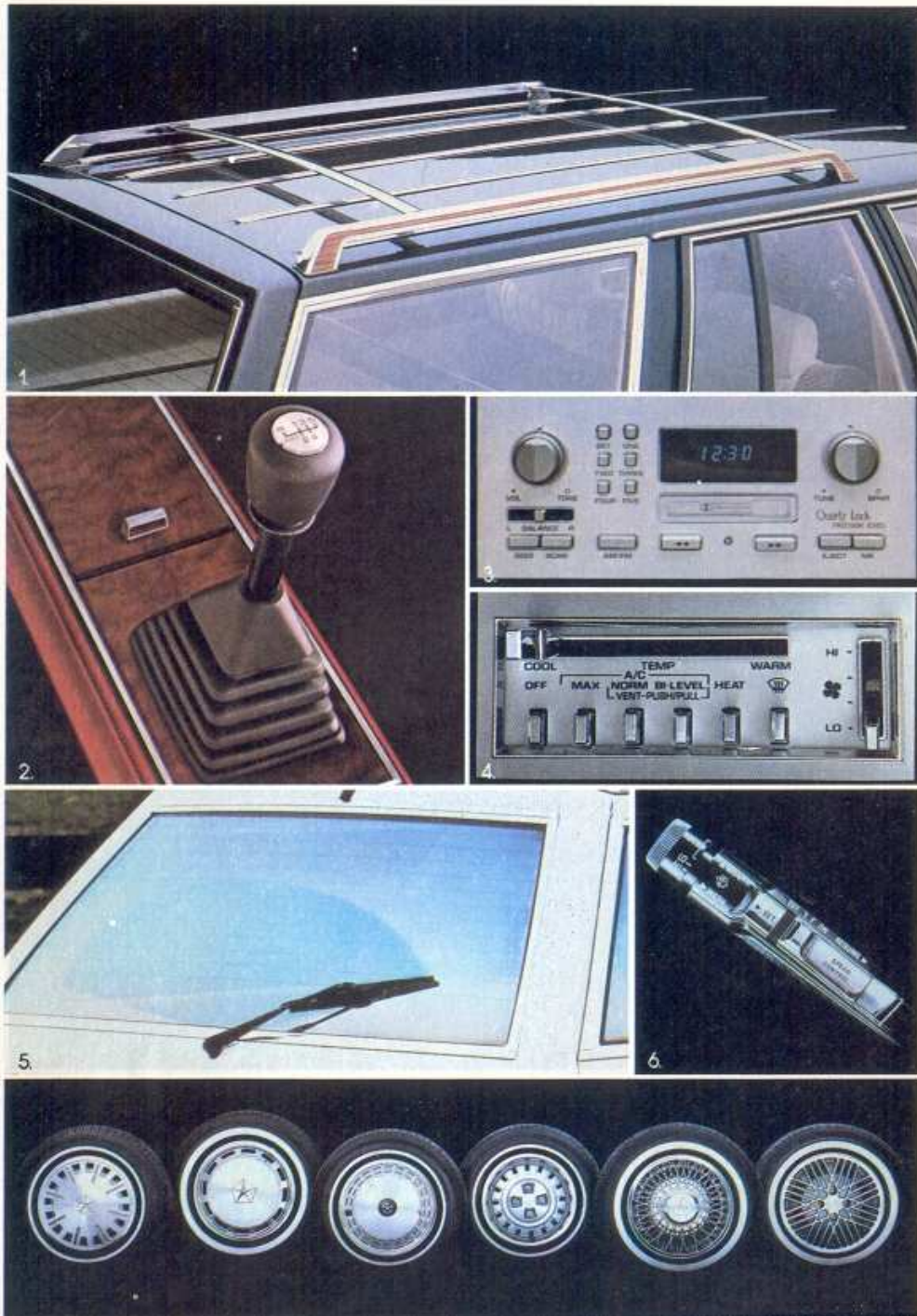



## OPTIONAL EQUIPMENT

Certain models, packages, and options are subject to specific restrictions, requirements, and late availability. Consult your dealer for current ordering information.

- Air Conditioning<sup>1,2,3</sup>—Manual bi-level
- Battery—500 amperes, maintenance-free, heavy-duty
- Bumper Guards—Front/rear
- Console—Included with bucket seats, not available otherwise
- Defroster—Rear window: electrically heated (required on sedan models registered in New York state)
- Emissions—California control and testing (required on all vehicles registered in California, not available otherwise)
- Engine—2.6-liter Mitsubishi-built<sup>4</sup> (not available on base model)
- Engine Cooling<sup>1</sup>—Recommended on vehicles to be equipped with field-installed air conditioning
- Glass—Tinted: all windows (required with air conditioning)
- Light Package—Trunk light, cargo compartment light, glove box light, ash receiver light, ignition switch with time delay light, headlights-on warning buzzer, rear dome light switches (not available on two-door), underhood light, and dome reading lamp

Mirrors—Outside left and right remote control: chrome; left remote control: chrome (std on SE wagon)

Moldings—Sill

Power

- Deck Lid/Liftgate Release<sup>5</sup>
- Door Locks<sup>6</sup>
- Seat—Bucket (left only)<sup>7</sup>
- Steering<sup>8</sup>—Rack-and-pinion (std on SE wagon)
- Windows—Front and rear<sup>6</sup>

Radios

- AM—Electrically tuned, with integral digital clock (std on Custom wagon and all SE models)
- AM/FM Premium Stereo—Electrically tuned, with Seek-and-Scan, digital display and clock: four speakers
- AM/FM Stereo—Electrically tuned, with digital display and clock: four speakers
- AM/FM Stereo—Electrically tuned, with digital display, clock, cassette player and Dolby<sup>®</sup> system: four speakers
- Radio—May be deleted for credit on factory orders, with clock also deleted.

■ Roof—Full vinyl (available on SE four-door model only)<sup>10</sup>

■ Roof—Landau: padded vinyl (available on two-door model only)

■ Sound Insulation—Special (std SE wagon)

- Spare Tire—Conventional
- Speed Control—Automatic<sup>11</sup>

Station Wagon Options

- Liftgate Washer/Wiper System
- Luggage Rack

■ Steering Column—Tilt<sup>11</sup>

■ Stripes—Accent<sup>12</sup>

■ Suspension—Heavy-duty: heavy-duty springs and shocks; larger diameter anti-sway bar on sedan (anti-sway bar standard on wagon and available on wagon only)

■ Tires—P175/BOR13 steel-belted radial white sidewall with all-season tread

■ Tires—P185/70R14 steel-belted radial white sidewall: 14-inch wheel and 14-inch deluxe wheel cover option required<sup>7</sup>

■ Transaxle—Five-speed manual (not available on base model or with 2.6-liter engine; bucket seats required)

■ Transaxle—TorqueFlite automatic wide ratio: three-speed (required with 2.6-liter engine)

■ Trunk Dress-Up—Not available on wagon or base sedan

Two-Tone Paint Package

- Body side and up-and-over roof tape stripe (one color, available on SE four-door sedan only)
- Two-color combination

■ Undercoating

Wheel Covers and Wheels

- Wheel Covers—Deluxe 14-inch: four (14" tire option required)<sup>7</sup>
- Wheel Covers—Luxury 13-inch: four
- Wheel Covers—Wire 14-inch: four (14" tire option required)<sup>7</sup>

■ Wheels—Cast aluminum 14-inch: four (14" tire option required)<sup>7</sup>

■ Wheels—Rollie 13-inch with styled centers and trim rings: four

■ Wipers—Deluxe intermittent: required with speed control and tilt steering wheel

<sup>1</sup>Vehicles without factory-installed air conditioning have special recommended cooling requirements (Engine Cooling Package) for later air conditioning installation. See your dealer for details. Tinted glass required.

<sup>2</sup>Power steering required with 2.6-liter engine.

<sup>3</sup>TorqueFlite transaxle required.

<sup>4</sup>Wagons require TorqueFlite transaxle. Light Group required on sedan.

<sup>5</sup>Dual outside remote control mirrors required.

<sup>6</sup>Not available on base model.

<sup>7</sup>Required with 2.6-liter engine and air conditioning.

<sup>8</sup>Dolby is a trademark of Dolby Laboratories.

<sup>9</sup>Not available with Two-Tone Package.

<sup>10</sup>Deluxe wipers required.

<sup>11</sup>Not available with Two-Tone Package or on SE wagon.

## INTERIOR TRIM

Standard on Reliant base model.

All-vinyl bench seat with vinyl door trim panels. Available in Medium Blue/Dark Blue, Red, Brown/Beige.



Optional on Reliant base model.

Embassy cloth bench seat with vinyl door trim panels. Offered in Silver/Charcoal, Medium Blue/Dark Blue, Red, Brown/Beige.



Standard on Reliant Custom wagon and SE models.

Cloth center armrest bench seat with cloth door trim panels. Available in Silver/Charcoal, Medium Blue/Dark Blue,\* Red, Brown/Beige.



No-charge option on Reliant Custom wagon and SE models.

Saddle vinyl center armrest bench seat with vinyl door trim panels. Available in Silver/Charcoal/Medium Blue/Dark Blue,\* Red, Brown/Beige.



Optional on Reliant Custom wagon and SE models.

Cloth-and-vinyl low-back bucket seats with dual recliners, cloth door trim panels and console. Offered in Silver/Charcoal, Medium Blue/Dark Blue,\* Red, Brown/Beige.



\*Not available on wagon model.

## STANDARD FEATURES

	Reliant	SE	Custom Wagon	SE Wagon
Alternator—60-ampere (78-amp included with rear defroster)	S	S	S	S
Armrest—Door, with integral pull handle	S	S	S	S
Ash Receivers—One front; two rear	S	S	S	S
Battery—335 amperes (maintenance-free)	S	S	S	S
Battery Test Indicator—Integral with battery	S	S	S	S
Brakes—Dual diagonal disc front, self-adjusting drum rear	S	S	S	S
Brakes—Power	S	S	S	S
Bumper Protective Felt Strips—Front and rear	S	S	S	S
Bumpers—Energy-absorbing, color-keyed	S	S	S	S
Carpeting—Cargo compartment	NA	NA	S	S
Carpeting—Passenger compartment	S	S	S	S
Cigarette Lighter	S	S	S	S
Clock—Electronic digital, standard with all radios	F	S	S	S
Clutch—Self-adjusting linkage	S	S	S	S
Coat Hooks	S	S	S	S
coolant Overflow Reservoir	S	S	S	S
Corrosion Protection—Extensive use of galvanized steel	S	S	S	S
Directional Signals—With tone-change feature	S	S	S	S
Engine—Four-cylinder 2.2-liter Trans-4	S	S	S	S
Flashers—Hazard warning	S	S	S	S
Fuel Tank—14-gallon, with curbside fuel filler and leather cap	S	S	S	S
Head Restraints—Adjustable, right and left	S	S	S	S
Headlamp Bezels—Bright	S	S	S	S
Headlamps—Halogen	S	S	S	S
Headliner—Cloth-covered	S	S	S	S
Heater and Defroster	S	S	S	S
Hood—Counterbalanced	S	S	S	S
Hood Release—Inside	S	S	S	S
Horn—Single	S	NA	NA	NA
Horns—Dual	NA	S	S	S
Instrument Panel—Color-keyed with woodtone appliques and Reliant nameplate	S	NA	NA	NA
Insulation—Hood pad	S	S	S	S
Insulation—Special Sound Package	F	F	F	F
Latches—Door, shielded to minimize freezing	S	S	S	S
Lights—Dome, backup, side marker, parking brake warning, front door activated	S	S	S	S
Lights—Dome, rear door activated (four-door only); trunk (sedan); cargo space (wagon); glove box	F	S	S	S
Lights—Warning, illigale-gate	NA	NA	S	S
Lock—Glove box	S	S	S	S
Louvers—Rear door glass, black (four-door only)	NA	S	NA	NA
Louvers—Quarter window (two-door only)	NA	S	NA	NA
Mirror—inside, day/night	S	S	S	S
Mirror—Outside, left, manual, black	S	S	S	NA
Mirror—Outside, left, remote, chrome	E	E	E	S
Mirror—Outside, right, remote, chrome	E	E	E	S
Molding—Body-side, with vinyl insert	S	S	S	NA
Molding—Deck lid, bright	NA	S	NA	NA
Molding—Drip rail, bright	S	S	S	S
Molding—Quarter window, bright (wagon)	NA	NA	S	S
Molding—Quarter window, bright and black (two-door)	S	NA	NA	NA
Molding—Quarter window, integral argent louvre, bright and black (two-door only)	NA	S	NA	NA
Molding—Tailamp	NA	S	NA	NA
Molding—Windshield, bright	S	S	S	S
Moldings—Belt and door frame, bright	NA	S	S	S
Moldings—Body-side and illigale, woodgrain applique	NA	NA	NA	S
Moldings—Liftgate, backlight, bright	S	S	S	S
Radio—AM, electronically tuned, with digital clock	E	S <sup>1</sup>	S <sup>1</sup>	S <sup>1</sup>
Restraint System—Unbelt with tension reliever and automatic release color keyed	S	S	S	S
Seat—Bench, saddle vinyl with vinyl door trim panels	S	NA	NA	NA
Seat—Center armrest bench, cloth-and-vinyl, with cloth door trim panels	NA	S	S	S
Spare Tire—Compact high-pressure	S	S	S	S
Steering—Manual, rack-and-pinion	S	S	S	NA
Steering—Power, rack-and-pinion <sup>2</sup>	E	E	E	S
Steering Column Control—Multifunction: windshield wiper/washer, headlamp dimmer, turn signals, optical horn	S	S	S	S
Steering Wheel—Deluxe, two-spoke, color-keyed	S	NA	NA	NA
Steering Wheel—Luxury, two-spoke, color-keyed	NA	S	S	S
Suspension—Front Iso-Strut with coil springs around the shock absorbers; linkless sway bar; rear flex arm beam axle with trailing links, coil springs and shock absorbers	S	S	S	S
Tailamp Accents—Bright	NA	S	S	S
Tailomps—Full width (two- and four-door sedans)	S	S	NA	NA
Tailomps—Wraparound (wagon)	NA	NA	S	S
Tires—P175/BOR13 steel-belted radial black sidewall	S	S	S	S
Transaxle—Four-speed manual <sup>3</sup>	S	S	S	S
Transaxle—Moded carpet in well/floor	S	S	NA	NA
Urethane Protective Coating—Lower body	S	S	S	S
Ventilation—Upper level forced air system with four outlets, three-mode heater with left and center Ram Air outlets	S	S	S	S
Wheel Covers—Deluxe 13-inch (set of four)	S	S	S	S
Windows—Vent rear door (four-door)	S	S	S	NA
Wiper System—two-speed, concealed, with electric washer	S	S	S	S

<sup>1</sup>Standard radio may be deleted for credit on factory orders only. S—Standard.

<sup>2</sup>Required with 2.6-liter engine option in combination with air conditioning option.

<sup>3</sup>Not available with 2.6-liter engine or bucket seat option.

NA—Not available. E—Extra cost.

## PLYMOUTH FOR 1984



HORIZON



TURISMO



GRAN FURY



VOYAGER



COLT



CONQUEST



COLT VISTA

## RELIANT EXTERIOR COLORS



Garnet Red Pearl Coat<sup>1</sup>



Crimson Red



Mink Brown Pearl Coat<sup>1</sup>

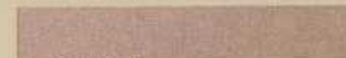

Beige Crystal Coat

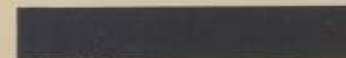

Nightwatch Blue



Glacier Blue Crystal Coat\*\*

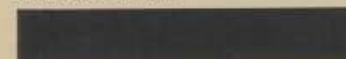

Black\*



Charcoal Crystal Coat

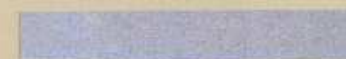

Radiant Silver Crystal Coat



White

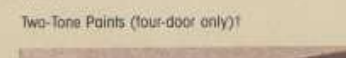

Two-Tone Paints (four-door only)<sup>1</sup>



Beige Crystal Coat/Mink Brown Pearl Coat<sup>2</sup>

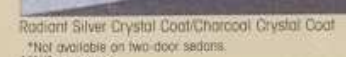

Radiant Silver Crystal Coat/Charcoal Crystal Coat

\*Not available on two-door sedans.

\*\*N/A on wagon.

<sup>1</sup>First color listed is upper body; second color is lower body.

<sup>2</sup>Pearl coat available at extra cost.

NOTE: Due to occasional printing irregularities, the colors shown may vary slightly from actual hues. See your Plymouth dealer for accurate color chips.

## CONSIDER LEASING FROM THE LEASING PROFESSIONALS

In these days of tight money and high interest rates more consumers are considering leasing as an alternative to buying. Leasing a new Plymouth Reliant usually eliminates large down payments and often results in lower

payments because you're paying only for that portion of the car life under the leasing agreement.

Leasing could be right for you, and the more you learn about it the more likely you are to consider it seriously. If leasing sounds like a sensible solution to your transportation needs, talk it over with us—your leasing professionals.

## DIMENSIONS, WEIGHT AND CAPACITY

	TWO-DOOR SEDAN	FOUR-DOOR	FOUR-DOOR WAGON
Length <sup>1</sup>	176.1"	176.1"	176.2"
Width	68.6"	68.6"	68.6"
Height	52.3"	52.7"	52.4"
Wheelbase	100.3"	100.3"	100.3"
Turning Diameter	34.8"	34.8"	34.8"
Curb Weight	2,354 lbs (Base)	2,361 lbs (Base)	2,450 lbs (Custom) 2,501 lbs (SE)
Track—front	57.6"	57.6"	57.6"
—rear	57.0"	57.0"	57.0"
Cargo Capacity	15.0 cu ft	15.0 cu ft	—
Cargo Volume Index	—	—	34.4 cu ft
—seat upright <sup>2</sup>	—	—	67.7 cu ft
—seat folded down <sup>3</sup>	—	—	—
Passenger Capacity	6	6	6
Fuel Capacity	14 gal	14 gal	14 gal

<sup>1</sup>Includes optional bumper guards.

<sup>2</sup>Environmental Protection Agency measurement.

<sup>3</sup>Motor Vehicle Manufacturers' Association measurement.

## ENGINES AND TRANSAXLES

Federal/  
California<sup>1</sup>

	2.2-Liter Engine 4-Speed Manual <sup>2</sup>	2.2-Liter Engine 5-Speed Manual <sup>3</sup>	2.6-Liter Engine <sup>4,5</sup> 3-Speed Automatic
Reliant Sedan	Standard	Not Available	Not Available
Reliant Sedan SE	Standard	Optional	Optional
Reliant Wagon	Standard	Optional	Optional

<sup>1</sup>Emission Control and Testing required on all vehicles registered in California; not available otherwise.

<sup>2</sup>Not available with bucket seats.

<sup>3</sup>Bucket seats required.

<sup>4</sup>Manufactured by Mitsubishi Motors Corporation.

<sup>5</sup>Includes 75-amp alternator.

## STANDARD SAFETY FEATURES

- Anti-theft trunk lock
- Backup lights
- Brake fluid pressure loss warning light (also serves as indicator when parking brake is applied)
- Combination lap-shoulder belts for the driver and right front passenger; lap belts for all other passengers
- Dual braking system with separate brake fluid reservoirs in the master cylinder
- Energy-absorbing front seatbacks
- Energy-absorbing instrument panel and sun visors
- Energy-absorbing steering column or steering wheel
- Fade-resistant front disc brakes
- Front seat head restraints
- Hazard-warning flasher system
- Ignition and steering column lock
- Inside and outside rearview mirrors
- Key-left-in-ignition warning
- Liftgate-ajar warning light
- Safety-Rim wheels
- Seat belt reminder system
- Seatback and station wagon interior panel safety latches
- Seatback latches on folding front seats
- Side door beams
- Side marker lights and reflectors
- Turn signals with lane change feature

## OPTIONAL 5/50 SERVICE CONTRACT COVERAGE

Chrysler Corporation offers a 5/50 "Added Coverage" (in Florida "Added Value Plan") Service Contract which provides protection against rising service and parts costs for specified major repairs not included in the 5/50 Limited Warranty. Coverage starts on the specified components in the plan after your vehicle's "basic" 12-month/12,000-mile warranty expires on these components and continues for five years or 50,000 miles (whichever occurs first) from the vehicle's original warranty start date. A deductible applies.

The plan provides an allowance for alternate transportation and towing. Ask your dealer for details.

All product illustrations and specifications are based on authorized information. Although descriptions are believed correct at publication approval, accuracy cannot be guaranteed. Chrysler Corporation reserves the right to make changes from time to time without notice or obligation. In prices, specifications, colors and materials, and to change or discontinue models. See your dealer for the latest information.

MOPAR parts are engineered by Chrysler Corporation for use in your new Plymouth Reliant. When replacement is necessary, be sure to specify MOPAR parts. Used by professional mechanics all over the world.



A PRODUCT OF  
THE NEW CHRYSLER  
CORPORATION