

1967
FORD/
MERCURY

PICKUPS

CONVENTIONAL SERIES 100/250/350

Boy & Boot



Three new Ford and Mercury Pickups . . . work like trucks, ride like cars!

Ford's all-new 1967 pickups are tougher and smoother! Tougher from the frame up . . . a pleasure to drive. Compare them with cars, not trucks, as to comfort, smoothness and quiet ride! The all-new styling is functional . . . with roomier cabs and better visibility. New double-wall hood sections provide outstanding stability and rigidity. Double-wall side panels of Styleside pickup bodies protect outer walls from possible damage because of shifting cargo. Series 100/250 bring you a new idea in pickups . . . the Ranger. Ranger is Ford's all-new top-of-the-line Styleside Pickup. Series 100

Rangers are available with 115- and 131-inch wheel bases and 6½- and 8-ft. cargo boxes respectively. The Series 250 Ranger has a 131-inch wheelbase and 8-ft. box. Both the Series 100 and Series 250 have Ford's road-smoothing Twin-I-Beam front suspension. And now for '67 so does the Series 350! The Series 350 with new 135-inch wheelbase is available with 9-ft. Flareside pickup, stake and platform bodies and as chassis-cab, cowl or windshield models. New 159-inch wheelbase Series 350's are offered for commercial bodies up to 12-ft. long or 14-ft. chassis-mounted cab-over campers.



TOP LEFT, THE SERIES 100 STYLESIDE PICKUP. ABOVE, THE SERIES 100 RANGER

Twin-I-Beam Front Suspension is one big reason why Ford-Built pickups come so tough, ride so smoothly. Twin-I-Beam design has two front axles, one for each wheel. Wheels roll over bumps independently to smooth out the ride on any road. But don't let the smooth ride fool you: Twin-I-Beam front suspension is all truck. Each axle is a forged steel I-beam, like the axles on big trucks. And each axle is held in alignment by a forged steel radius rod. Quite a design . . . a design you won't find on any other pickup! First introduced in 1965 model Series 100's and 250's, a new heavy-duty version is now standard on the Series 350.

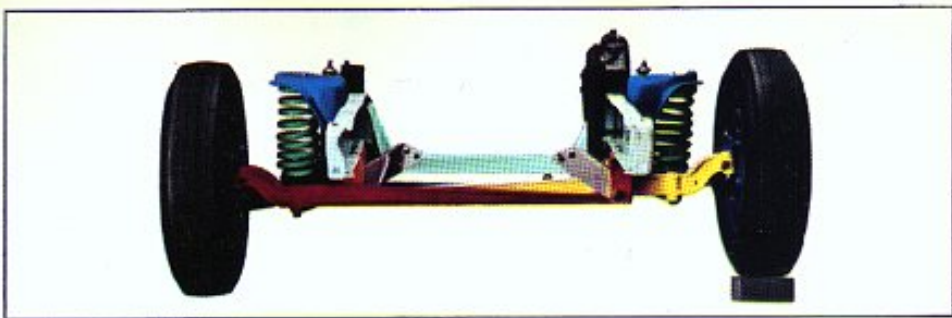

SERIES 250 FLARESIDE PICKUP

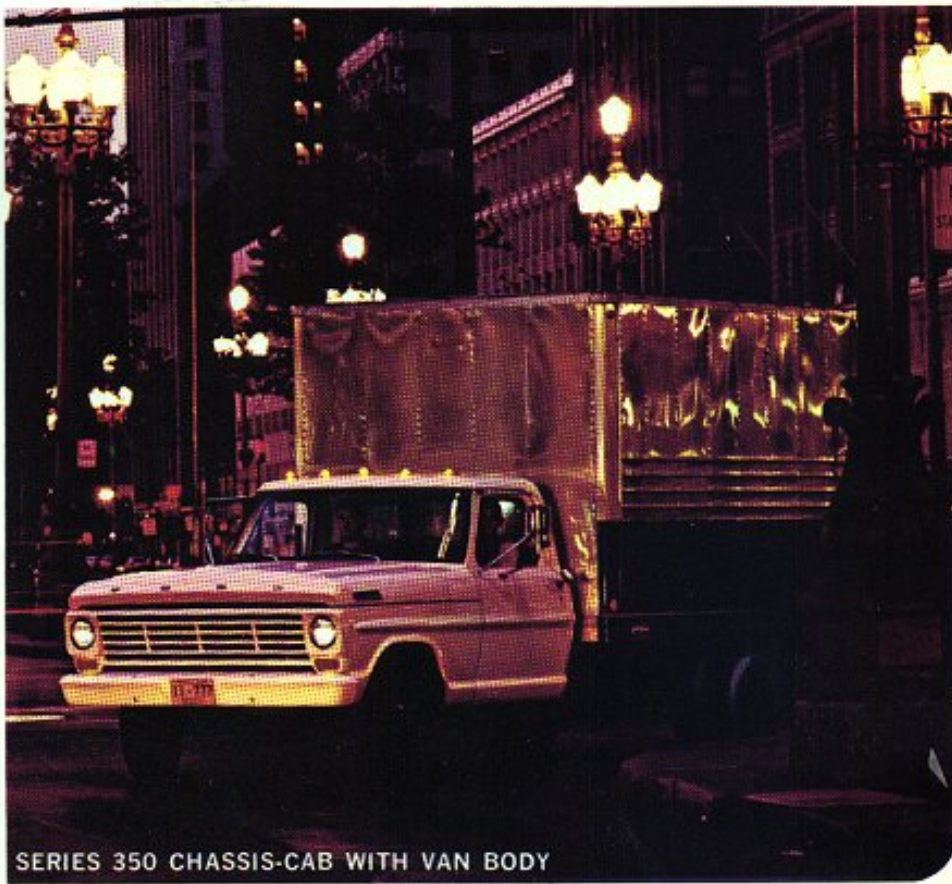

SERIES 350 CHASSIS-CAB WITH VAN BODY

More attractive, more spacious cab interiors



Everything about Ford's new interiors says comfort, luxury and spaciousness—loud and clear! You have a choice of three cab interiors . . . standard cab, Custom Cab or the exclusive cab of the Ranger. All interiors are bigger . . . nearly four inches more shoulder room. Seats are three inches wider . . . deep-cushioned and more comfortable, too. A new swept-away instrument panel provides extra space. You can even insert the ignition key either side up—it's reversible. Ford and Mercury pickups look more carlike, have more carlike features, ride more like cars and still they are the toughest Ford-Built pickups . . . ever!

RANGER—Ford's all-new, top-of-the-line Series 100/250 Styleside pickup! The full-width, deep-cushioned seat is upholstered in a highly styled durable vinyl with a soft cloth appearance. Vinyl door trim panels and nylon carpeting are handsomely trimmed with bright-metal moldings and arm rests are keyed to main body colors. The horn ring, instrument cluster, headlining and instrument padding moldings are bright-finished for added richness. Outside, bright-finished front bumper, grille and headlight assembly, hub caps, wheel lip and rocker panel moldings add extra sparkle . . . clearly identifies Ranger as Ford's finest full-size pickup.



RANGER INTERIOR (SERIES 100/250 STYLESIDE PICKUPS)

CUSTOM CAB is optional with all Series 100/250/350 Ford and Mercury Pickups. The all-new Custom Cab offers plenty of luxury and comfort! Woven-plastic seat trim in red, blue, green or beige is color-keyed to exterior paint; deep foam-cushioned, full-width seat can seat three big people comfortably; arm rests and rubber floor mat are also color-keyed to main body color; cigar-cigarette lighter; bright-finish horn ring, headlining retainer molding, instrument cluster and padded dash further add to the cab's good-looking interior. Bright-metal grille and headlight assembly, windshield reveal molding and "Custom Cab" plaques give the Custom Cab's exterior a distinctive appearance.

STANDARD CAB features include a color-keyed padded dash; attractive, functional instrument cluster; foot-operated parking brake; molded fiber-board glove box with push-button latch; bright aluminum door scuff plates; slide-action air vents for improved ventilation, easy operation; one-piece, easy-to-keep-clean hardboard headlining; and a full-width red, blue, green or beige vinyl-trimmed seat color-keyed to cab paint. Never before have Ford and Mercury standard cabs been so attractive!

STANDARD SAFETY FEATURES* on all Series 100/250/350 Ford and Mercury Pickups include seat belts for driver and passenger, seat belt anchorage for center passenger, padded dash, padded sun visors, emergency lamp flasher, backup lights, dual master cylinder hydraulic brake system with warning light, windshield washers, dual electrical 2-speed windshield wipers with non-glare wiper arms, interior and left outside rearview mirrors (pickups), left and right outside mirrors for chassis-cab, stake and platform models, non-glare instrument panel and cluster and safety door latches and hinges.
*Slight variation on chassis-cowl and windshield models.



CUSTOM CAB INTERIOR (SERIES 100/250/350)



STANDARD CAB INTERIOR (SERIES 100/250/350)

Convenience Options



Power Brakes for quicker, surer stopping—need less pedal pressure, make driving easier and safer. Available on all Series 100/250/350.



Power Steering takes the work out of parking, turning, driving. You'll appreciate power steering on the job at day's end. Available on Series 100 and Series 250.

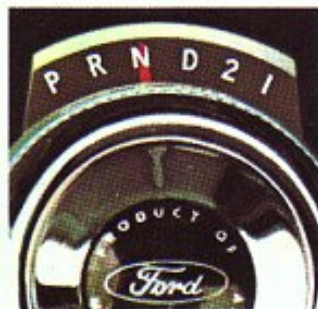

Cruise-O-Matic transmission with a "second hold" feature provides complete manual control or 3-speed automatic shifting. Excellent for slippery road traction.



Bucket Seats Series 100/250/350 add sports flair, provide individual comfort. Foam-padded vinyl-covered seats are color-keyed to exterior paint.

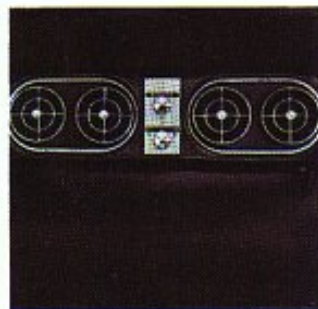

SelectAir Conditioner ends summer heat, noise, dirt, pollen and odors. This dealer-installed item cools cab and maintains a comfortable temperature.



Transistorized Radio gives you instant reception. Keeps you posted on traffic conditions, weather and news... helps ease long hours behind the wheel.

A wide choice of Fords and Mercurys to meet your needs...

STYLESIDE PICKUPS feature smooth styling with body side panels extended to hug the contour of rear cab corners. Series 100 pickups come with 6½- and 8-ft. bodies on 115- and 131-inch wheelbases respectively. Series 250 pickups have 8-ft. boxes with 131-inch wheelbases. The Styleside pickup features *double-wall* side panels and tailgate with an all-steel floor for durability. A single, center latch opens and clicks-shut the tailgate quickly and easily... and only *one* hand does it!

FLARESIDE PICKUPS have the same body lengths and wheelbases as Stylesides for both the Series 100 and Series 250. The Series 350 Flareside has a 9-ft. body with the new 135-inch wheelbase. Flareside features include running boards between cab and rear fenders for easier over-the-side loading; seasoned hardwood floorboards with steel skid strips to help slide cargo into place; rubber-covered, forged steel chains to support the tailgate, and steel side panels with rolled edges to provide extra strength and rigidity.

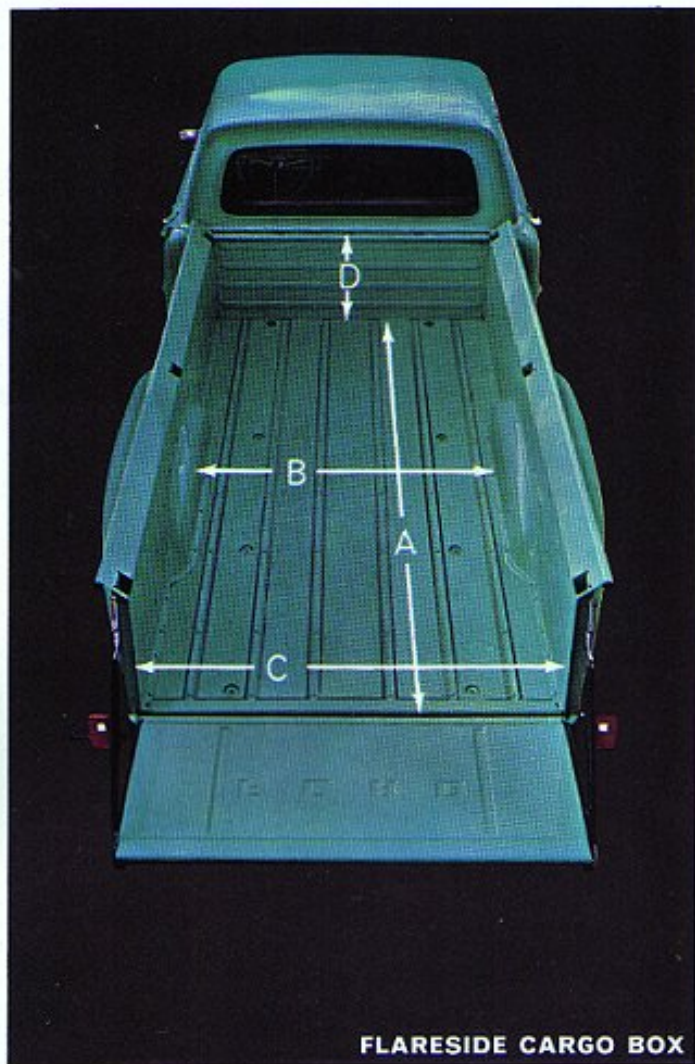
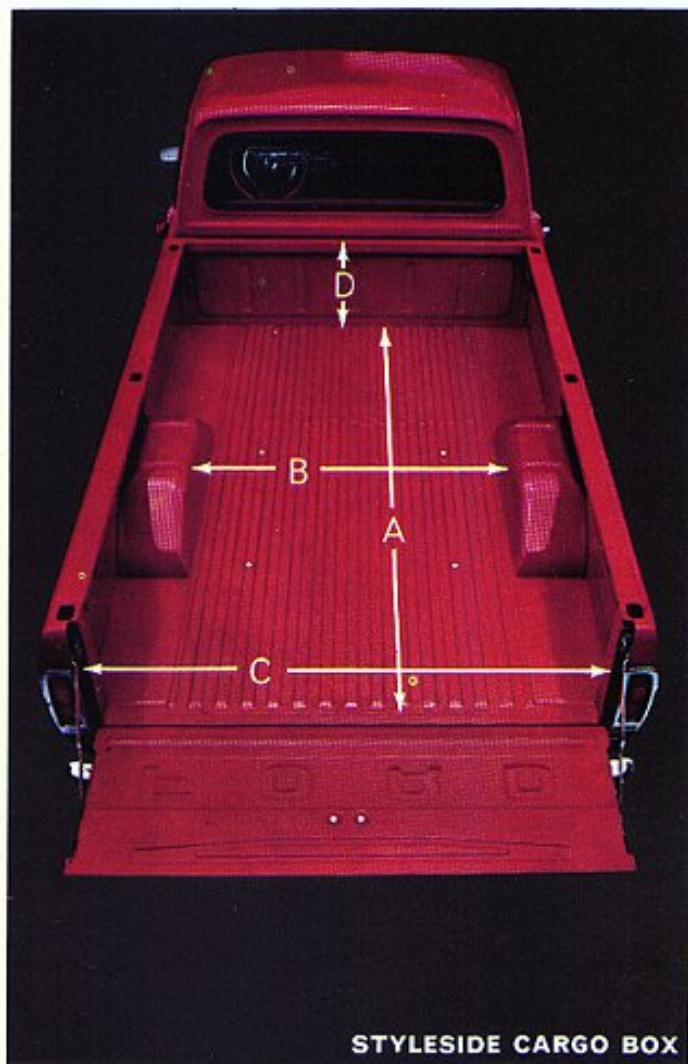

SERIES 100/250/350 CARGO AREA DIMENSIONS

MODELS	STYLESIDE			FLARESIDE				STAKE OR PLATFORM			
	"100"		"250"	"100"		"250"	"350"	"100"		"250"	"350"
WHEELBASE (in.)	115	131	131	115	131	131	135	115	131	135	159
Nominal Body Length (ft.)	6½	8	8	6½	8	8	9	6½	7½	9	12
Inside Length (in.) (A)	78.19	98.19	98.19	77.9	96.0	96.0	108.1	80.0† 82.6††	90.0† 93.4††	106.0† 109.4††	142.0† 145.4††
Width Between Wheelhousings (in.) (B)	49.0	49.0	49.0	**	48.4	48.4	48.4	—	—	—	—
Tailgate Opening (in.) (C)	65.0	65.0	65.0	49.0	54.0	54.0	54.0	67.0† 71.3††	73.7† 79.3††	82.1 87.3††	82.1† 87.3††
Floor to Top of Sides Height (in.) (D)	19.30	19.30	19.30	20.3	22.1	22.1	22.1	24.5	28.3	31.2	42.0
Cargo Capacity (cu. ft.)	60.3*	76.4*	76.4*	45.0	65.4*	65.4*	74.0*	—	—	—	—

*Allowance made for wheelhousings **No inside wheelhousings †Stake ††Platform

CHASSIS-CAB MODELS are designed to accommodate custom-built bodies. Series 100 chassis-cabs can take bodies from 5½ to 8 ft. long; Series 250's— from 6½ to 8 ft. long and Series 350— from 9 to 12 ft. long. A 12-ft. cab-over chassis-mounted camper body can be installed on a Series 350 Camper Special with a 135-inch wheelbase; 14-ft. chassis-mounted camper body can be mounted on a Series 350 Camper Special with a 159-inch wheelbase and dual rear wheels. Your Ford or Mercury Dealer will be glad to help you select the right body to meet your needs.

STAKE AND PLATFORM MODELS are designed to haul bulky and odd-shaped loads. Stake and platform models come in the following wheelbases and body lengths: Series 100 with 115" wheelbase—6½-ft. body; Series 250 with 131" wheelbase—7½-ft. body; Series 350 with 135" wheelbase—9-ft. body; Series 350 with 159" wheelbase—12-ft. body. Dual rear wheels are available with the Series 350 for greater payload capacity. Seasoned hardwood floorboards are interlocked with steel skid strips. Floor corners are reinforced with steel angle brackets.

CHASSIS-COWL AND CHASSIS-WINDSHIELD MODELS are easily adapted to single-unit bodies of the walk-in type. Series 100 chassis-cowl and chassis-windshield models are available with 115-inch wheelbase; Series 250 chassis come in 131-inch wheelbases; and Series 350 chassis are available with both 135- and 159-inch wheelbases.

See your Ford or Mercury Dealer for detailed information on special bodies and equipment to meet your requirements.

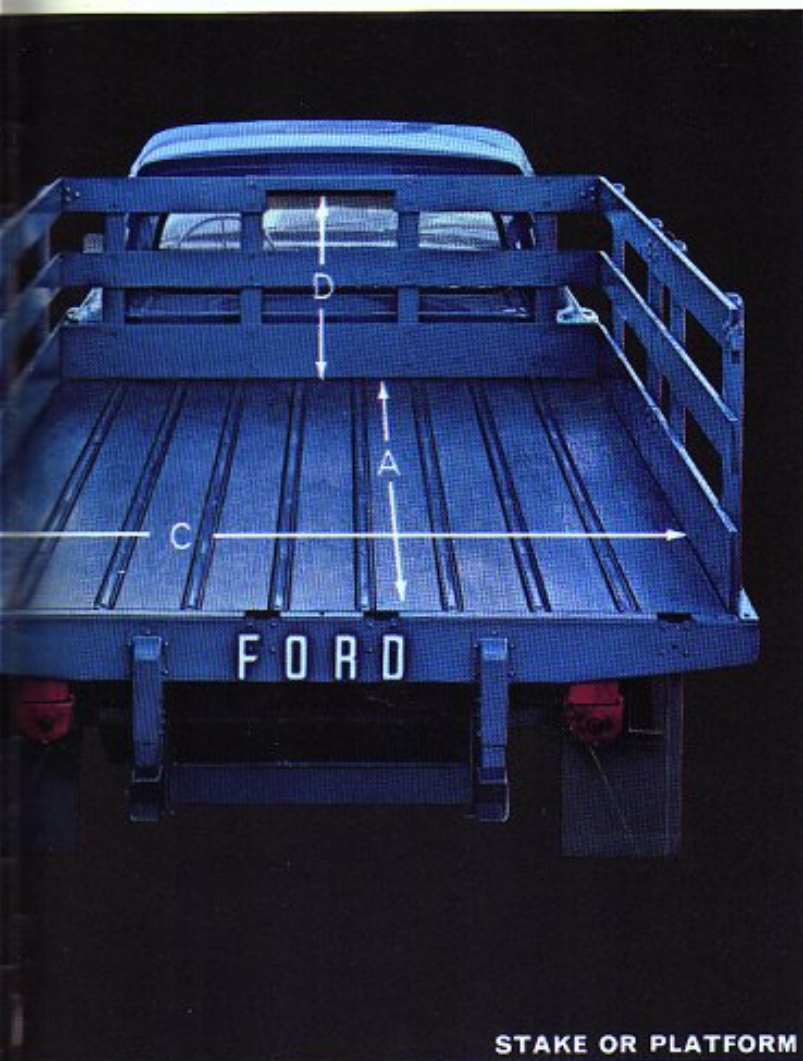

STAKE OR PLATFORM

Ford-Built Truck Body Features

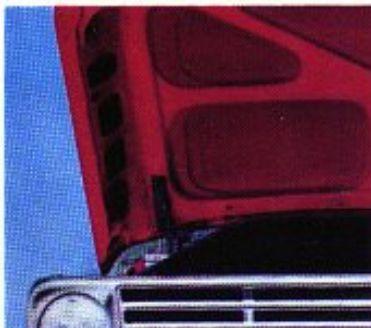

Double-Wall Hood sections provide increased hood rigidity. DOUBLE-WALL SIDE PANELS of Styleside pickups give extra strength and protect exterior sheetmetal against damage caused by shifting cargo.



One-Hand-Operated Hood Latch is standard to improve engine compartment accessibility. No groping with two hands . . . the new latch is easy to reach and open with just one hand!



One-Hand Tailgate Latch on Styleside pickups. Pull—tailgate opens to a horizontal position. Push—it snaps shut automatically. Center latch releases tailgate in one easy motion. Only one hand does it!



Flareside Running Board is a wide, ribbed steel step between the cab and rear fenders to permit easy loading from either side. Running board is standard equipment on Series 100/250/350 Flareside pickups.

SERIES 100/250/350 CHASSIS-CAB DIMENSIONS

DIMENSIONS (in.)	"100"	"250"	"350"
Wheelbase (WB)	115	131	135
Front bumper to front axle (A)	30.7	30.7	30.7
Front bumper to back of cab (B)	105.7	105.7	105.7
Back of cab to rear axle (C)	40	56	60
Rear axle to end of frame (D)	36.8	40.6	38.5
Frame to cab roof height (E)	47.5	47.5	47.5
Frame to ground height (F)	24.0	23.7	24.9
Overall length (G)	182.5	202.3	204.2

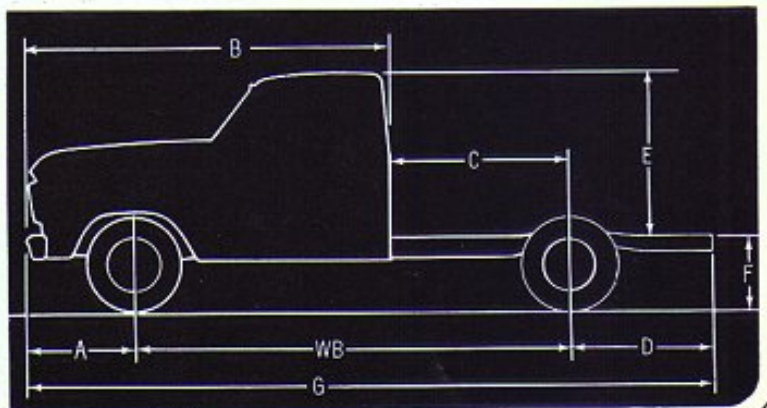

4 Seasons of fun with Camper Specials

Every year more and more families are discovering that a Camper Special is the reliable way to enjoy North America's great outdoors. Ford and Mercury Series 100/250/350 Camper Specials are specially designed and engineered to carry your camper and equipment with optimum reliability, durability and economy.

You can take off on weekend or vacation hunting, fishing or camping trips in your Camper Special by Ford... North America's leader in recreation-type vehicles. The new '67 Camper Special Package is now available on a new 135-

inch wheelbase Series 350 chassis-cab model that can carry a 12-ft. cab-over camper body. The 159-inch wheelbase model, as illustrated, can haul up to a 14-ft. camper body.

Ford and Mercury Camper Specials are engineered to provide the special heavy-duty components needed to haul a camper body. They remove the guesswork and bother of ordering components individually. Your Ford or Mercury Dealer will be glad to assist you in selecting the Ford Camper Special model and a camper body to meet your recreational needs!



Series 350 Chassis-Cab Camper Special with 14-ft. Chassis-mounted Camper