



Ford Custom 500 4-Door

1966 Ford



Police Cars & Emergency Vehicles

AMERICA'S NO. 1 POLICE CAR



Ford Custom 2-Door; both 2- and 4-door models available in Custom and Custom 500 series

FORD POLICE CARS... built for round-the-clock action!

America's No. 1 police car comes in ten distinct models this year in the Ford, Fairlane and Falcon series. Leading off is the big Ford with searing power for highway pursuit, solid stamina for stop-go city driving and comfortable riding for the men on patrol. Ford's new Interceptor Package for police cars boasts a powerful 428-cu. in. engine... a real scorcher that turns out 360 horsepower with top speeds well in excess of 100 mph. For greater stopping ability under severe conditions of repeated hard stops, Ford offers optional power disc front brakes. There are five Ford "Police Special" Packages with engines ranging from a thrifty 240-cu. in. Six through the mighty Interceptor.

Ford's widely acclaimed full-coil suspension system delivers better control, smoother riding and greater safety on all types of roads. Wide 62-inch front and rear treads plus low-profile tires are among the many features that give Ford excellent road-holding ability.

Designed for *total* performance, Ford Police Cars also deliver *total* economy. The famous Ford-pioneered service-saving features help keep Ford Police Cars in top condition with a minimum of shop time and maintenance costs. '66 Ford Police Cars are available in the Custom 500 and Custom series, both with 2- and 4-door models. A wide range of special police car options is offered.

5 SERIES, 10 MODELS

Ford Custom 500: 2-Door Sedan, 4-Door Sedan

Ford Custom: 2-Door Sedan, 4-Door Sedan

Ford Wagons: Ranch Wagon, Country Sedan, Country Sedan with dual-facing rear seats

Fairlane: Club Coupe, 4-Door Sedan

Falcon: Club Wagon



Ford Country Sedan, one of three Ford Police Wagons

FORD POLICE WAGONS ... best all-round police vehicles!

And that's a fact! Start with Ford's clever, versatile Magic Doorgate. It can be swung down in conventional manner for loading emergency gear or opened to the side like a door to admit passengers and to load stretchers. And only Ford-built wagons have it. Ford wagons are really big inside, too. The second seat easily folds down with one hand to provide a total loadspace of 103 cubic feet in the 6-passenger model. This includes a locked storage compartment under the floor that can stow first aid and other equipment securely out of the way. A full 48 inches between the wheelhouses can accommodate large, awkward loads. For carrying more than six, there's

also a model with Ford's unique dual-facing rear seats.

Ford's exclusive built-in rear-pillar air deflectors direct a stream of air across the rear window to help keep it free of dirt and snow. A flat, level floor, stand-up spare tire stowage, and a second seat that can be unlatched and folded down from *either side* are other important Ford features. Power-operated rear window is standard on dual-facing rear seat model, optional on others. Ford Police Wagons are available in Ranch Wagon, Country Sedan (6-passenger) and Country Sedan with dual-facing rear seats. Any Ford "Police Special" Package may be specified including the Interceptor with mighty 428-cu. in. engine.



New Magic Doorgate, standard on all Ford wagons, opens like a door (above left) or swings down like a regular tailgate (above). And it's all as easy as turning the door handle. To protect the rear window, the Doorgate cannot be opened unless the window is in fully retracted position.



FAIRLANE POLICE CARS . . . economy, room and plenty of "go"!

Here's the way to work total performance into the most modest budget. Fairlane is all new for '66 but still carries its famous low price tag. Fairlane's genuine reputation for quality together with a long list of service-saving features make it an inexpensive police car to maintain. And when it comes to room, this car's got it. Even outdoes the big cars in some important comfort dimensions.

But the biggest news for '66 is performance—Fairlane's total performance. The Trooper Package for Fairlane Police Cars features a 390-cu. in. engine . . . a real powerhouse that turns out 335 hp. Three other engines, including a thrifty 200-cu. in.

Six, furnish a full range of police performance options.

Fairlane rides smoother in '66, thanks to refinements in the integral body-frame design. Front and rear structural members are welded to torque boxes which act as "isolation chambers" and help absorb road shock and vibration before they can be transferred to the body. A new sound package utilizes improved insulation materials to give a quieter, more relaxing ride . . . helps cut fatigue, keeps patrolmen more alert. An all-new heater-defroster provides living-room comfort in the most frigid weather. Fairlane Police Cars are available in 2-door and 4-door models with a list of options to fit your needs *and* your budget.



Fairlane Club Coupe shown here; Fairlane 4-Door Sedan also available



Falcon Club Wagon in standard (top) and optional extended body models

FALCON police utility vehicles

One good look tells why the Falcon Club Wagon is such an excellent police utility vehicle. It's roomy inside with a flat, level floor that stretches nearly nine feet long and five feet wide, for a total cargo volume of 194 cu. ft! Double doors at rear and curbside swing open four feet wide for easy loading. Like all Falcons, economy is a big feature . . . now, at purchase time and throughout the long life of the vehicle. Standard are the 170-cu. in. Falcon Six with Synchro-Smooth Drive for shifting ease and economical city operation. A long list of options, including a 240-cu. in. Big Six engine, 3-speed Cruise-O-Matic Drive and new Extended Body (242 cu. ft.), make this wagon a real workhorse in a host of duties for law enforcement agencies.

SPECIAL EMERGENCY VEHICLE WAGON CONVERSION OPTIONS

Ford Police Wagons can be modified for special patrol wagon, ambulance, auxiliary fire fighting, rescue and other emergency uses. These conversions are fully tested and proved. Complete details and conversion options data are available from your Ford Dealer.



Patrol Wagon conversion, one of many applications for Falcon Club Wagons



Ambulance conversion by Automotive Conversion Corp., Birmingham, Michigan

FORD "police special" packages

These five packages . . . sold only to law enforcement agencies . . . are available with any Ford Police Car to tailor the car's performance to your local requirements.

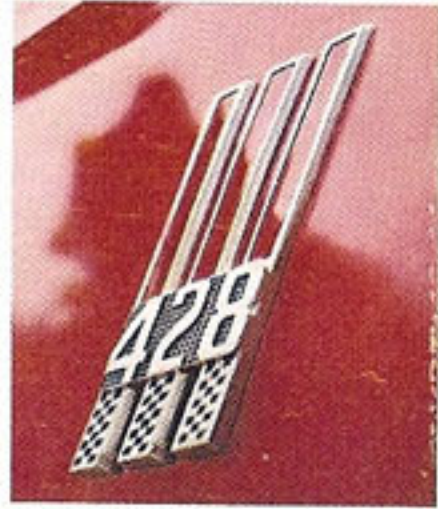

INTERCEPTOR

The heart of this husky package is the powerful, new 428-cu. in. V-8 Interceptor engine. This powerplant is designed and built for fast takeoffs, sustained high-speed driving and round-the-clock patrol work. The 360-hp Interceptor's high performance and dependability are the result

of a free-breathing induction system with a high velocity 4-venturi carburetor, direct-flow Super-Filter air cleaner and dual, low back-pressure mufflers.* The valve train features a high-lift camshaft, solid lifters, precision-fitted exhaust valves, high perfor-

*Dual mufflers not included on wagons

mance valve springs with one-piece retainers and internal damping springs.

The Interceptor Package also includes: 80-Amp. Heavy-Duty Battery • 42-Amp. Alternator with Dual Belt Drive • High Speed and Handling Package with Heavy-Duty Front and Rear Springs, Extra-Control Shock Absorbers and a Heavy-Duty Link-Type Stabilizer Bar • Heavy-Duty Fade-Resistant Brakes with Manual Adjusters • Calibrated Speedometer with 2-Mile-Per Hour Increments • Heavy-Duty Front Seat with Foam Padding • Extra Cooling Package • Heavy-Duty Front and Rear Black Rubber Floor Mats • 15" Wheels with 6" Rims.

CRUISER

The Cruiser Package is built around a 390-cu. in., 4-barrel V-8 engine. This big 315-hp engine delivers fast acceleration, high road speeds and dependable service. It is recommended when the extra high perfor-

mance of the Interceptor is not required. Aside from the engine and 70-amp. battery, the Cruiser shares all other special police features with the Interceptor.†

GUARDIAN

This package is based on a 390-cu. in., 2-barrel V-8 engine. Designed to use regular fuel, this 275-hp engine combines dependable performance with all-round operating economy. All other features except the 70-amp. battery are the same as listed under Interceptor.†

SENTINEL

The Sentinel engine is a snappy 289-cu. in., 200-hp V-8! Fills the bill when both V-8 power and operating economy are requirements. Aside from engine, 70-amp. battery and extra cooling package, the Sentinel shares all "Police Special" features with the Interceptor.†

DEPUTY

This package is powered by a 240-cu. in., 150-hp 6-cylinder engine with real pep and traditional Ford Six economy. Seven main bearings give exceptional smoothness and durability. All other features except 70-amp. battery and extra cooling package are the same as listed under the Interceptor Package.†

†42-amp. alternator is dual belt drive on Interceptor only, all other packages are single belt drive

FORD POLICE CAR POWER TEAM SELECTIONS

PACKAGE	INTERCEPTOR	CRUISER	GUARDIAN	SENTINEL	DEPUTY
ENGINES	Interceptor V-8	Thunderbird Special V-8	Thunderbird V-8	Challenger V-8	Police Special Six
Displacement (cu. in.)	428 4V	390 4V	390 2V	289 2V	240 1V
Horsepower @ rpm	360 @ 5400	315 @ 4600	275 @ 4400	200 @ 4400	150 @ 4000
Torque (lbs-ft) @ rpm	459 @ 3200	427 @ 2800	405 @ 2600	282 @ 2400	234 @ 2200
Compression Ratio (to 1)	10.5	10.5	9.5	9.3	9.2
Alternator	42 amp. (dual)	42 amp. (single)	42 amp. (single)	42 amp. (single)	42 amp. (single)
Transmission	Cruise-O-Matic†	3-speed Man.	Cruise-O-Matic†	3-speed Man.	HD 3-speed Man.
Clutch (dia. in.)	11.5	11	N.A.	10.4	11
Battery (amp-hr)	80 HD	70 HD	70 HD	70 HD	70 HD
AXLE RATIOS					
3-Speed Manual	N.A.	3.25 (3.50)	N.A.	3.50	3.50
4-Speed Manual (opt.)*	3.25 (3.50)	3.25 (3.50)	N.A.	N.A.	N.A.
Overdrive (opt.)	N.A.	N.A.	N.A.	3.50	3.50
Cruise-O-Matic (opt.)	3.00 (3.25)	3.00 (3.25)	3.00 (3.25)	3.50	3.50

Axles per ratios listed are available with either manual or optional self-adjusting brakes. Optional ratio shown in parenthesis.
*Not available on wagons †Optional

FAIRLANE "police special" packages

Fairlane 2-door and 4-door sedans can be equipped with any of these four special police car packages.

TROOPER

A powerful 390-cu. in., 4-barrel V-8 engine gives Fairlane plenty of power and speed for pursuit or sustained highway patrol work. This 335-hp engine is designed and built for smooth, dependable and efficient performance all day long at normal road patrol speeds.

The Trooper Package includes: 42-Amp. Alternator with Single Belt Drive • Heavy-Duty Battery—70 Amp. • Heavy-Duty Front Springs, Rear Springs and Shock Absorbers • Heavy-Duty Black Rubber Floor Mats, Front and Rear • Extra Cooling Package • Heavy-Duty Wear-Resistant or Fade-Resistant Brakes • Calibrated Speedometer with 2-Mile-Per-Hour Increments • Heavy-Duty Front Seat with Foam Padding.

PACER

This popular package now features a 390-cu. in., 2-barrel V-8. This snappy 265-hp engine delivers fast acceleration and high speeds second only to the Trooper engine. All other special features are identical to those in the Trooper Package.

RANGER

Powered by a 289-cu. in., 200-hp V-8, the Ranger Package gives the Fairlane police car good power and speed with unusually thrifty operation. With the exception of the engine, the Ranger has all the special features listed under the Trooper.

SENTRY

This package is built around the thrifty 200-cu. in., 120-hp, 6-cylinder engine. It's a fine performer in city traffic patrol work where economy and dependability are most important. 3-speed transmission with heavy-duty clutch is standard. All other package features are shared with the Trooper.

FAIRLANE POLICE CAR POWER TEAM SELECTIONS

PACKAGE	TROOPER	PACER	RANGER	SENTRY
ENGINES	Thunderbird Spec. V-8	Thunderbird V-8	Challenger V-8	Fairlane Six
Displacement (cu. in.)	390 4V	390 2V	289 2V	200 1V
Horsepower @ rpm	335 @ 4800	265 * @ 4400	200 @ 4400	120 @ 4400
Torque (lbs-ft) @ rpm	427 @ 3200	401** @ 2600	282 @ 2400	190 @ 2400
Compression Ratio (to 1)	10.5	9.5	9.3	9.2
Alternator	42 amp. (single)	42 amp. (single)	42 amp. (single)	42 amp. (single)
Transmission	3-speed Man.	3-speed Man.	3-speed Man.	3-speed Man.
Clutch (dia. in.)	11.5	11	10.0	10.4
Battery (amp-hr)	70 HD	70 HD	70 HD	70 HD
AXLE RATIOS				
3-Speed Manual	3.00 (3.25) /3.00/	3.00 (3.25) /3.00/	2.80 (3.25) /3.00/ 3.25†	3.25 (3.50) /3.25/ 3.25† 3.25#
4-Speed Manual (opt.)	3.00 (3.25) /3.25/	3.00 (3.25) /3.25/	3.25 (2.80) /3.25/ 3.25†	N.A.
Overdrive (opt.)	N.A.	N.A.	3.50	N.A.
Cruise-O-Matic (opt.)	3.00 (3.25) /3.00/	3.00 (3.25) /3.00/	2.80 (3.00) /3.00/ 3.00†	2.80 (3.25) /3.25/ 3.25† 3.25#
Axles per ratios listed here are available with self-adjusting brakes only except where noted. Optional ratio shown in parenthesis. Limited-slip differential axle ratio shown in brackets. *275 @ 4400 with Cruise-O-Matic Drive. **405 @ 2600 with Cruise-O-Matic Drive. #Optional wear-resistant (bonded), manually adjusted brake axle ratio. †Optional fade-resistant (riveted) brake axle ratio.				

Alternator Selection

Alternators must meet the electrical load requirements for the vehicle at average driving speeds, plus supply sufficient output to charge the battery. To determine the required alternator size, find the electrical item group in the Ampere-Draw Table that best describes your vehicle equipment. Alternators recommended are for 20-mph average vehicle speed. If your average speed is other than 20 mph, contact your dealer or local Ford District Sales Office for detailed selection information.

FORD ALTERNATORS

- 42-Amp. Ford-Autolite
- 53-Amp. Pancake (Leece-Neville)
- 55-Amp. Ford-Autolite
- 60-Amp. HD Pancake (Leece-Neville)

AMPERE-DRAW TABLE

Electrical Equipment Groups	Average Ampere Draw	Recommended Alternator
STANDARD LOAD: Includes ignition, gauges, regulator, all lighting turned on by headlamp switch, heater motor, electric wipers plus All-Transistor, Two-Way Radio	28	42-Amp. Ford-Autolite
Standard Load plus: Tube-Type Two-Way Radio; or Transistor Ignition; or Ford Air Conditioner*	32	55-Amp. Ford-Autolite
Standard Load plus: Transistor Ignition and Ford Air Conditioner*	34	55-Amp. Ford-Autolite
Standard Load plus: Tube-Type Two-Way Radio and Transistor Ignition; or Tube-Type Radio and Ford Air Conditioner*	42	60-Amp. HD (Leece-Neville)

FAIRLANE ALTERNATORS

- 42-Amp. Ford-Autolite
- 53-Amp. Pancake (Leece-Neville)
- 55-Amp. Ford-Autolite

AMPERE-DRAW TABLE

Electrical Equipment Groups	Average Ampere Draw	Recommended Alternator
STANDARD LOAD: Includes ignition, gauges, regulator, all lighting turned on by headlamp switch, heater motor, electric wipers plus All-Transistor, Two-Way Radio	27	42-Amp. Ford-Autolite
Standard Load plus: Ford Air-Conditioner*	28	42-Amp. Ford-Autolite
Standard Load plus: Tube-Type Two-Way Radio with or without Ford Air Conditioner*	32	55-Amp. Ford-Autolite

*Ford SelectAire has 55-amp. alternator as standard equipment



Police car options

FORD

HIGHLY RECOMMENDED OPTIONS

Cruise-O-Matic Drive (see RPO)
 Power Steering (RPO)
 Power Disc Front Brakes (RPO)
 Vinyl Trim Set (LPO)

RPO—Monthly Schedule Items

Cruise-O-Matic Drive
 4-Speed Manual Fully Synchronized Transmission (428 and 390 4V V-8's only, not avail. on wagons)
 Overdrive Transmission (240 Six and 289 V-8 only)
 Power Brakes*
 Power Disc Front Brakes
 Power Steering
 Power Seat
 Power Wagon Rear Window (std. Country Sedan with dual-facing rear seats)
 Deluxe Seat Belts, Front & Rear, Front Retractors
 Safety/Convenience Control Panel—vacuum door locks, door ajar warning light, low fuel warning light, seat belt reminder light and emergency flashers
 Visibility Group—remote-control mirror, day/night mirror, 2-speed wipers
 Axle Ratios—see power team selection chart
 Limited-Slip Differential—includes fade-resistant brakes with self adjusters and HD axle
 Push-Button AM Radio with Front Antenna*
 Push-Button AM/FM Radio and Front Antenna*
 Radio Antenna—right rear quarter
 Tinted Glass with Banded Windshield
 Power Windows
 SelectAire Conditioner
 Courtesy Light Group—ash tray, parking brake signal, glove box, trunk lights, front and rear door courtesy switches
 Headlamp Covers
 Chrome Luggage Rack (wagons only)
 Automatic Speed Control (V-8 & Cruise-O-Matic required)
 Fold-Down Rear Seat (4-door sedans)
 Two-Tone Paint
 MagicAire Heater†

LPO—Limited Production Items

Alternators—Pancake Type with Built-In Silicon Rectifier (see page 7)

Vinyl Trim Set, Non-Pleated, Beige—includes 2 visors, front & rear arm rests, ash trays, black steering column, instrument panel and garnish moldings, black rubber floor mats

Extra Cooling Package
 Single Key Locking System
 Radio Noise Suppression Equipment
 Spotlight—left hand, "A" pillar mounted, clear lens without mirror, 6" diameter
 Dual Wiring for Roof Beacon (with grommet in roof panel)
 Transistorized Voltage Regulator
 2-Speed Electric Windshield Wipers

DSO—Special Order Items

Flexible Conduit for Radio Cable—1½" I.D. (sedans only)
 Pace Type Speedometer with Needle Stop
 Spotlight—pillar-mounted, right hand, clear lens, 6" diameter
 Suppression Spark Plugs with Non-Suppressed Ignition Wiring
 Hand Throttle, Locking Type
 Charge Indicator Gauge (standard with 60-amp. alternator)
 Oil Pressure Gauge
 Spare Tire Relocation—to right rear of luggage compartment (sedans only)
 Glove Box and Front Ash Tray Light
 Map Light—located under instrument panel

Dealer Installed Items

Fire Extinguishers
 Bumper Guards, Front & Rear (front only on wagons)
 Electric Clock
 Mud & Stone Deflector (wagons only)
 Rubber Cargo Deck Mat (wagons only)
 Ford Air Conditioner
 Bumper Steps (for 6-pass. wagons)

FAIRLANE

HIGHLY RECOMMENDED OPTIONS

Cruise-O-Matic Drive (see RPO)
 Power Steering (RPO)
 Vinyl Trim Set (4-door only) (LPO)

RPO—Monthly Schedule Items

Cruise-O-Matic Drive
 4-Speed Manual Fully Synchronized Transmission (V-8 engines only)
 Overdrive Transmission (289 V-8 only)
 Power Brakes*

Power Steering
 Deluxe Seat Belts, Front & Rear, Front Retractors
 Visibility Group—remote-control mirror, day/night mirror, 2-speed electric wipers
 Electric Clock*
 Axle Ratios—see power team selection chart
 Limited-Slip Differential
 Push-Button Radio*
 SelectAire Conditioner
 Courtesy Light Group—ash tray, map, glove box, trunk (cargo wagon) lights, front & rear door courtesy switches
 Tinted Glass
 Two-Tone Paint
 MagicAire Heater†

LPO—Limited Production Items

Alternators—Built-In Silicon Rectifier (see page 7)
 Dual Wiring for Roof Beacon (with grommet in roof panel)
 Radio Noise Suppression Equipment
 Extra Cooling Package
 Transistorized Voltage Regulator
 2-Speed Electric Windshield Wipers
 Vinyl Trim Set (4-door only)

DSO—Special Order Items

Ammeter
 Oil Pressure Gauge
 Glove Compartment Light*
 Single Key Locking System
 Inside Non-Glare (Day/Night) Mirror*
 Spotlight—left or right hand, without mirror, clear lens
 Suppression Spark Plugs with Non-Suppressed Ignition Wiring
 Hand Throttle, Locking Type

Dealer Installed Items

Fire Extinguishers
 Parking Brake Warning Light

*Also dealer installed

†Heater-defroster is standard equipment. However, this option may be deleted if desired on appropriate price reduction.

Explanation of Terms

RPO—Regular Production Option. Equipment advertised nationally and available without delay in production.

LPO—Limited Production Option. Equipment generally used only by fleet and commercial accounts.

DSO—Domestic Special Order. Specific procurement, with time necessary to fill order.

FORD . . . America's No. 1 Police Car inside and out!



Ford Police Car interiors are designed for durability and comfort in duty around the clock, day in and day out. Here's how: Heavy-duty seats are scientifically angled for the most restful back support. Heavy-gauge front seat springs, covered with foam-padded cushions, provide driver-passenger seating comfort and give firm support. Front seat track allows over five inches of adjustment, backward and forward.

There's plenty of room inside, too. Thanks to a low front floor tunnel, forward-sloping instrument panel, practical roofline and curved side glass. Dash panel knobs, controls and ignition lock are conveniently grouped, lighted at night. Reversible key is an added touch of convenience. Padded instrument panel and sun visors, outside rearview mirror, backup lights, windshield washers and single-speed wipers, emergency flashers, front and rear seat belts are standard for greater safety.

Cloth-and-vinyl or optional all-vinyl upholstery is durable and easily cleaned. Rugged all-vinyl headlining and door panel trim are neat looking and stay clean longer.

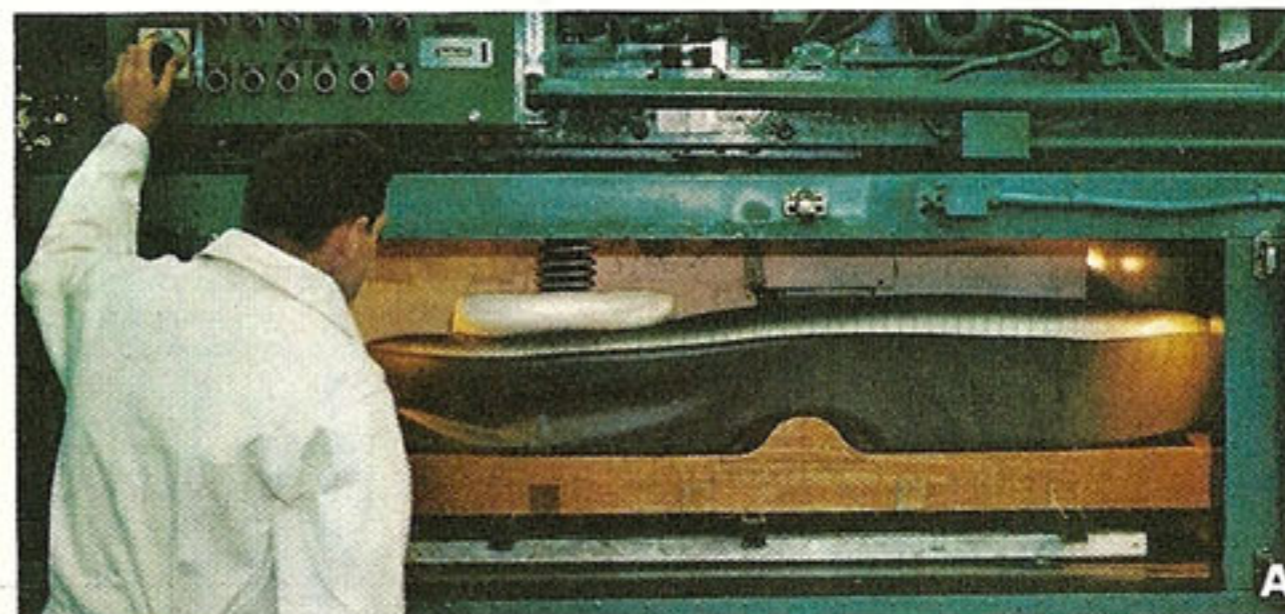

A. Heavy-Duty Seats feature higher capacity springs and thick padding to last longer and stay comfortable longer under the rough usage of police work. Special testing equipment at Ford Engineering checks reliability and durability.

B. Heavy-Duty Fade-Resistant Brakes feature 225-sq. in. riveted linings and air-groove-cooled, composite drums for consistent high-speed braking. Choice of manually adjusted or optional self-adjusting brakes. For greater fade resistance, straight-line stopping ability and longer lining life, Ford offers power disc front brakes as an option. (See page 11.)

C. Wide Sweep Visibility in fair weather or foul is achieved by Ford's full-view windows and tandem-action, constant-speed electric wipers. Dependable wiping action plus wide pattern add up to a clearer view of the road in all bad weather conditions.

D. Padded Instrument Panel, standard on all Ford Police Cars, is an important safety feature. It's constructed of impact-absorbing padding covered with vinyl.

FAIRLANE...policeman-size room and comfort!



Slip into the '66 Fairlane Police Car. Greater foot clearance and a new covered front floor make entry much easier. A complete new body with curved side glass supplies more room inside. Scientifically angled seats provide firm, comfortable support. Heavy-duty construction with foam cushions keeps seats comfortable longer, too. Front seat tracks give 5-inch front-to-rear adjustment. There's new convenience inside, too, with a suspended accelerator pedal, improved steering wheel angle, safety/courtesy lighting and lighted Cruise-O-Matic quadrant.

For greater safety, padded instrument panel and sun visors, outside rearview mirror, backup lights, front and rear seat belts, emergency flasher, windshield washers and single-speed wipers are standard.

The real surprise comes behind the wheel of a '66 Fairlane, however. A new "sound package" consisting of insulation and mastic deadener makes the passenger compartment more comfortable and relaxing on long patrols. Standard cloth and vinyl or optional all-vinyl upholstery is good looking, durable and stays cleaner longer.

- A. Plush New Ride, Improved Handling** are achieved through an improved suspension and wider tread (58 inches front and rear). Manual steering is easier due to a higher overall numerical ratio (29.4 to 1).
- B. Foot-Operated Parking Brake** is convenient to apply and release. It holds better, too, because it's so easy to operate. Parking brake and all other pedals are suspended to give a clean, uncluttered floor. These features are in the big Ford as well.
- C. Fairlane's New Reversible Key** for doors and ignition goes in lock either side up for new ease in locking and unlocking doors. Another feature Fairlane has in common with the full-size Ford. Safety-Yoke door latches are built stronger to hold doors tighter for greater safety.
- D. Full Padded Dash** features impact-absorbing padding topped with vinyl. Provides greater safety and gives the instrument panel a more attractive appearance. It's standard on all Ford Police Cars.

Try a Ford police car on for size!

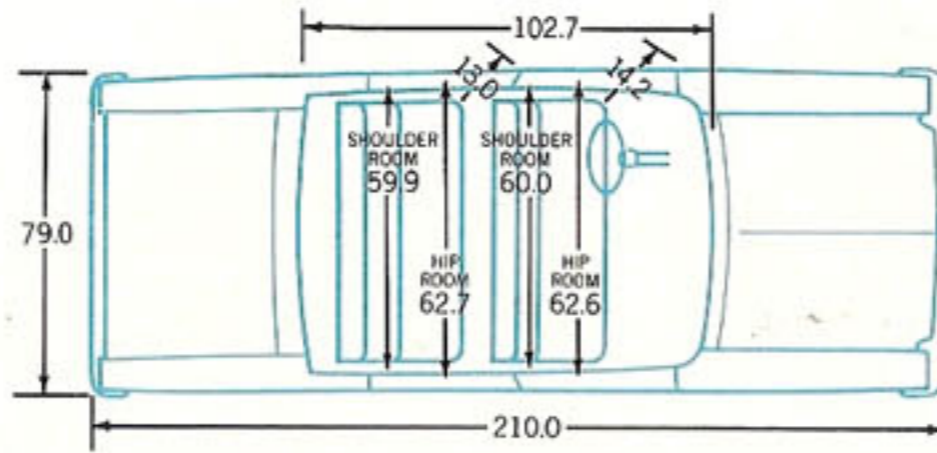
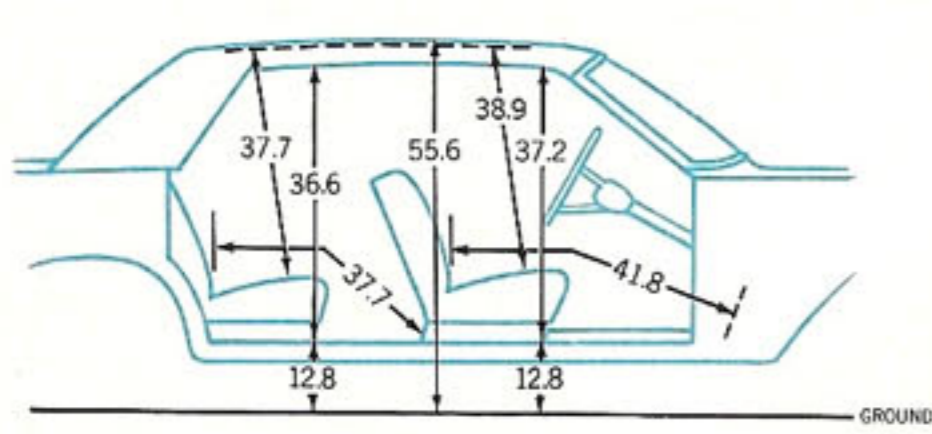

FORD SEDAN

There's room enough in a Ford Police Car for six husky men to sit comfortably. Greater foot clearance makes getting in and out easy, too.

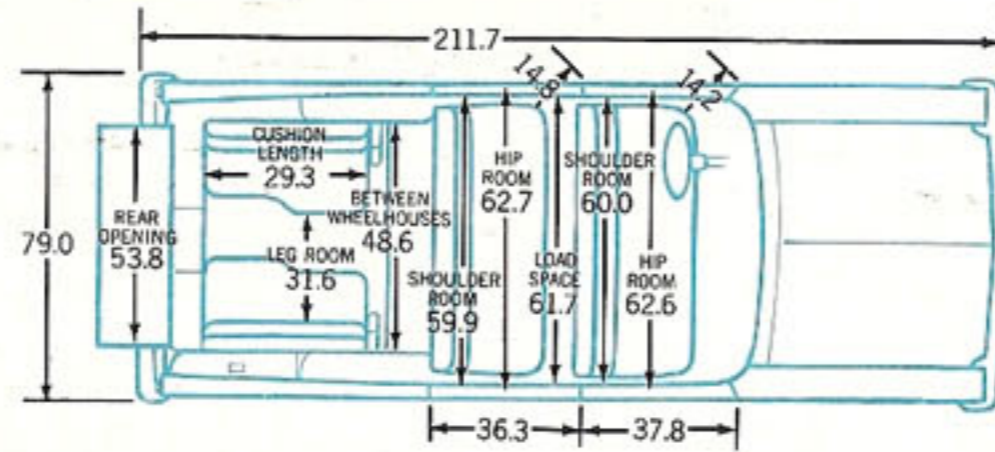
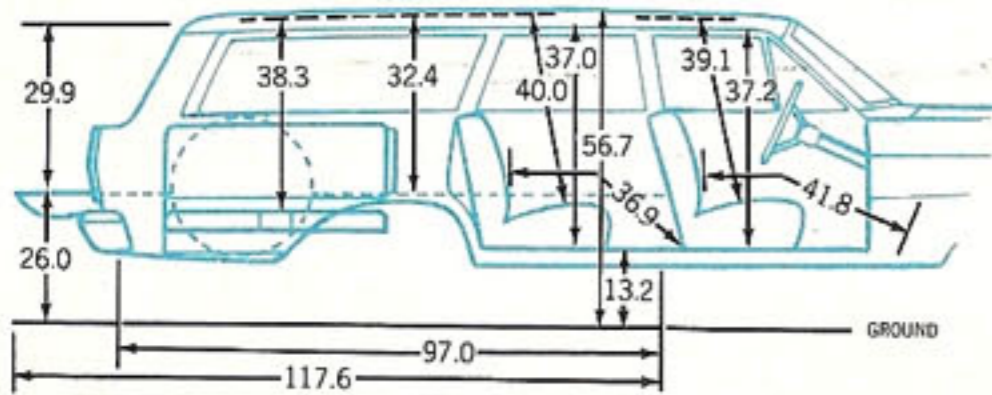

FORD WAGON

Get plenty of room for seating comfort, lots of loadspace and easy loading in any one of three versatile Ford wagons.

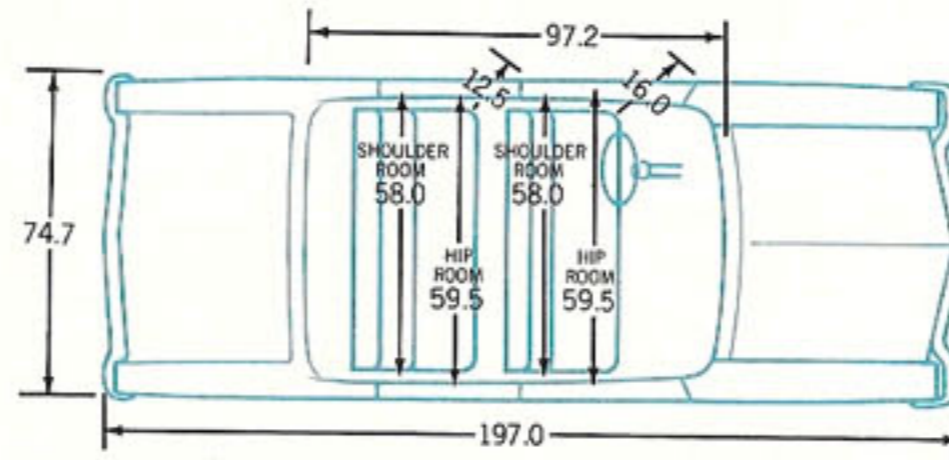
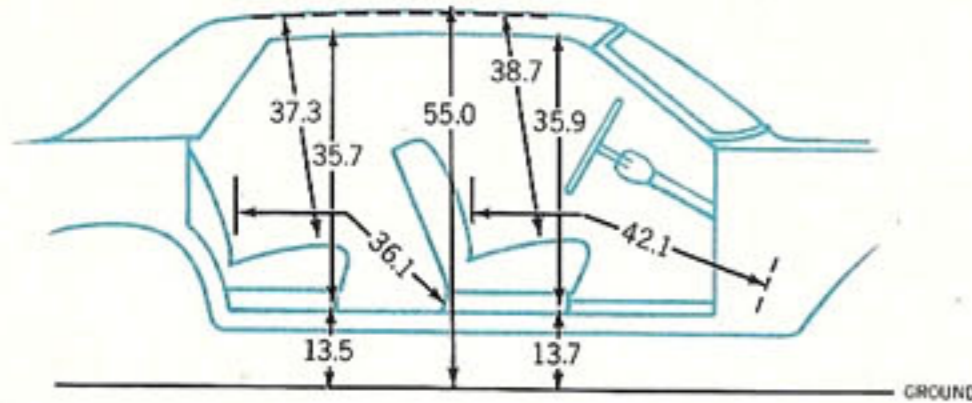

FAIRLANE SEDAN

For a car of its handy, easy-to-manage size, Fairlane is surprisingly roomy inside with big trunk space.

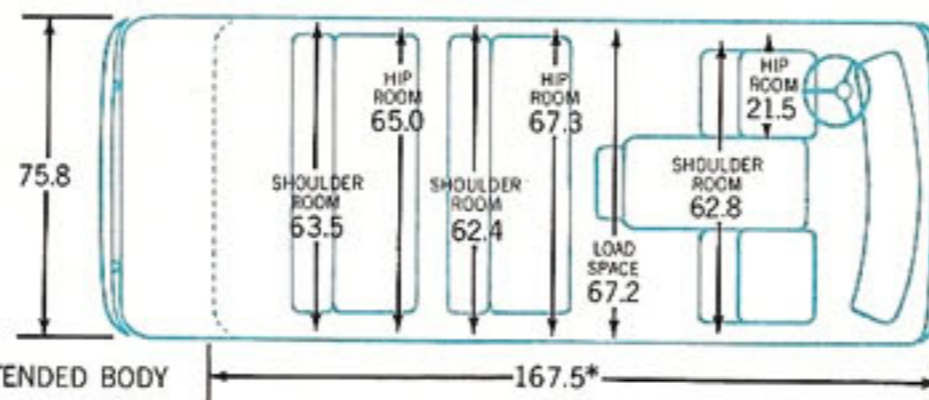
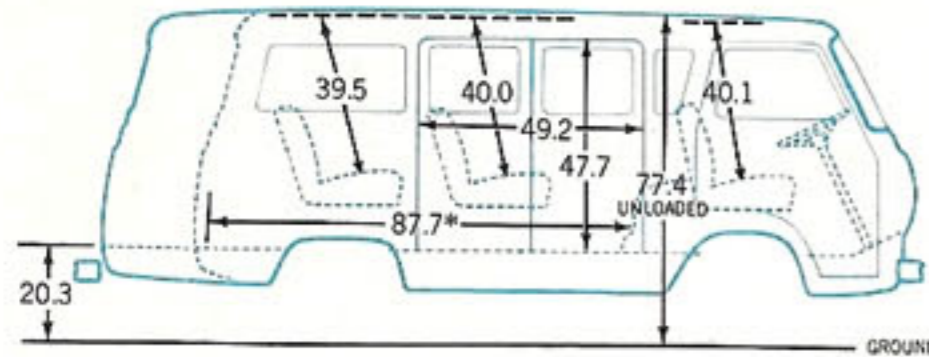

FALCON CLUB WAGON

These vehicles are compact, easy to load and feature 194 cu. ft. of cargo space. No wonder they make such fine utility wagons.



POWER DISC FRONT BRAKES . . . a great, new Ford Police Car option!

- Excellent stopping power even after repeated hard stops . . . less subject to fade.
- Improved straight-line stopping ability . . . less subject to pulling right or left.
- Increased brake lining life.
- More positive brake feel.
- Greater resistance to effects of water and dust.



1966 Ford & Fairlane Police Car Specifications

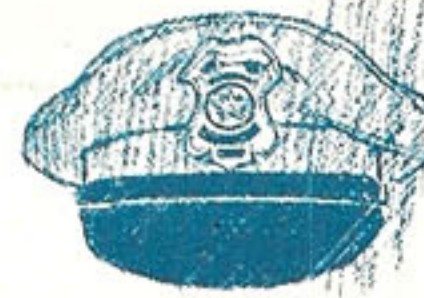

FORD CUSTOM FORD CUSTOM 500 AND WAGON

ENGINES: *New 360-hp Police Interceptor V-8* (Interceptor)—428-cu. in. displ.; 4.13" bore x 3.98" stroke; 10.5 to 1 comp. ratio; premium fuel; 4-barrel carburetor with automatic choke; copper-lead main and connecting rod bearings; 5-qt. oil capacity, incl. filter; dual exhausts.* *Special features include high-lift camshaft, solid lifters; high performance valve springs with solid retainers and internal dampers; precision-fitted exhaust valves with chromed stems; free-breathing air cleaner plus other hi-speed and long-life features.* *315-hp Thunderbird Special V-8* (Cruiser)—390-cu. in. displ.; 4.05" bore x 3.78" stroke; 10.5 to 1 comp. ratio; premium fuel; 4-barrel carburetor with automatic choke; free-turn valves with hydraulic lifters; precision-molded crankshaft; copper-lead main and connecting rod bearings; 5-qt. oil capacity, incl. filter; dual exhausts.* *275-hp Thunderbird V-8* (Guardian)—390-cu. in. displ.; 4.05" bore x 3.78" stroke; 9.5 to 1 comp. ratio; regular fuel; 2-barrel carburetor with automatic choke. Other specifications same as 315-hp V-8. *200-hp Challenger V-8* (Sentinel)—289-cu. in. displ.; 4.00" bore x 2.87" stroke; 9.3 to 1 comp. ratio; regular fuel; 2-barrel carburetor with automatic choke; free-turn valves with hydraulic lifters; precision-molded crankshaft; 5-qt. oil capacity, incl. filter; single exhaust. *150-hp Police Special Six* (Deputy)—240-cu. in. displ.; 4.00" bore x 3.18" stroke; 9.2 to 1 comp. ratio; precision-molded crankshaft with seven main bearings; gear-driven camshaft; regular fuel; single-barrel full economy carburetor with automatic choke; free-turn valves with hydraulic lifters; oil-bath air cleaner; disposable cartridge-type full-flow oil filter; 5-qt. oil capacity, incl. filter; single exhaust.

*Dual exhausts not included on wagons

CLUTCHES AND TRANSMISSIONS: *Clutches* in Police Packages have thick facings, and high-capacity pressure-plate springs. All are semi-centrifugal. Face diameter and frictional area is: 11.5" (130 sq. in.) with 428-cu. in. V-8, 11.0" (113.1 sq. in.) with 390 4V V-8, 10.4" (103.7 sq. in.) with 289-cu. in. V-8; heavy-duty 11" (113.1 sq. in.) with Six. Standard sedan clutch face diameter and frictional area: all same as above except 9½" (85.2 sq. in.) on Six. **3-Speed Manual Transmission** (standard; HD type in Deputy) is fully synchronized in all forward speeds, has hardened and shot-peened alloy-steel helical gears, and forged bronze synchronizers.† Police Package includes heavy-duty steering column. **4-Speed Manual Transmission** (optional for 428- and 390-cu. in. 4-barrel V-8's except wagon) is

fully synchronized in all forward speeds, floor-mounted shift lever. **Overdrive** (optional with 289 V-8 and 240 Six only) has 3-speed manual transmission plus automatic 4th gear that cuts in above 28 mph and cuts out below 21 mph (approx.), with downshift for passing by flooring accelerator. **Cruise-O-Matic Drive** (optional; HD type in Sentinel and Deputy) is 3-speed automatic transmission with two drive ranges: 3-speed range starting in low for all normal driving, or 2-speed range starting in intermediate for better control on slippery surfaces. **Interceptor Cruise-O-Matic** is specially calibrated for upshifts at higher rpm.

†Not available on 390 2V or 428 4V engine

REAR AXLE: *Police Package Heavy-Duty Axle* is semi-floating type with deep-offset hypoid gears and straddle-mounted drive pinion. Also included: fade-resistant brakes, higher capacity wheel bearings with larger diameter axle shafts. For axle ratios see page 6.

ELECTRICAL: 12-volt electrical system with 42-amp. alternator. Police Packages have 66-plate, 70 amp-hr heavy-duty battery. Standard sedan has 54-plate, 45 amp-hr battery. Weatherproof ignition system with Static-Ban constant-resistance wiring and air-cooled distributor points; 18-mm. Turbo-Action spark plugs; positive-engagement starter.

SUSPENSION: *Front*—Wide 62" tread; drag-strut, ball-joint type suspension system with mounting feature that allows slight rearward movement of front wheels to reduce effects of bumps and road faults. Ball joints packed with special 36,000-mile lubricant retained by full-life seals. Rubber-bushed stabilizer helps control sway on turns. Tapered roller wheel bearings with 30,000-mile check interval (repack as required). Specially calibrated shock absorbers with all-weather fluid for better year-round control. *Police Package* same as above with heavy-duty coil springs, shock absorbers and front stabilizer bar.

Rear—Wide 62" tread. Three-link coil spring system with long and short mounting-link arrangement to control dive and squat tendencies in braking and acceleration. Lateral track bar centers axle, resists body sway and roll on turns. All links and track bar rubber-bushed for smooth, quiet operation. Shock absorbers sea-leg-mounted to resist body side-shake, have all-weather fluid for more uniform ride control. *Police Packages* have heavy-duty coil springs and shock absorbers.

STEERING: Precision-control, low-friction recirculating-ball type steering gear with anti-friction bearings throughout plus high ratio for easier steering. Flexible coupling in steering shaft insulates steering wheel. Symmetrical linkage with nylon bearings in tie rod and pitman arm pivots packed with special 36,000-mile lubricant retained by full-life seals. Overall steering ratio 30.9 to 1; with power steering, 23 to 1.

Turning diameter approx. 41 feet.

BRAKES: Hydraulic, double-sealed, self-energizing design. Dash-mounted master cylinder. *Police Package Heavy-Duty Brakes* have 225-sq. in. riveted linings and specially grooved 11" dia. composite drums for maximum cooling and fade resistance. Manual or automatic adjustment. Standard sedan brakes have 204-sq. in. (225-sq. in. on wagons) riveted linings, air-grooved 11" composite drums and self-adjustment. Foot-operated parking brake with hand release under panel. New power disc front brakes optional.

TIRES: Low-profile design, 4-ply rating black tubeless tires with Tyrex rayon cord. Safety-type rims. Basic sizes: 7.35 x 15 (sedans); 8.15 x 15 (wagons). See your Ford Dealer for tire options.

DIMENSIONS: Overall length 210"; width 79.0"; height 55.6" (sedans), 56.7" (wagons); wheelbase 119"; treads 62" front and rear; fuel 25 gal. (sedans), 20 gal. (wagons); sedan trunk luggage vol. 19.1 cu. ft.; wagon cargo vol. 91.3 cu. ft.

FAIRLANE

ENGINES: *New 335-hp Thunderbird Special V-8* (Trooper)—390-cu. in. displ.; 4.05" bore x 3.78" stroke; 10.5 to 1 comp. ratio; premium fuel; 4-barrel carburetor with automatic choke; free-turn valves with hydraulic lifters; precision-molded crankshaft; copper-lead main and connecting rod bearings; 5-qt. oil capacity, incl. filter; dual exhausts. *New 265-hp Thunderbird V-8* (Pacer)—390-cu. in. displ.; 4.05" bore x 3.78" stroke; 9.5 to 1 comp. ratio; regular fuel; 2-barrel carburetor with automatic choke; free-turn valves with hydraulic lifters; precision-molded crankshaft; 5-qt. oil capacity, incl. filter; single exhaust. 275 hp with Cruise-O-Matic Drive. *200-hp Challenger V-8* (Ranger)—289-cu. in. displ.; 9.3 to 1 comp. ratio; regular fuel; 2-barrel carburetor with automatic choke; single exhaust. Other specifications same as 265-hp above. *120-hp Fairlane Six* (Sentry)—200-cu. in. displ., 3.68" bore x 3.13" stroke; 9.2 to 1 comp. ratio; regular fuel; single-venturi carburetor with automatic choke; precision-molded crankshaft with seven main bearings; free-turn valves with hydraulic lifters; 4.5-qt. oil capacity, incl. filter; single exhaust.

CLUTCHES AND TRANSMISSIONS: *Police Package Clutches* have same design as Ford Custom and Ford Custom 500. Six is heavy-duty 10.4" dia. (103.7 sq. in.), 289 V-8 is 10.0" (85.5 sq. in.), 390 2V V-8 is 11.0" (113.1 sq. in.), 390 4V V-8 is 11.5" (130.0 sq. in.). Standard sedan clutch for Six is semi-centrifugal design with 9" face dia. (70.6 sq. in.); V-8 clutch is semi-centrifugal, 10.0" dia., 85.5 sq. in. area. **3-Speed Manual Transmission:** (standard; HD type in Sentry)—Fully synchronized in all forward speeds. **4-Speed Manual Transmission:** (opt. with V-8's)—Floor shift, same

features as with Ford. **Overdrive:** (optional with 200-hp V-8)—3-speed manual transmission, plus automatic 4th gear. Similar to Ford. **Cruise-O-Matic Drive:** (opt. all engines)—Automatic 3-speed transmission. Same features as with Ford.

REAR AXLE: Semi-floating type with deep-offset hypoid gears. Straddle-mounted drive pinion. For axle ratios, see page 7.

ELECTRICAL: 12-volt system same as Ford models including 70 amp-hr heavy-duty battery, weather-proof ignition system, Turbo-Action spark plugs and positive-engagement starter.

SUSPENSION: *Front*—Angle-Poised ball-joint design with coil springs pivot-mounted on upper arms and shock absorbers internally mounted. Other features similar to Ford models. *Rear*—Wider and longer leaf springs with variable-rate characteristics. Asymmetrical design. Compression-type shackles. Spring tip liners between all but bottom leaves. Diagonally mounted shock absorbers. Front and rear shock absorbers have all-weather fluid for better control. *Police Package Suspension* includes heavy-duty springs and shock absorbers, front and rear, and stabilizer bar.

STEERING: Same type as Ford models. New overall steering ratio 29.4 to 1. Optional with power steering 21.6 to 1. Turning diameter 41.5 feet.

BRAKES: *Police Package Heavy-Duty Brakes* are self-adjusting with 10-inch drums. (Sentry has bonded or riveted linings—3.25 to 1 axle ratio.) Package brake area 182.1 sq. in. Standard sedan brake area 152.8 sq. in. Foot-operated parking brake with hand release under instrument panel. Power brakes optional; fade-resistant riveted brakes available for Sentry or Ranger (with 3.25 to 1 axle ratio).

TIRES: Low-profile design, 4-ply rating, blackwall, tubeless with Tyrex rayon cord, safety-type rims. Basic size, 6.95 x 14. See your Ford Dealer for tire options.

DIMENSIONS: Overall length 197"; width 74.7"; height 55"; wheelbase 116"; treads 58" front and rear; fuel 20 gal.; trunk luggage vol. 15.2 cu. ft.

PRICES: All power assists, optional equipment and accessories as well as some items illustrated or referred to as options, optional or available in this catalog are at extra cost. For the price of the model with the equipment you desire, see your Ford Dealer.

The illustrations and product information contained herein were current at the time this publication was approved for printing. However, in order to continue to offer the finest automotive products available, Ford Motor Company reserves the right to change specifications, designs, models or prices without notice and without liability for such changes.

PRODUCTS OF

