

1964

FORD POLICE CARS

and Emergency Vehicles

America's No.

1

Police Car

Here are the things that make

FORD THE NO. 1 NATIONAL FAVORITE IN POLICE VEHICLES

TOTAL PERFORMANCE

The finest in open competition, Ford includes its advanced Total Performance engineering features in every '64 police model.

BETTER-BUILT THROUGHOUT

'64 Fords are built throughout to the highest quality standards in Ford history. These cars have been refined and tested to the utmost.

EXTRA DEPENDABILITY

The '64 Fords were bred in car-punishing competition. They're more substantial than ever with extra muscle and over-all durability.

GREATER CONVENIENCE

Ford handling ease and riding comfort are better than ever. Wide-swing doors and handy controls give action-ready convenience.

LEAST MAINTENANCE

Ford-pioneered service-saving features help keep police cars in top condition, reduce shop downtime, keep maintenance costs low.

MOST MODELS

36 police models for '64, the most ever. Kit-priced Police Packages and recommended options are available for every duty range.

FORD CUSTOM AND FORD CUSTOM 500 SERIES POLICE CARS

Performance leaders in their field, Ford Police Cars offer new Custom and Custom 500 Series—20 cars in all—a choice of 2- or 4-door models in five power ranges: the 330-hp Police Interceptor, power-packed for outstanding acceleration and sustained high speeds of freeway patrol; the 300-hp Police Cruiser, V-8 powered for rugged highway operation; the Police Guardian, with a 250-hp V-8, excels in city and highway patrol; the Police Sentinel, tops in routine police work, has a new 195-hp V-8; the Police Deputy with the 138-hp Police Special Six for economical utility operation.

FORD GENERAL PURPOSE POLICE WAGONS

General police and emergency duty properly describes the ten new '64 Ford Police Wagons. Now available with any of the five kit-priced Ford Police Packages mentioned above, these versatile 6- or 9-passenger four-door models can be delivered with power and equipment options that "tailor" them for highway patrol, personnel transport, city cruising, rescue service, ambulance duty, or general utility assignment.

FAIRLANE SERIES POLICE CARS

Performance and economy highlight '64 Fairlane Police Car features. Lively power, big-car comfort and over-all economy are combined in a trim-size package. The six models—2- or 4-door—come in three power ranges: the Police Defender has a new, higher powered 195-hp V-8; the Police Ranger with a 164-hp V-8 is ideal for city cruising; the Police Sentry's 101-hp Fairlane Six gives top economy for utility duty.



1964 Police Interceptor with "Police-Designed" 330-hp Interceptor V-8

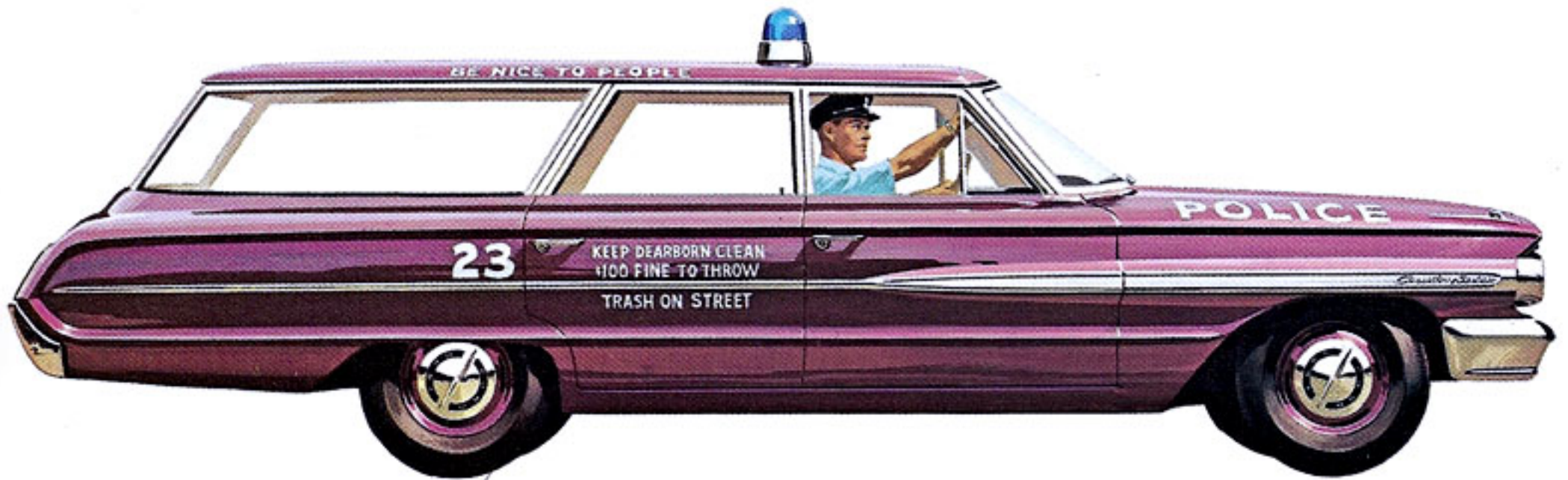

Ford Police Wagons (4-door, 6- or 9-pass.) now with choice of five power-equipment packages



Fairlane Police Defender with top-performance 195-hp Challenger V-8

'64 FORD POLICE INTERCEPTOR... TOTAL PERFORMANCE FOR MAXIMUM-DUTY USE



The '64 Ford Police Interceptor offers an outstanding example of Ford's Total Performance design concept in a modern police vehicle. Here is one of the finest maximum-duty police cars available today—proved in service, made even better with refinements perfected through experience in tough, open competition.

Special features tell the Police Interceptor story: the 4V/390 V-8 Police Interceptor engine—engineered for extremely fast acceleration—has the “extras” and built-in stamina needed for sustained high speed driving. Synchro-Smooth Drive, Ford's fully synchronized 3-speed manual transmission (no “crunch” in 1st) gives new shifting ease and durability. Optional floor shift all-synchronized 4-speed transmission, and Interceptor Cruise-O-Matic add extra performance and convenience.

The Police Interceptor is equipped with a Hi-Speed and Handling Package featuring heavy-duty springs, shock absorbers, and stabilizer bar for firm control and

high speed stability. Reinforced mono-pivot lower suspension arms add extra strength and durability. Large area, heavy-duty brakes give faster stops and resist brake fade with special lining material and groove-cooled drums. Police heavy-duty brakes are manually adjusted.

Roominess and driving comfort are important Police Interceptor benefits. Ford's full-width, heavy-duty front seat features extra head room, easy-operating adjustment with wear-resistant nylon track rollers, ideal-posture seat angle, and formed foam cushion padding (blanket foam rear). Both seats have the firm, equalized support of heavy-duty springs for comfort and durability.

The '64 Police Interceptor retains all previous Ford service-saving features and adds new durability through continuing vehicle refinements. The Police Interceptor is available as a complete vehicle in Ford Custom and Ford Custom 500 2-door and 4-door models with the power-equipment package specified on page 4.

POWERED BY THE MIGHTY INTERCEPTOR 4V/390 V-8

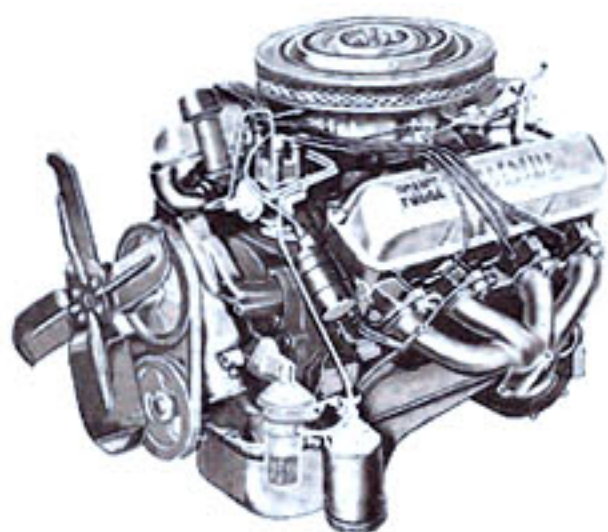

Displacement.....	390 cu. in.
Horsepower @ rpm.....	330 @ 5000
Torque (lbs-ft) @ rpm.....	427 @ 3200
Compression Ratio.....	10.1 to 1
Carburetor.....	4-venturi
Fuel.....	premium
Alternator—Single Belt Drive.....	42 amp.
Transmission—Axle Ratios:	
3- or 4-Speed Manual	
or Overdrive.....	3.50 to 1
(opt.).....	4.11 to 1*
Interceptor Cruise-O-Matic.....	3.00 to 1
(opt.).....	3.50 to 1

*With self-adjusting brakes

Designed for and sold to law enforcement agencies, this sturdy 330-hp powerplant is specially engineered to provide the soaring acceleration needed for modern highway pursuit, plus the heavy-duty durability that it takes to maintain reliable, sustained high speed operation. The Interceptor's ability to deliver top power results from an efficient, free-breathing induction system with special high-lift camshaft, solid valve lifters, special-alloy steel exhaust valves; and high-performance valve springs with solid retainers and internal damping springs. The direct-flow Super-Filter air cleaner and high velocity 4-venturi carburetor combine with low-restriction, header-type exhaust manifolds and

low back pressure mufflers to produce maximum power. 42-amp. alternator is included.

The Interceptor's inherent toughness and sustained high output abilities are based on Ford's Total Performance advanced design. Some of the durability and service-saving features are the extra-strong deep-block construction, short-stroke design, wedge-type combustion chambers, super-fitted light-alloy pistons, heavy-duty copper-lead alloy main and connecting rod bearings, high capacity cooling, 6,000-mile (or 6-month) Full-Flow oil filter, 36,000-mile (or 3-year) dry-type air cleaner, 36,000-mile (or 3-year) fuel filter, and 36,000-mile (or 2-year) coolant-antifreeze (available—factory installed).

EQUIPMENT

INCLUDED IN POLICE INTERCEPTOR PACKAGE:

- 330-hp Police Interceptor 4V/390 V-8
- 11-Inch Clutch
- 70 Amp-Hr HD Battery

PLUS:

- Manual 3-Speed Fully Synchronized Transmission
- Hi-Speed and Handling Package, Includes HD Springs with HD Extra-Control Shock Absorbers, Front and Rear, and HD Front Stabilizer Bar
- Reinforced Mono-Pivot Front Lower Suspension Arms
- HD Fade-Resistant Brakes with Riveted Linings, Manual Adjustment
- HD Maximum Head Room, Full Width Front Seat and HD Rear Seat with HD Springs and Padding (formed foam front and blanket foam rear padded cushions)
- Extra-Cooling Radiator
- Certified Calibration Speedometer (2 mph increments)
- HD Floor Mats, Black Rubber, Front and Rear

HIGHLY RECOMMENDED OPTIONS

- Interceptor Cruise-O-Matic Transmission (LPO)
- Front Seat Belts for Driver and Passenger (RPO)
- Padded Instrument Panel and Two Cushioned Sun Visors (RPO)
- 15" Tires and Wheels Required (LPO)

OTHER OPTIONS AVAILABLE FOR INTERCEPTOR AND CRUISER

RPO—Monthly Schedule Items

- Axle Ratios, Optional (see specifications)
- *Brakes, Power, Swift Sure
- *Clock, Electric, Self-Regulating
- Glass, Tinted (windshield or all around)
- Light Group, Courtesy—includes glove box light, ash tray light, trunk light, parking brake warning light, backup lights and courtesy light switches (for dome light) on all doors (except standard on front doors of Custom 500)
- *Mirror, Outside Rearview, Remote Control (left side)
- Paint, Two Tone
- *Radio AM, Push Button (all transistor)
- *Radio AM/FM, Push Button (all transistor)
- *Steering, Power, Master-Guide
- Transmission, 4-Speed Fully Synchronized, Floor-Mount Shift
- Transmission, Overdrive
- Windshield Wipers, Electric, 2-Speed and Windshield Washer

LPO—Limited Production Items

- Alternator Options—42-Amp. Semi-Pancake Type or 40-Amp. Regular Type or 60-Amp. HD Pancake Type with Built-In Silicon Rectifier, Dual Belt Drive
- Arm Rests, Rear (Custom)
- Ash Receptacle in Front Seat Back (Custom 4-door model)
- Fan, Extra-Cooling, Viscous Drive 1.25 Ratio (smaller water pump ratio, slip-disc fan slips at 1,600 rpm)
- Generator Option—40-Amp. HD Low Cut-In, Dual Belt Drive
- Lamps, Simultaneous-Flashing, Parking and Taillights
- *Lights, Backup
- Locking System, Single Key (one key for all locks in car)
- Mats, Floor, Color-Keyed Rubber, Front and Rear (Custom 500)
- *Mirror, Inside, Non-Glare
- *Mirror, Outside Body Mount (left or right side)
- Radio Noise Suppression Equipment
- Upholstery and Trim Set—Two-Tone Embossed Metallic Gold Beige with Medium Beige All-Vinyl
- Wheels, 15" and 6.70 x 15 or 7.10 x 15 4-pr. Tubeless or Tube-Type, or 7.10 x 15 6-pr. Tube-Type BSW Rayon Tires; also 6.70 x 15 or 7.10 x 15 4-pr. Tubeless BSW Nylon Tires
- Deletion of MagicAire Heater†

DSO—Special Order Items

- Alternator Options—60-Amp. HD Standard or EHD Types or 100-Amp. EHD with Built-In Silicon Rectifier
- *Belts, Front Seat Only, Driver or Passenger Conduit, 1 1/4" I.D. for Radio Cable
- Filters, Fuel, Ceramic Type
- Gauge, Charge Indicator
- Gauge, Oil Pressure
- Generator Options—40-Amp. Standard Type or 60-Amp. Heavy-Duty Type
- Light, Work (auxiliary lamp under instrument panel)
- Lights, Simultaneous Flashing—Red Grille Lights and Taillights
- Mirror, Door Outside-Mounted (left or right side)
- Mounting Base, Radio (in luggage compartment for radio equipment)
- Spare Tire Relocation (to accommodate radio equipment)
- Speedometer, Pace-Type with Special Needle Stop
- Spotlight—Cowl Mount without Mirror (specify red flashing or clear sealed beam)
- Spotlight—Door Mount with Mirror (specify red flashing or clear sealed beam)
- Suppression Spark Plugs with Non-Suppressed Ignition Wiring
- Throttle, Hand, Locking Type
- Window Regulators, Electric for Front Windows Only

Dealer Installed Items

- Antenna, Rear, Deluxe
- Extinguishers, Fire
- Guards, Bumper, Front and Rear
- Washer, Windshield
- Plus many other customary accessories

*Also dealer installed

†Heater is installed during production unless otherwise specified. If deleted, an appropriate price reduction is made.

Explanation of Terms

- RPO—Regular Production Option. Equipment advertised nationally and available without delay in production.
- LPO—Limited Production Option. Equipment generally used only by fleet and commercial accounts. Slight delays possible.
- DSO—Domestic Special Order. Specific procurement, with time necessary to fill order.

'64 POLICE CRUISER

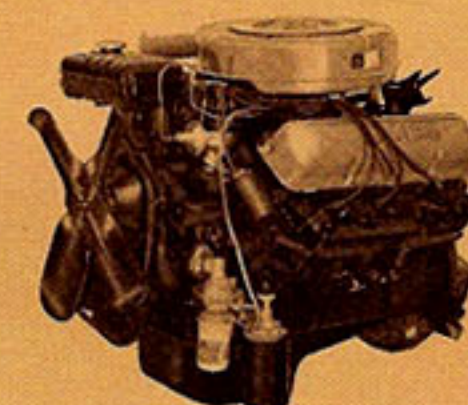

The Police Cruiser is recommended where high power is desirable, but Interceptor peak performance is not required. Both models are identical in everything except engines. The Cruiser is powered by the rugged 300-hp Thunderbird 4V/390 V-8 which has acceleration characteristics similar to the Interceptor's. Package equipment and most recommended options are same for both except for engine and regular Cruise-O-Matic transmission.

THUNDERBIRD 4V/390 V-8

Displacement.....	390 cu. in.
Horsepower @ rpm.....	300 @ 4600
Torque (lbs-ft) @ rpm.....	427 @ 2800
Compression Ratio.....	10.1 to 1
Carburetor.....	4-venturi
Fuel.....	premium
Transmission—Axle Ratios:	
3- or 4-Speed Manual	
or Overdrive.....	3.50 to 1
(opt.).....	3.89 to 1
Cruise-O-Matic.....	3.00 to 1
(opt.).....	3.50 to 1

FOR ANY ASSIGNMENT, THERE'S A BETTER-BUILT FORD CUSTOM OR FORD CUSTOM 500 TO DO THE JOB

OTHER OPTIONS AVAILABLE FOR
GUARDIAN, SENTINEL AND DEPUTY

'64 FORD POLICE GUARDIAN for highway or city patrol

The Police Guardian fills the requirements for all-around patrol duty, with emphasis on city or suburban cruising. There's plenty of power available with the lively new 250-hp Thunderbird V-8 engine, and it operates efficiently on regular fuel. In Ford Custom or Ford Custom 500 2-door and 4-door models.



EQUIPMENT INCLUDED IN POLICE GUARDIAN PACKAGE:

250-hp Thunderbird 4V/352 V-8
11-Inch Clutch
70 Amp-Hr HD Battery
Plus items below (same as in Interceptor Pkg.):
Manual 3-Speed Fully Synchronized Transmission
Hi-Speed and Handling Package, Includes HD Springs with HD Extra-Control Shock Absorbers, Front and Rear, and HD Front Stabilizer Bar
Reinforced Mono-Pivot Front Lower Suspension Arms
HD Fade-Resistant Brakes with Riveted Linings, Manual Adjustment
HD Maximum Head Room, Full Width Front Seat and HD Rear Seat with HD Springs and Padding (formed foam front and blanket foam rear padded cushions)
Extra-Cooling Radiator
Certified Calibration Speedometer (2 mph increments)
HD Floor Mats, Black Rubber, Front and Rear

HIGHLY RECOMMENDED OPTIONS

Cruise-O-Matic Transmission (RPO)
Padded Instrument Panel and Two Cushioned Sun Visors (RPO)
Front Seat Belts for Driver and Passenger (RPO)
15" Tires and Wheels (LPO)



THUNDERBIRD 4V/352 V-8

Displacement..... 352 cu. in.
Horsepower @ rpm..... 250 @ 4400
Torque (lbs-ft) @ rpm..... 352 @ 2800
Compression Ratio..... 9.3 to 1
Carburetor..... 4-venturi
Fuel..... regular

Transmission-Axle Ratios:
3-Speed Manual..... 3.25 to 1
(opt.)..... 3.50 to 1
Cruise-O-Matic..... 3.00 to 1

'64 FORD POLICE SENTINEL for medium duty economy

The Police Sentinel combines the advantage of lower first cost with thrifty V-8 operation. The Sentinel's new, higher powered 195-hp Challenger V-8 engine adds extra performance to handle emergency or routine patrol work. Regular fuel. Available in Ford Custom or Ford Custom 500 2-door and 4-door models.



EQUIPMENT INCLUDED IN POLICE SENTINEL PACKAGE:

195-hp Challenger 289 V-8
HD 10.4-Inch Clutch
65 Amp-Hr HD Battery
Plus items below (same as in Interceptor Pkg.):
Manual 3-Speed Fully Synchronized Transmission
Hi-Speed and Handling Package, Includes HD Springs with HD Extra-Control Shock Absorbers, Front and Rear, and HD Front Stabilizer Bar
Reinforced Mono-Pivot Front Lower Suspension Arms
HD Fade-Resistant Brakes with Riveted Linings, Manual Adjustment
HD Maximum Head Room, Full Width Front Seat and HD Rear Seat with HD Springs and Padding (formed foam front and blanket foam rear padded cushions)
Extra-Cooling Radiator
Certified Calibration Speedometer (2 mph increments)
HD Floor Mats, Black Rubber, Front and Rear

HIGHLY RECOMMENDED OPTIONS

Cruise-O-Matic Transmission (RPO)
Padded Instrument Panel and Two Cushioned Sun Visors (RPO)
Front Seat Belts for Driver and Passenger (RPO)
15" Tires and Wheels (LPO)

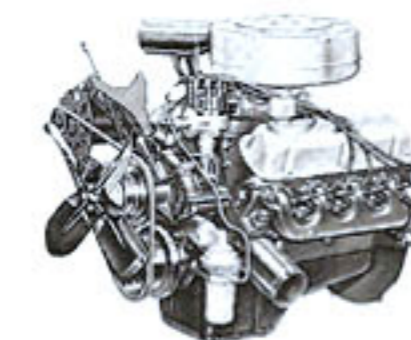

CHALLENGER 289 V-8

Displacement..... 289 cu. in.
Horsepower @ rpm..... 195 @ 4400
Torque (lbs-ft) @ rpm..... 282 @ 2400
Compression Ratio..... 9.0 to 1
Carburetor..... 2-venturi
Fuel..... regular

Transmission-Axle Ratios:
3-Speed Manual..... 3.25 to 1
(opt.)..... 3.89 to 1
Overdrive..... 3.50 to 1
Cruise-O-Matic..... 3.25 to 1
(opt.)..... 3.50 to 1

'64 FORD POLICE DEPUTY for general utility duty

The Police Deputy is especially efficient in city traffic patrol or utility assignments. Its economical 138-hp Police Special Six engine provides adequate power for normal cruising with extra reserve for quick sprints. Regular fuel. Available in Ford Custom or Ford Custom 500 2-door and 4-door models.



EQUIPMENT INCLUDED IN POLICE DEPUTY PACKAGE:

138-hp Police Special Six
HD 11-Inch Clutch
70 Amp-Hr Battery
HD Wear-Resistant Brakes with Bonded Linings, Manual Adjustment
Plus items below (same as in Interceptor Pkg.):
Manual 3-Speed Fully Synchronized Transmission
Hi-Speed and Handling Package, Includes HD Springs with HD Extra-Control Shock Absorbers, Front and Rear, and HD Front Stabilizer Bar
Reinforced Mono-Pivot Front Lower Suspension Arms
HD Maximum Head Room, Full Width Front Seat and HD Rear Seat with HD Springs and Padding (formed foam front and blanket foam rear padded cushions)
Extra-Cooling Radiator
Certified Calibration Speedometer (2 mph increments)
HD Floor Mats, Black Rubber, Front and Rear

HIGHLY RECOMMENDED OPTIONS

Cruise-O-Matic Transmission (RPO)
Padded Instrument Panel and Two Cushioned Sun Visors (RPO)
Front Seat Belts for Driver and Passenger (RPO)
15" Tires and Wheels (LPO)



POLICE SPECIAL SIX

Displacement..... 223 cu. in.
Horsepower @ rpm..... 138 @ 4200
Torque (lbs-ft) @ rpm..... 203 @ 2200
Compression Ratio..... 8.4 to 1
Carburetor..... 1-venturi
Fuel..... regular

Transmission-Axle Ratios:
3-Speed Manual..... 3.50 to 1
(opt.)..... 3.89 to 1
Overdrive..... 3.89 to 1
Cruise-O-Matic..... 3.50 to 1

RPO—Monthly Schedule Items
Axle Ratios, Optional (see specifications)
*Brakes, Power, Swift Sure
*Clock, Electric, Self-Regulating
Glass, Tinted (windshield or all-around)
Light Group, Courtesy—includes glove box light, ash tray light, trunk light, parking brake warning light, backup lights and courtesy light switches (for dome light) on all doors (except standard on front doors of Custom 500)
*Mirror, Outside Rearview, Remote Control (left side) Paint, Two-Tone
*Radio AM, Push Button (all-transistor)
*Radio AM/FM, Push Button (all-transistor)
*Steering, Power Master-Guide
Transmission, Overdrive for Six and 289 V-8 Engines (not available with HD clutch)
Tires—Five 7.50 x 14 4-pr. Tubeless (for Custom Deputy 2- and 4-dr., and Sentinel 2-dr. Sedans without power assists)
Windshield Wipers, Electric, 2-Speed and Windshield Washer

LPO—Limited Production Options
Alternator Options—42-Amp. Semi-Pancake Type or 40-Amp. Regular Type or 60-Amp. HD Pancake Type with Built-In Silicon Rectifier, Dual Belt Drive Arm Rests, Rear (Custom)
Ash Receptacle in Front Seat Back (Custom 4-dr. model)
Fan, Extra-Cooling, Viscous Drive 1.25 Ratio (smaller water pump ratio, slip-disc fan slips at 1,600 rpm)—for 352 V-8 only
Fan, Five-Blade (Six and 289 V-8)
Generator Option—40-Amp. HD Low Cut-In (dual belt drive with 352 and 289 V-8's; choice of single or dual belt drive with Six)
Lamps, Simultaneous Flashing, Parking and Taillights
*Lights, Backup
Locking System, Single-Key (one key for all locks in car)
Mats, Floor, Color-Keyed Rubber, Front and Rear (Custom 500)
*Mirror, Inside, Non-Glare
*Mirror, Outside Body Mount (left or right side)
Radio Noise Suppression Equipment
Upholstery and Trim Set—Two-Tone Embossed Metallic Gold Beige with Medium Beige All-Vinyl
Wheels, 15" and 6.70 x 15 or 7.10 x 15 4-pr. Tubeless or Tube-Type, or 7.10 x 15 6-pr. Tube-Type BSW Rayon Tires; also 6.70 x 15 or 7.10 x 15 4-pr. Tubeless BSW Nylon Tires
Deletion of MagicAire Heater

DSO—Special Order Items
Alternator Options—60-Amp. HD Standard or EHD Types or 100 Amp. EHD with Built-In Silicon Rectifier
*Belts, Front Seat Only, Driver or Passenger
Conduit, 1 1/4" I.D. for Radio Cable
Filters, Fuel, Ceramic
Gauge, Charge Indicator
Gauge, Oil Pressure
Generator Options—40-Amp. Standard Type or 60-Amp. Heavy-Duty Type
Light, Work (auxiliary lamp under instrument panel)
Lights, Simultaneous Flashing—Red Grille Lights and Taillights
Mirror, Outside Mounted, Door (left or right side)
Mounting Base, Radio (in luggage compartment for radio equipment)
Spare Tire Relocation (to accommodate radio equipment)
Speedometer, Pace-Type with Special Needle Stop
Spotlight—Cowl Mount without Mirror (specify red flashing or clear sealed beam)
Spotlight—Door Mount with Mirror (specify red flashing or clear sealed beam)
Suppression Spark Plugs with Non-Suppression Ignition Wiring
Throttle, Hand, Locking Type
Window Regulators, Electric for Front Windows Only

DEALER INSTALLED ITEMS
Antenna, Rear, Deluxe
Extinguishers, Fire
Guards, Bumper, Front and Rear
Washer, Windshield
Plus many other customary accessories

*Also dealer installed
†Heater is installed during production unless otherwise specified. If deleted, an appropriate price reduction is made.

EXPLANATION OF TERMS
RPO—Regular Production Option. Equipment advertised nationally and available without delay in production.
LPO—Limited Production Option. Equipment generally used only by fleet and commercial accounts. Slight delays possible.
DSO—Domestic Special Order. Specific procurement, with time necessary to fill order.

DUTY-TESTED FEATURES MAKE THE '64 FORD AMERICA'S NO. 1 POLICE CAR

HERE ARE SOME MAJOR REASONS WHY FORD LEADS IN CONVENIENCE, SAFETY, DEPENDABILITY



Wide Entrance Front Doors swing wide for fast-moving exit and entry. Crank-operated vent windows position easily, seal tightly against wind noise and weather.



Posture-Perfect Seats are scientifically angled at 23° for best riding comfort. Heavy-duty front seat has extra-low tracks to give maximum head room.

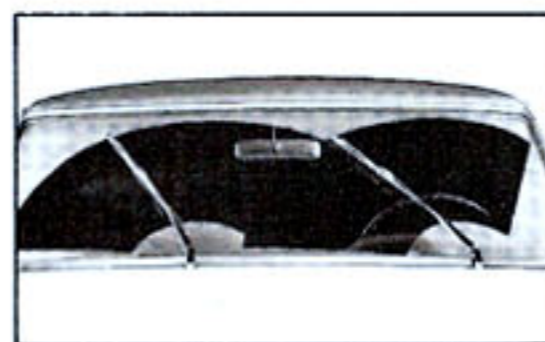

Wide Sweep Visibility with tandem-action single-speed electric windshield wipers. Constant-speed wiping with no center blind spot for greater all-weather safety.



Lifeguard Steering Wheel has recessed hub and even-spaced spokes to equalize impact pressures for more protection against chest injury in event of collision.

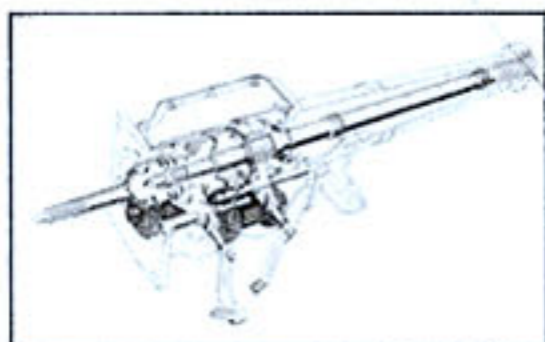

Synchro-Smooth Manual Transmission is fully synchronized in all three forward speeds to permit smooth shifting, even in low gear. Shift lever is column-mounted.



Foot-Operated Parking Brake for quick, step-on operation. Leaves hands free for fast stop-and-exit action. Brake release control is under panel at left side.



Safety-Yoke Door Latches resist pull-apart forces, close easily and securely. Self-centering latch yoke action helps keep doors aligned, resists rattles.

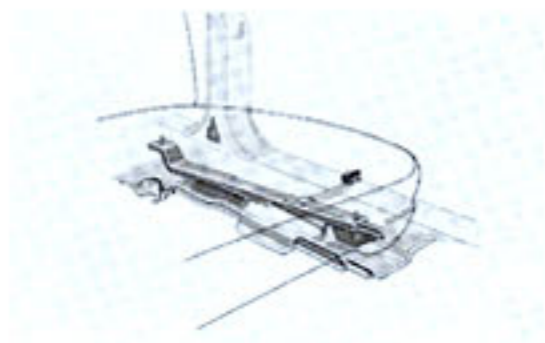

Safety Seat Track heavy steel construction resists pull-apart for extra safety. Adjusts easily a full 5 inches fore and aft on wear-resistant nylon rollers.

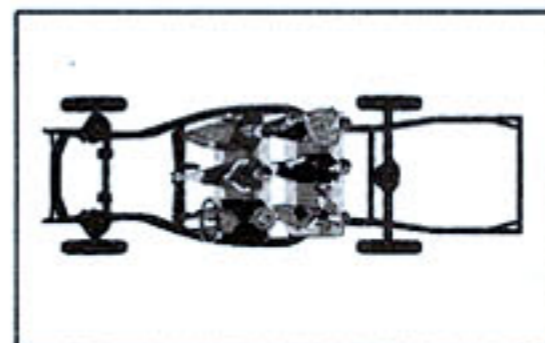

Safety-Contoured Frame encloses passenger floor area within strong box-section frame rails to help give extra protection in event of side impact.

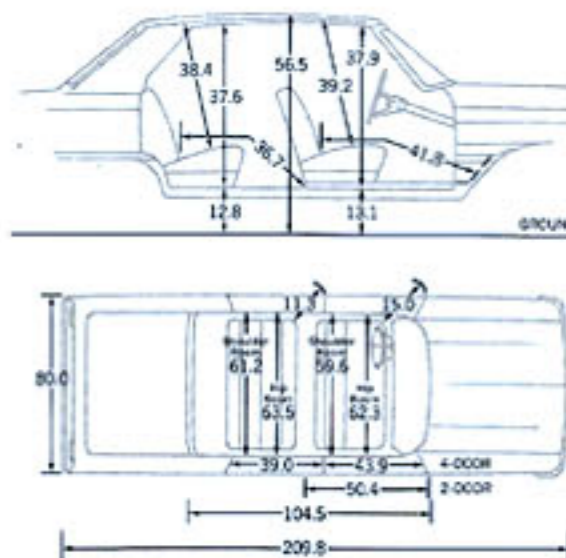
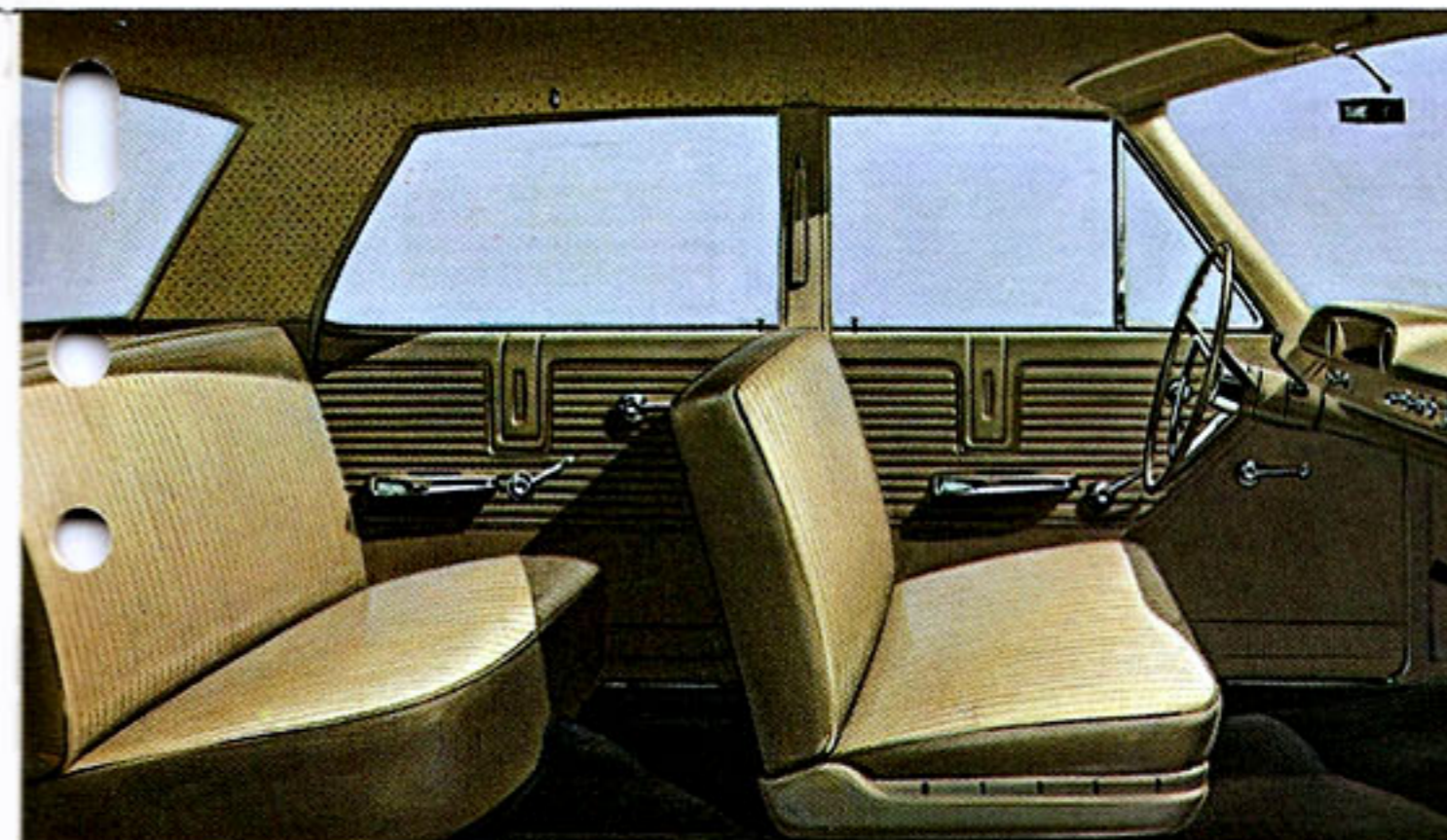

COMFORTABLE FORD "INNER-SPACE" EASES LONG PATROL FATIGUE

Ford Police Car interiors provide the alert seating comfort and practical utility that's important in all-around police work. Heavy-duty seats are scientifically angled for best seating support in long hours of cruising. They have heavy-duty springs and foam padding to make them both comfortable and durable. Upholstery is long-wearing nylon and cloth or optional heavy-duty all-vinyl. All-vinyl headlining and door panel covering are easy to keep clean. Floor mats are heavy-duty black rubber, front and rear.

SPECIAL PLUS FEATURES

- ★ Full width front seat adjusts easily a full 5 inches on long-lasting, low-friction nylon rollers.
- ★ Low-profile front seat track construction provides maximum head room clearance.
- ★ Lower, narrower front floor tunnel gives extra front foot room space, more convenience.

FORD CUSTOM AND FORD CUSTOM 500 HEAVY-DUTY POLICE EQUIPMENT

ALTERNATOR-GENERATOR SELECTION

Generating systems must supply the total electrical load requirement for average driving speed plus sufficient output to charge the battery. By adding appropriate constant and intermittent load items from the table below, you can estimate the total load for your vehicle. In totaling intermittent loads, use only a percentage of each load figure that represents its normal time in use (full-time 100%, 1/2-time 50%, etc.). System output characteristics should closely match vehicle operation. Curves at right show alternator and generator cut-in or low-speed characteristics, performance curve slope, and rated current output as related to vehicle speed.

AVERAGE AMPERE-DRAW FOR ELECTRICAL EQUIPMENT

Constant-Load Equipment:	2-Way Radio (stand-by)	Glove Box Light	0.3
Ignition & Gauges	Tube-Type	Work Light	0.7
Lighting Draw (incl. lamps turned on by headlamp sw. Select one, Low or High)	Full Transistor	Wipers, 1-Speed	2.3
"Low Beam"	Intermittent-Load Equipment:	Wipers, 2-Speed (low)	3.0
"High Beam"	Turn Signals	Wipers, 2-Speed (high)	2.2
Heater Blower	Spotlight	Entertainment Radio	1.2
	Backup Lights	Power Windows (each)	17.0
		Police Roof Flasher	8.0
		Siren	70.0

Heavy-Duty Battery, included in all Ford police packages, provides additional capacity for extra electrical load requirements. 70 or 65 amp-hr as specified.

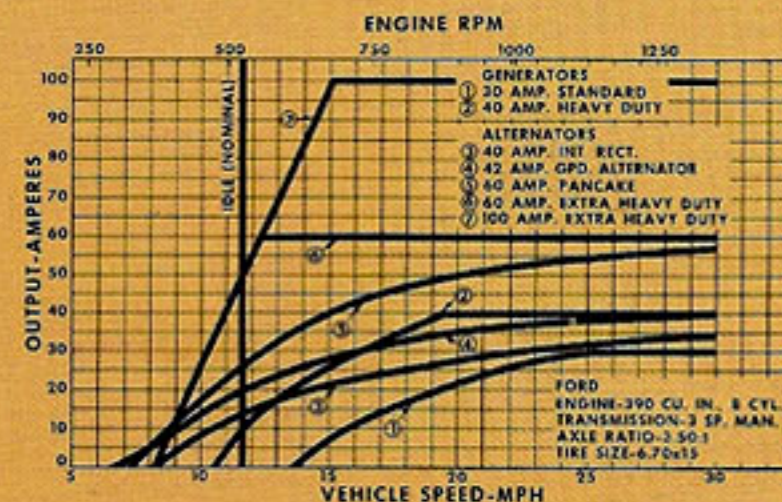

Heavy-Duty Fade-Resistant Brakes with manual adjustment feature 234-sq. in. riveted linings and groove-cooled drums for consistent, high speed braking. Heavy-duty bonded brakes are also available.

15-Inch Wheels and Tires run cooler at high speeds, increase fuel economy, 6.70 or 7.10 tires on 5 1/2" rims reduce heat blowout problems, increase tire life.

Hi-Speed and Handling Package helps to give better stability and driving control, surer handling at pursuit speeds, less sway on curves. Heavy-duty suspension system lessens "bottoming," lasts longer in police duty. Includes reinforced mono-pivot lower front suspension arms, heavy-duty front coil springs and stabilizer bar, extra-capacity rear leaf springs, and specially calibrated, heavy-duty shock absorbers.

SERVICE-SAVING FEATURES SAVE SHOP TIME

- ★ 36,000-Mile (or 3-year, whichever comes first) Chassis Lube Interval covers steering linkage, universal joints, and front suspension system. Front wheel bearings are checked at 24,000-mile intervals and repacked as required.
- ★ 6,000-Mile (or 6-month) Oil and Oil Filter Change* schedule saves on oil, oil filter and shop time costs.
- ★ 36,000-Mile (or 2-year) Coolant-Antifreeze is available factory-installed, eliminates seasonal changes, flushing.
- ★ Double-Wrapped Aluminized Muffler gives longer life than uncoated types.

- ★ 36,000-Mile (or 3-year) Fuel Filter Element* helps keep carburetor clean, reduces flooding or clogging.
- ★ 36,000-Mile (or 3-year) Air Cleaner (V-8's) has dry-type replaceable element. Six has permanent oil-bath type.
- ★ No-Wax Diamond Lustre Finish holds its hard-gloss enamel brilliance with routine cleaning, keeps new looking longer.
- ★ Long-Life Lamp Bulbs lower the costs of frequent parking and taillight bulb

replacement and reduce the hazards of unnoticed burn-outs.

- ★ Rust-Resistant Body includes Zinclad rocker panels and zinc primer protected areas of body and fenders.
- ★ No 1,000-Mile Break-In Oil Change—Ford's regular 6,000-mile oil change and twice-a-year checkup are all that's required.*

*Oil and oil filter change each 3,000 miles and 24,000-mile fuel filter replacement recommended for vehicles in prolonged slow-speed and/or extended idling operations.

'64 FORD POLICE WAGONS OFFER FIVE COMPLETE EQUIPMENT PACKAGES

FORD POLICE WAGON OPTIONS

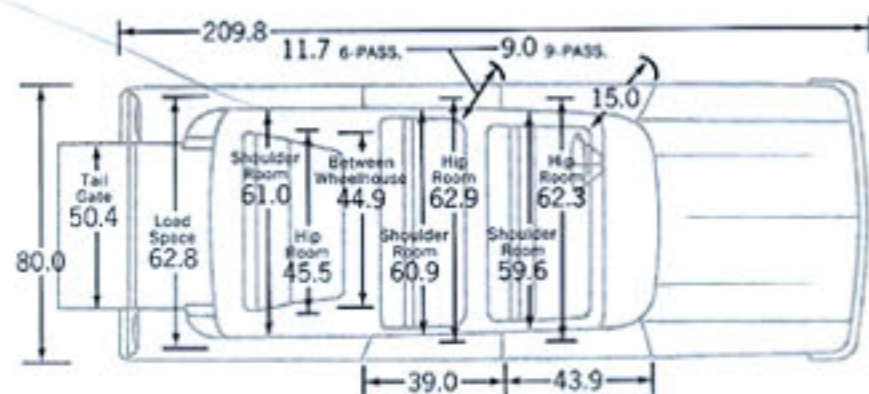
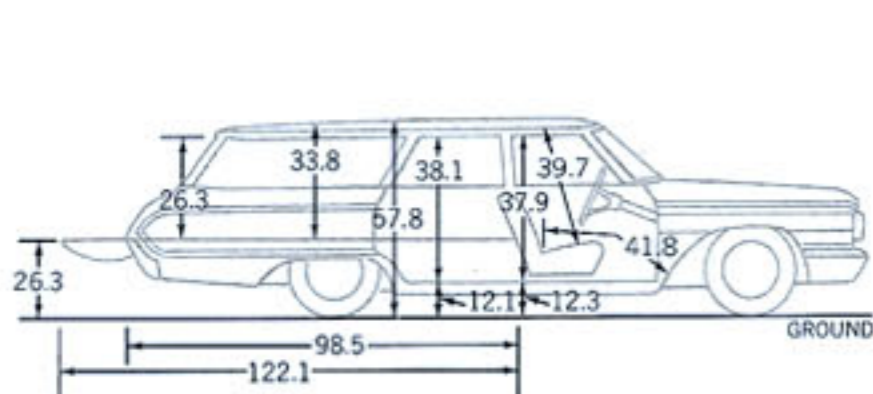

Ford Police Wagons are adaptable to practically any kind of police work from high speed pursuit to rescue or utility service. The roomy rear deck and fold-down seat provide quick convertibility from regular 6-passenger seating, to load-carrying space large enough for two regulation-size stretchers or other emergency-duty equipment. A 9-passenger model with front-facing 3rd seat is also available.

The roll-down tailgate window gives easy access to the rear deck and provides controlled, straight-through ventilation. A convenient, power-operated tailgate window is optional on 6-passenger wagon (std. on 9-pass.). All-vinyl upholstery and interior trim are long-wearing and easy to clean. The heavy-duty front seat has firm support springs and foam cushion padding for comfort and durability, low-profile tracks give maximum head room.

The Hi-Speed and Handling Package helps Ford Police Wagons hold the road better and maneuver more easily. Generous-size brakes give safer stops.

'64 Ford Police Wagons are now available with any of the five kit-priced equipment packages shown on pages 4 through 7.

HIGHLY RECOMMENDED OPTIONS

- Cruise-O-Matic Transmission (see RPO and LPO)
- Padded Instrument Panel and Two Cushioned Sun Visors (RPO)
- Front Seat Belts for Driver and Passenger (RPO)
- 15" Tires and Wheels (LPO) (Required with Interceptor)

RPO—MONTHLY SCHEDULE ITEMS

- Axle Ratios, Optional (see chart)
- *Brakes, Power, Swift Sure
- *Clock, Electric, Self-Regulating
- Glass, Tinted (windshield or all around)
- Light Group, Courtesy—includes glove box light, ash tray light, cargo area light, parking brake warning light, backup lights and courtesy light switches (for dome light) on rear doors (standard on front doors)
- *Mirror, Outside Rearview, Remote Control (left side)
- Paint, Two-Tone
- *Radio AM, Push Button (all transistor)
- *Radio AM/FM, Push Button (all transistor)
- *Steering, Power, Master-Guide
- Transmission, Overdrive for Six and 289 or 390 V-8 Engines (not available with HD clutch)
- Transmission, Cruise-O-Matic (all packages, except for Interceptor V-8 see LPO)
- Window, Tailgate, Power Operated
- Windshield Wipers, Electric, 2-Speed and Windshield Washer

LPO—LIMITED PRODUCTION ITEMS

- Alternator Options—42-Amp. Semi-Pancake Type or 40-Amp. Regular Type or 60-Amp. HD Pancake Type with Built-In Silicon Rectifier, Dual Belt Drive
- Fan, Extra-Cooling, Viscous Drive 1.25 Ratio (smaller water pump ratio, slip-disc fan slips at 1,600 rpm)—for 352 and 390 V-8's only
- Fan, Five-Blade (Six and 289 V-8)
- Generator Option—40-Amp. HD Low Cut-In (single or dual belt drive with Six; dual belt drive only on other engines)
- Lights, Simultaneous Flashing, Parking and Taillights
- *Lights, Backup
- Locking System, Single-Key (one key for all locks in wagon)
- *Mirror, Inside, Non-Glare
- *Mirror, Outside Body Mount, Full-View (left or right side)
- Radio Noise Suppression Equipment

Transmission, Interceptor Cruise-O-Matic (recommended for Interceptor 4V/390 V-8)

Wheels, 15" and 7.10 x 15 4-pr. BSW Rayon or Nylon Tubeless, or 7.10 x 15 4- or 6-pr. BSW Rayon Tube-Type Tires

Deletion of MagicAire Heater

DSO—SPECIAL ORDER ITEMS

- Alternator Options—60-Amp. HD Standard or EHD Types or 100-Amp. EHD with Built-In Silicon Rectifier
- *Belts, Front Seat Only, Driver or Passenger Filters, Fuel, Ceramic Type
- Gauge, Charge Indicator
- Gauge, Oil Pressure
- Generator Options—40-Amp. Standard Type or 60-Amp. Heavy-Duty Type
- Light, Work (auxiliary lamp under instrument panel)
- Lights, Simultaneous Flashing—Red Grille Lights and Taillights
- Mirror, Outside Mounted, Door (left or right side)
- Speedometer, Pace-Type with Special Needle Stop
- Spotlight—Cowl Mount without Mirror (specify red flashing or clear sealed beam)
- Spotlight—Door Mount with Mirror (specify red flashing or clear sealed beam)
- Suppression Spark Plugs with Non-Suppression Ignition Wiring
- Throttle, Hand, Locking Type
- Window Regulators, Electric for Front Windows Only

DEALER INSTALLED ITEMS

- Deflector, Mud and Stone
 - Extinguishers, Fire
 - Guards, Front Bumper
 - Mat, Cargo Deck, Rubber
 - Washer, Windshield
 - Plus many other customary accessories
- *Also dealer installed
†Heater is installed during production unless otherwise specified. If deleted, an appropriate price reduction is made.

EXPLANATION OF TERMS

- RPO** Regular Production Option. Equipment advertised nationally and available without delay in production.
- LPO** Limited Production Option. Equipment generally used only by fleet and commercial accounts. Slight delays possible.
- DSO** Domestic Special Order. Specific procurement, with time necessary to fill order.

PICK THE PACKAGE THAT FITS YOUR JOB



PACKAGE	INTERCEPTOR	CRUISER	GUARDIAN	SENTINEL	DEPUTY
ENGINES	Interceptor 4V/390 V-8	Thunderbird 4V/390 V-8	Thunderbird 4V/352 V-8	Challenger 289 V-8	Police Special Six
Displacement (cu. in.)	390	390	352	289	223
Horsepower @ rpm	330 @ 5000	300 @ 4600	250 @ 4400	195 @ 4400	138 @ 4200
Torque (lbs-ft) @ rpm	427 @ 3200	427 @ 2800	352 @ 2800	282 @ 2400	203 @ 2200
Compression Ratio (to 1)	10.1	10.1	9.3	9.0	8.4
Alternator (single belt drive)	42 amp.	—	—	—	—
Transmission	3-Speed	3-Speed	3-Speed	3-Speed	3-Speed
Clutch (dia. in.)	11	11	11	HD 10.4	HD 11
Battery (amp-hr)	70 HD	70 HD	70 HD	65 HD	70 HD
TRANSMISSION-AXLE RATIOS					
3-Speed Manual (std.)	3.50 (4.11*)†	3.50 (3.89)†	3.25 (3.50)†	3.25 (3.89)†	3.50 (3.89)†
Overdrive (opt.)	3.50 (4.11*)†	3.50 (3.89)†	—	3.50	3.89
Cruise-O-Matic (opt.)	3.00 (3.50)†	3.00 (3.50)†	3.00	3.25 (3.50)†	3.50

*With self-adjusting brakes

†Optional ratio shown in parenthesis

ALSO INCLUDED WITH EACH PACKAGE ABOVE:

- Hi-Speed and Handling Package, includes HD Springs and Shock Absorbers, Front and Rear, HD Stabilizer Bar
- Reinforced Mono-Pivot Front Lower Suspension Arms
- Fade-Resistant Brakes with Riveted Linings, Manual Adjustment (except with 4.11 axle ratio); Bonded Linings on Deputy

- HD Maximum Head Room, Full Width Front Seat with HD Springs and Formed Foam Cushion Padding
- Extra-Cooling Radiator
- Certified Calibration Speedometer (2 mph increments)
- HD Front Floor Mat, Black Rubber



LARGE CAPACITY LOADSPACE

The '64 Ford Police Wagon has a maximum loadspace of more than 99 cubic feet. When the second seat is folded, the flat, level rear deck measures over 5 feet wide and more than 8 feet long, with tailgate up. Over-all load-carrying length is over 10 feet with tailgate down. The tailgate opening is over 4 feet wide and more than 2 feet high to make loading and unloading easy. Dimensions shown on facing page give exact wagon measurement details.

SPECIAL WAGON CONVERSION OPTIONS



Conversion by Shop of Siebert Associates Inc., Whitehouse, Ohio (Aristocrat model shown)



Conversion by Automotive Conversion Corp., Birmingham, Michigan

The Ford Police Wagon can be modified for specialized ambulance, auxiliary fire fighting, rescue and other emergency vehicle uses by body shops specializing in this work. These conversion options are fully tested and proved, and relatively inexpensive. The side-opening rear door shown, hinged at the left for safer curb loading, may be special-ordered from the body builder. Complete details and conversion options data are available from your Ford Dealer or a custom conversion specialist.

1964 FAIRLANE SERIES . . . TOTAL PERFORMANCE WITH PRACTICAL ECONOMY

OTHER OPTIONS AVAILABLE FOR DEFENDER, RANGER, SENTRY



1964 Fairlane Defender

'64 Fairlane Police Cars mark a new era in police vehicles. These trim, agile cars demonstrate their total performance heritage by delivering a well-engineered combination of sparkling road speeds, steady roadability, alert riding comfort and solid, quiet construction—all with surprisingly low initial cost and excellent operating economy.

The Police Defender has a new higher powered 195-hp Challenger 289 V-8 engine for improved acceleration and top performance. The Police Ranger also has more power than before with its 164-hp Challenger 260 V-8. The Police Sentry offers the sturdy 101-hp Fairlane Six for light patrol or general utility operation. A 116-hp Fairlane Six with Fordomatic transmission is also available. All Fairlane Police Cars are available in 2- and 4-door models.

'64 FAIRLANE POLICE DEFENDER

CHALLENGER 289 V-8

Displacement 289 cu. in.
Horsepower @ rpm 195 @ 4400
Torque (lbs-ft) @ rpm 282 @ 2400
Compression Ratio 9.0 to 1
Carburetor 2-venturi
Fuel regular
Transmission-Axle Ratios:
3- or 4-Speed Manual 3.50 to 1
(opt.) 3.25 to 1
Cruise-O-Matic 3.00 to 1
(opt.) 3.25 to 1

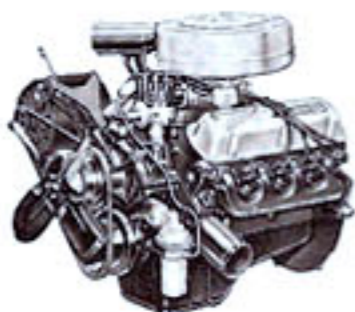

EQUIPMENT INCLUDED IN POLICE DEFENDER PACKAGE:

195-hp Challenger 289 V-8
HD 10.4-Inch Clutch
55 Amp-Hr Battery

Plus the following:

Manual 3-Speed Fully Synchronized Transmission—
3.50 to 1 Rear Axle Ratio
HD Springs and HD Shock Absorbers, Front and Rear
HD Fade-Resistant Brakes with Riveted Linings,
Manual Adjustment
HD Front and Rear Seats with HD Springs and Padding
(foam in cushions)
Extra-Cooling Radiator
Certified Calibration Speedometer (2 mph increments)
HD Floor Mats, Black Rubber, Front and Rear

Highly Recommended Options

Cruise-O-Matic Transmission (RPO)
Padded Instrument Panel and Two Cushioned Sun Visors (RPO)
Front Seat Belts for Driver and Passenger (RPO)

'64 FAIRLANE POLICE RANGER

CHALLENGER 260 V-8

Displacement 260 cu. in.
Horsepower @ rpm 164 @ 4400
Torque (lbs-ft) @ rpm 258 @ 2200
Compression Ratio 8.8 to 1
Carburetor 2-venturi
Fuel regular
Transmission-Axle Ratios:
3-Speed Manual 3.50 to 1
Overdrive 3.50 to 1
Fordomatic 3.50 to 1
(opt.) 3.25 to 1



EQUIPMENT INCLUDED IN POLICE RANGER PACKAGE:

164-hp Challenger 260 V-8
HD 10.4-Inch Clutch
55 Amp-Hr Battery

Plus the following:

Manual 3-Speed Fully Synchronized Transmission—
3.50 to 1 Rear Axle Ratio
HD Springs and HD Shock Absorbers, Front and Rear
HD Fade-Resistant Brakes with Riveted Linings,
Manual Adjustment
HD Front and Rear Seats with HD Springs and Padding
(foam in cushions)
Extra-Cooling Radiator
Certified Calibration Speedometer (2 mph increments)
HD Floor Mats, Black Rubber, Front and Rear

Highly Recommended Options

Fordomatic Transmission (RPO)
Padded Instrument Panel and Two Cushioned Sun Visors (RPO)
Front Seat Belts for Driver and Passenger (RPO)

'64 FAIRLANE POLICE SENTRY

FAIRLANE SIX	Std. w/3-Spd.	Opt. w/Fordo.
Displacement (cu. in.)	170	200
Horsepower @ rpm	101 @ 4400	116 @ 4400
Torque (lbs-ft) @ rpm	156 @ 2400	185 @ 2400
Compression Ratio	8.7 to 1	
Carburetor	1-venturi	regular
Fuel	regular	
Transmission-Axle Ratios: 3-Speed Manual (101-hp Six only)	3.25 to 1 (opt.) 3.50 to 1	
Fordomatic (116-hp Six only)		3.25 to 1 (opt.) 3.50 to 1



EQUIPMENT INCLUDED IN POLICE SENTRY PACKAGE:

101-hp Fairlane Six (170 cu. in.)
HD 9½-Inch Clutch
55 Amp-Hr HD Battery

Plus the following:

Manual 3-Speed Fully Synchronized Transmission—
3.25 to 1 Rear Axle Ratio
HD Springs and HD Shock Absorbers, Front and Rear
HD Wear-Resistant Brakes with Bonded Linings,
Manual Adjustment (3.25 to 1 rear axle ratio)[‡]
HD Front and Rear Seats with HD Springs and Padding
(foam in cushions)
Extra-Cooling Radiator
Certified Calibration Speedometer (2 mph increments)
HD Floor Mats, Black Rubber, Front and Rear

[‡]Fade-resistant brakes also available (see LPO)

Highly Recommended Options

116-hp Fairlane Six (200 cu. in.) with Fordomatic
Transmission (RPO)
Padded Instrument Panel and Two Cushioned Sun Visors (RPO)
Front Seat Belts for Driver and Passenger (RPO)

RPO—Monthly Schedule Items

Axle Ratios, Optional (see specifications)
Battery, 65 Amp-Hr HD
*Brakes, Power, Swift Sure
Glass, Tinted (windshield only or all around)
Light Group, Courtesy—includes ash tray, glove box,
trunk, work and backup lights; front and rear
courtesy switches
Paint, Two-Tone
*Radio AM, Push Button (all transistor)
*Steering, Power Master-Guide (except Six with
manual transmission)
Tires, 7.00 x 14 4- or 6-pr. BSW Rayon Tubeless
Transmission, 4-Speed Fully Synchronized, Floor-
Mounted Shift (for 289 V-8 only)
Transmission, Overdrive (for 260 V-8 only)
*Wheel Covers, Full Stainless Steel
Windshield Wipers, Electric, 2-Speed and Wind-
shield Washer

LPO—Limited Production Items

Alternator Options—42-Amp. Semi-Pancake Type or
40-Amp. Regular Type or 60-Amp. HD Pancake
Type with Built-In Silicon Rectifier, Dual Belt Drive
Arm Rests, Rear
Ash Receptacle in Front Seat Back (4-door model)
Brakes, HD Wear-Resistant with Bonded Linings,
Manual Adjustment (in place of riveted) and 3.25
to 1 Rear Axle Ratio on Defender and Ranger
Brakes, HD Fade-Resistant with Riveted Linings,
Manual Adjustment (in place of bonded) and 3.50
to 1 Rear Axle Ratio on Sentry
*Cigar Lighter
Fan, Five-Blade
*Lights, Backup
*Mirror, Outside Body Mount, Full-View
(left or right side)
Radio Noise Suppression Equipment
Tires, 7.00 x 14 4-pr. BSW Nylon Tubeless
Upholstery and Trim Set—Two-Tone Embossed
Metallic Gold Beige with Medium Beige All-Vinyl
Deletion of MagicAir Heater

DSO—Special Order Items

Alternator Options—60-Amp. HD Standard or EHD
Types or 100-Amp. EHD with Built-In Silicon
Rectifier
*Belts, Front Seat Only, Driver or Passenger
Conduit, 1¼" I.D. for Radio Cable
Filters, Fuel, Ceramic Type
Gauge, Charge Indicator
Gauge, Oil Pressure
Horn Ring
*Light, Glove Compartment
Lights, Simultaneous Flashing, Parking and Tail-
lights
Lights, Simultaneous Flashing—Red Grille Lights
and Taillights
Locking System, Single Key (one key for all locks in
car)
*Mirror, Inside, Non-Glare
Mirror, Outside-Mounted, Door (left or right side)
Spotlight—Cowl Mount without Mirror (specify red
flashing or clear sealed beam)
Spotlight—Door Mount with Mirror (specify red
flashing or clear sealed beam)
Suppression Spark Plugs with Non-Suppressed
Ignition Wiring
Throttle, Hand, Locking Type

Dealer Installed Items

Clock, Electric, Self-Regulating
Extinguishers, Fire
Washer, Windshield
Plus many other customary accessories

*Also dealer installed

[†]Heater is installed during production unless otherwise specified. If deleted,
an appropriate price reduction is made.

Explanation of Terms

RPO—Regular Production Option. Equipment adver-
tised nationally and available without delay in pro-
duction.

LPO—Limited Production Option. Equipment gener-
ally used only by fleet and commercial accounts.
Slight delays possible.

DSO—Domestic Special Order. Specific procure-
ment, with time necessary to fill order.

1964 FAIRLANE SERIES BRINGS A NEW DIMENSION TO POLICE CARS

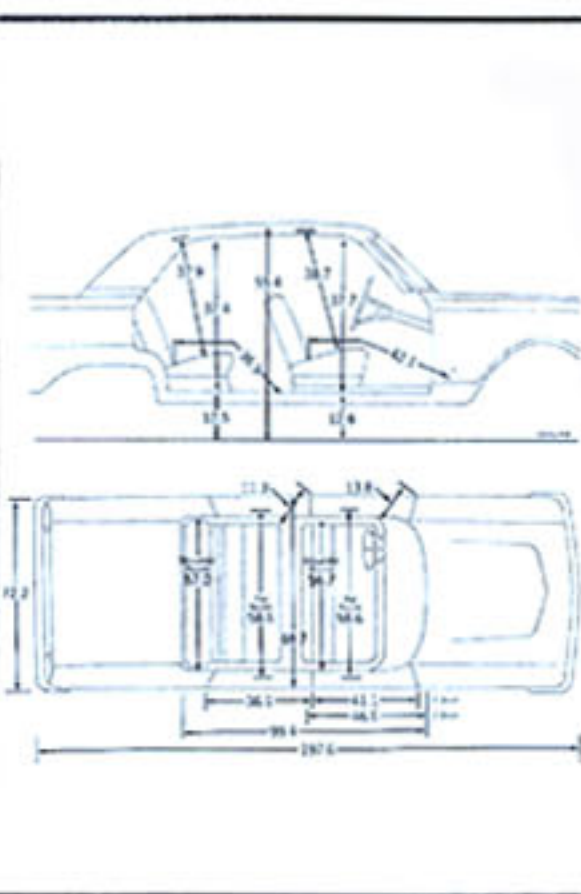
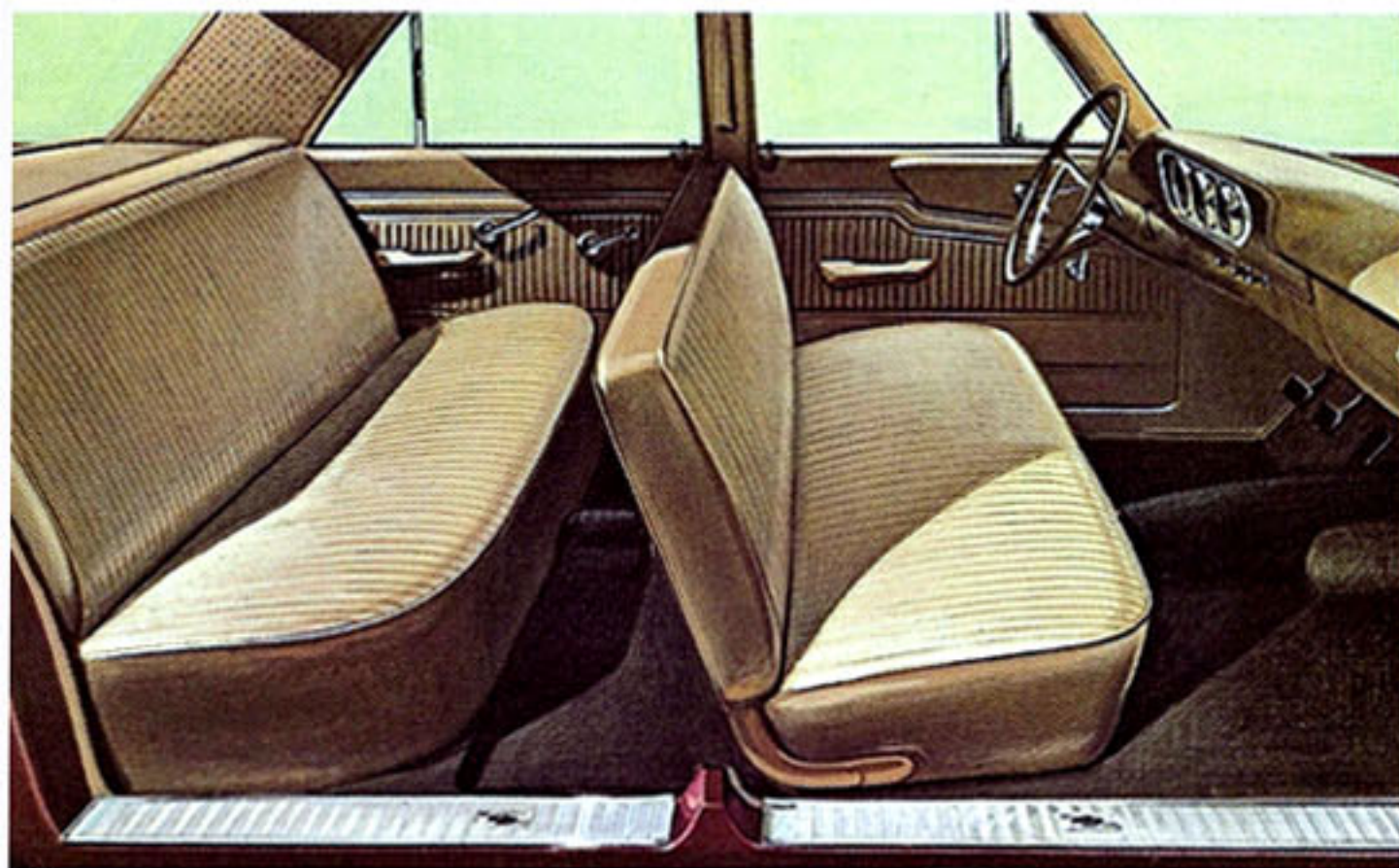

FULL-SIZE INTERIOR ROOM FOR ALERT COMFORT

Fairlane's trim exterior encloses a roomy interior which has full-size dimensions that make riding comfortable, even on long-hour cruising. Police Package seats are heavy-duty, full-width type with firm spring support and thick padding—foam in cushions—for extra comfort and durability. Standard cloth and vinyl, or optional all-vinyl upholstery is attractive, long-wearing and easy to clean. Package floor mats are wear-resistant heavy-duty black rubber, front and rear.

SPECIAL FAIRLANE FEATURES

- ★ More front head room and leg room than in many other police cars on the road today
- ★ Full-size door and window controls are conveniently located and well-proportioned to make operation easy
- ★ Full protection against noise and weather by generous applications of insulation sound deadening materials, and efficient door and deck lid seals

FAIRLANE HEAVY-DUTY POLICE EQUIPMENT

ALTERNATOR-GENERATOR SELECTION

Generating systems must supply the total electrical load requirement for average driving speed plus sufficient output to charge the battery. By adding appropriate constant and intermittent load items from the table below, you can estimate the total load for your vehicle. In totaling intermittent loads, use only a percentage of each load figure that represents its normal time in use (full-time 100%, 1/2 time 50%, etc.). System output characteristics should closely match vehicle operation. Curves at right show alternator and generator cut-in or low-speed characteristics, performance curve slope, and rated current output as related to vehicle speed.

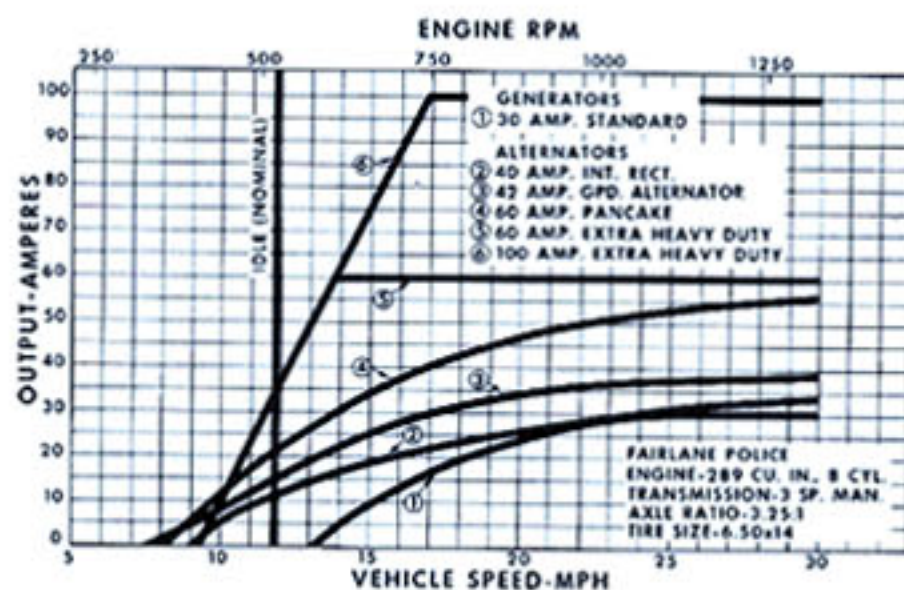

AVERAGE AMPERE-DRAW FOR ELECTRICAL EQUIPMENT

Constant-Load Equipment:	2-Way Radio (stand-by)	Backup Lights	3.5
Ignition & Gauges	Tube-Type	Glove Box Light	0.3
Lighting Draw (incl. lamps turned on by headlight sw. Select one, Low or High):	Full Transistor	Work Light	0.7
"Low Beam"	Intermittent-Load Equipment:	Wipers, 1-Speed	2.3
"High Beam"	Turn Signals	Wipers, 2-Speed (low)	3.0
Heater Blower	Spotlight	Wipers, 2-Speed (high)	2.2
		Entertainment Radio	1.2
		Police Roof Flasher	8.0
		Sires	70.0

HD SUSPENSION increases load capacity, resists "bottoming" and helps to give better driving control; safer, more precise handling and stability at highway pursuit speeds.

HD CLUTCH has 10.4-inch face on V-8's (9 1/2-inch for Six) for longer life under rugged conditions. Ball-type release bearing has pressure lubrication fitting.

HD SEATS, included front and rear in all packages, have heavier gauge springs and thick padding (foam in cushions) for extra support and long patrol duty comfort.

HD FADE-RESISTANT BRAKES have 185-sq. in. riveted linings, groove-cooled drums, manual adjustment. Heavy-duty bonded-type brakes are also available.

FAIRLANE PUTS THE EMPHASIS ON COMFORT AND SAFETY



EASY-ENTRANCE FRONT DOORS give large opening clearance for quick-action entry and exit. Lower hinge spring assists in swinging doors open or closed, and hold them full open when desired for extra convenience in entering or leaving the front seat area.



POSTURE-PERFECT SEATS provide a restful 23° seat angle for a more comfortable ride, even on long patrol duty. Heavy-duty seat, shown, has heavier spring design and thick padding (foam in cushions) for firm seating support and extra durability.



SAFETY-SIGHT VISIBILITY with wide-view windshield and full-sweep, tandem-action wipers. Single-speed electric wipers maintain constant speed under all road-load driving conditions. Full-width back window and narrow body pillars minimize blind spots.



LIFEGUARD STEERING WHEEL features safer three-spoke deep-recessed hub design which supports wheel rim uniformly, gives extra protection against steering post injuries in event of collision. Front seat belt anchors are solidly built into the floor-frame structure.



SYNCHRO-SMOOTH MANUAL TRANSMISSION is fully synchronized in all three forward speeds to permit smooth shifting, even in low gear. Shift lever is column mounted. Package transmission with 101-hp Six or both V-8's. Not available with 116-hp Six.

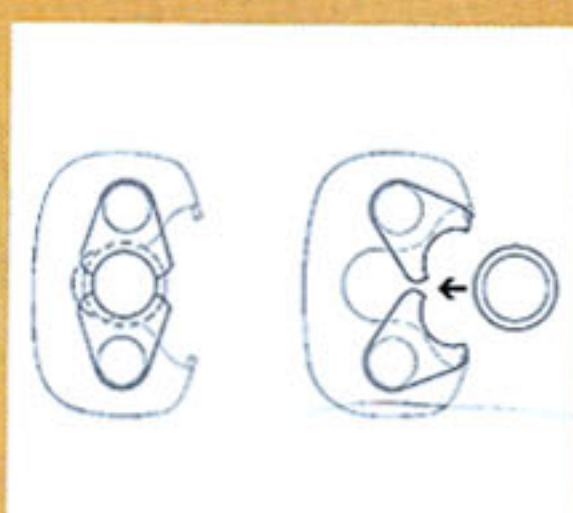

SAFETY-YOKE DOOR LATCHES close easily and securely, give high resistance to pull-apart forces for greater safety of occupants in event of collision. Self-aligning latch action reduces door rattles and helps keep doors tightly closed and in better alignment.

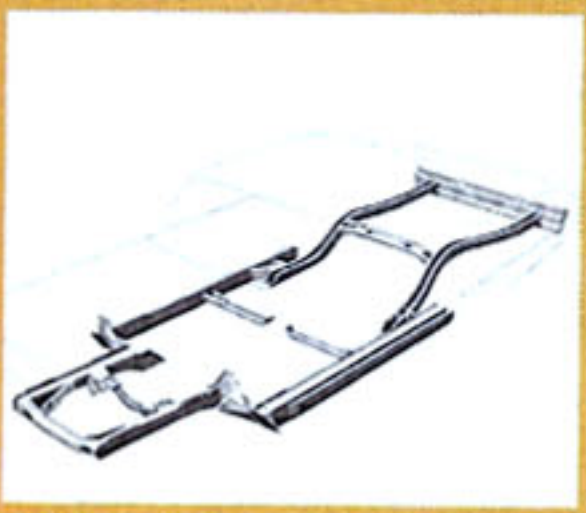

TORQUE BOXES are an important part of Fairlane's solid, quiet ride. Four box structures, located at body corners, "tune out" road noises, vibration and ride harshness by torsion (twisting) action which produces a smoother, more comfortable ride.

PLUS FAIRLANE SERVICE-SAVING FEATURES

- ★ 36,000-Mile (or 3-year whichever comes first) Chassis Lube Interval: Steering linkage, front suspension system, universal joints. Fuel filter*. Air cleaner
- ★ 36,000-Mile (or 2-year) Interval Coolant-Antifreeze. Factory installed
- ★ 6,000-Mile (or 6-month) Oil and Oil Filter Change*
- ★ No 1,000-Mile Break-in Oil Change
- ★ Rust-Resistant Body
- ★ No-Wax Diamond Lustre Enamel Finish
- ★ Double-Wrapped Aluminized Muffler

*Oil and oil filter change each 3,000 miles and 24,000-mile fuel filter replacement recommended for vehicles in prolonged slow-speed and/or idling operations.



HIGH CAPACITY REAR AXLE has offset, hypoid design with rugged, large-tooth drive pinion and ring gear for quiet, long-life service. Drive pinion has a straddle-mounted bearing design with three roller bearings for extra strength and durability.

1964 FORD POLICE CAR SPECIFICATIONS

FORD CUSTOM, FORD CUSTOM 500 AND WAGON

ENGINES: **330-hp Police Interceptor 4V/390 V-8**—390-cu. in. displ., 4.05" bore x 3.78" stroke; 10.1 to 1 comp. ratio; premium fuel; 2-stage, 4-venturi carburetor with automatic choke; 6-qt. oil capacity with filter change; copper-lead main and connecting rod bearings; dual exhausts. Special features include high-lift camshaft, solid lifters; high performance springs with solid retainers and integral damping springs; free-breathing air cleaner, forged alloy exhaust valves with chromed stems; low-restriction header-type exhaust manifolds; plus other hi-speed and long-life features. **300-hp Thunderbird 4V/390 V-8**—390-cu. in. displ., 4.05" bore x 3.78" stroke; 10.1 to 1 comp. ratio; premium fuel; 2-stage, 4-venturi carburetor with automatic choke; free-turn valves with hydraulic lifters for automatic adjustment; precision-molded crankshaft; copper-lead main and connecting rod bearings; 6-qt. oil capacity with filter change; dual exhausts. **250-hp Thunderbird 4V/352 V-8**—352-cu. in. displ., 4.00" bore x 3.50" stroke; 9.3 to 1 comp. ratio; regular fuel; 4-venturi carburetor with automatic choke; free-turn valves with hydraulic lifters for automatic adjustment; precision-molded crankshaft; copper-lead main and connecting rod bearings; 6-qt. oil capacity with filter change; dual exhausts. **195-hp Challenger 289 V-8**—289-cu. in. displ., 4.00" bore x 2.87" stroke; 9.0 to 1 comp. ratio; regular fuel; 2-venturi carburetor with automatic choke; hydraulic lifters for automatic valve adjustment; precision-molded crankshaft; 5-qt. oil capacity with filter change; Y-type single exhaust. **138-hp Police Special Six**—223-cu. in. displ., 3.62" bore x 3.60" stroke; 8.4 to 1 comp. ratio; regular fuel; full economy carburetor with manual choke; solid valve lifters and self-locking adjusting screws; copper-lead main and connecting rod bearings; oil-bath air cleaner; inverted-design fuel pump with positive oil drainback; induction-hardened alloy iron camshaft with heavy-duty timing gears and cast iron case; disposable cartridge-type Full-Flow oil filter; 5-qt. oil capacity with filter change; single exhaust.

CLUTCHES AND TRANSMISSIONS: **Heavy-Duty Clutches** in Police Packages have extra-thick facings, pressure-lube fitting on release bearing, needle-roller bearings in release lever fulcrum points, and extra-capacity pressure-plate springs. All are semi-centrifugal type. Face diameter and frictional area is: 11" (113.1 sq. in.) with 390 and 352 V-8's; 10.4" (103.5 sq. in.) with 289 V-8; 11" (123.7 sq. in.) with Six. Standard sedan clutch face diameter and frictional area: 11" (113.1 sq. in.) with 390 and 352 V-8's; 10.4" (101.9 sq. in.) with 289 V-8; 9½" (85.22 sq. in.) with Six. **3-Speed Manual Transmission** (standard all engines) is fully synchronized in all forward speeds, with hardened and shot-peened alloy-steel helical gears, and forged bronze synchronizers. **4-Speed Manual Transmission** (optional for 390 V-8's) is fully synchronized in all forward speeds, with floor-mounted shift lever. **Overdrive** (optional except with 352 V-8) has 3-speed manual transmission plus automatic 4th gear that cuts in above 28 mph and cuts out below 21 mph (approx.), with downshift for passing by flooring accelerator. Lockout control on instrument panel. **Cruise-O-Matic Transmission** (optional all engines) is 3-speed automatic transmission with dual range drive selection: three-speed range starting in low for all normal driving, or two-speed range starting in intermediate for gradual acceleration on slippery surfaces. Vacuum-controlled transmission throttle valve. **Interceptor Cruise-O-Matic** is specially calibrated for faster upshift at higher rpm's.

REAR AXLE: **Police Package heavy-duty axles on sedans** (standard on wagons) are semi-floating type with deep-offset hypoid gears and straddle-mounted drive pinion. Also included, with fade- or wear-resistant brakes, are higher capacity wheel

bearings and large diameter axle shafts. For axle ratios see power team specifications on pages 4, 5 and 7.

GEAR RATIO (to 1)	3-Speed Manual			4-Speed Manual	Overdrive		Cruise -O- Matic All
	Six	289 V-8	390 & 352 V-8's	390 V-8	Six & 289 V-8	390 V-8	
1st (low)	3.26	2.79	2.42	2.36	2.80	2.49	2.40
2nd	1.84	1.70	1.61	1.78	1.69	1.59	1.47
3rd	—	—	—	1.41	—	—	—
Direct	1.00	1.00	1.00	1.00	1.00	1.00	1.00
Overdrive Reverse	—	—	—	—	.70	.72	—
Reverse	3.35	2.87	2.33	2.42	3.80	3.15	2.00

ELECTRICAL: 12-volt electrical system with 30-amp. generator. Police Package has 66-plate, 70 amp-hr battery (78-plate, 65 amp-hr in Sentinel). Standard sedan has 66-plate, 55 amp-hr battery. Weatherproof ignition system with Static-Ban constant resistance wiring and air-cooled distributor points; 18-mm. Turbo-Action spark plugs; inertia-engagement starter.

SUSPENSION: Front—Angle-Poised ball-joint type with 20° sweepback; ball joints packed with special 36,000-mile or 3-year grease retained by full-life seals, internally mounted shock absorbers. Tapered roller wheel bearings are checked every 24,000 miles and repacked as required. **Police Package** has reinforced mono-pivot lower front suspension arms with lube fittings on upper inner arm bushings, plus heavy-duty coil springs, shock absorbers, and front stabilizer bar. Rear—Asymmetrical, variable-rate design with rear axle located well forward from center of springs for anti-dive and anti-squat on braking and acceleration. Extra-long, gentle-rate, leaf-type springs with wide spring base for stable, levelized ride. Tension-type shackles. Diagonally mounted shock absorbers. **Police Package** has heavy-duty springs and shock absorbers.

STEERING: Precision-control, low-friction recirculating ball type steering gear with anti-friction bearings throughout plus high ratio for easier steering. Flexible coupling in steering shaft insulates steering wheel. Symmetrical linkage with nylon bearings in tie rod and pitman arm pivots packed with special 36,000-mile or 3-year grease retained by full-life seals. Over-all steering ratio 30 to 1; with power steering, 23 to 1. Turning diameter 41 feet.

BRAKES: Hydraulic, double-sealed, self-energizing design. Dash-mounted master cylinder. **Police Package heavy-duty brakes** have 234-sq. in. riveted linings (bonded on Deputy) and specially grooved 11" dia. composite drums for maximum cooling and fade resistance. Manual adjustment. Standard sedan brakes have 212-sq. in. (234-sq. in. on Wagons) riveted linings, air-grooved 11" composite drums and self-adjustment. Foot-operated parking brake with hand release under instrument panel. Swift Sure power brakes with special low pedal are optional.

TIRES: Black, tubeless with Tyrex rayon cord, Soft-Tread design. Sedans: Ford Custom—7.00 x 14 4-pr. std. (7.50 x 14 4-pr. opt.) with 2- or 4-door Six or 2-door 289 V-8; 7.50 x 14 4-pr. std. with 4-door 289 V-8, and 2- or 4-door 352 or 390 V-8's. Ford Custom 500—7.50 x 14 4-pr. std. with all engines. Wagons: 8.00 x 14 4-pr. std. with all engines. Safety-type rims; sedans 5½", wagons 6". Optional 15 x 5½" wheels with 6.70 x 15 or 7.10 x 15 tubeless or tube-type tires recommended for prolonged high speed conditions.

DIMENSIONS: Wheelbase—119". Tread—front 61.0", rear 60.0". For other dimensions, see pages 9 and 10.

PRICES: All power assists, optional equipment and accessories as well as some items illustrated or referred to as options, optional or available in this catalog are at extra cost. For the price of the model with the equipment you desire, see your Ford Dealer.

Comparative information in this catalog was obtained from authoritative sources, but is not guaranteed. The specifications contained herein were in effect at the time this catalog was approved for printing. Ford Division of Ford Motor Company reserves the right to discontinue models at any time, or change prices, specifications or design without notice and without incurring obligation.

FAIRLANE

ENGINES: **195-hp Challenger 289 V-8** (opt.)—289-cu. in. displ., 4.00" bore x 2.87" stroke; 9.0 to 1 comp. ratio; regular fuel; 2-venturi carburetor; automatic choke; self-adjusting valves with hydraulic lifters; 5-qt. oil capacity with filter change; Y-type single exhaust. **164-hp Challenger V-8** (opt.)—260-cu. in. displ., 3.80" bore x 2.87" stroke; 8.8 to 1 comp. ratio. Other specifications same as 289 V-8 above. **101-hp Fairlane Six** (std., available only with 3-spd. trans.)—170-cu. in. displ., 3.50" bore x 2.94" stroke; 8.7 to 1 comp. ratio; 1-venturi carburetor; manual choke; self-adjusting valves with hydraulic lifters; 4.5-qt. oil capacity with filter change; single exhaust. **116-hp Fairlane Six** (opt., available only with Fordomatic)—200-cu. in. displ., 3.68" bore x 3.13" stroke. Other specifications same as 170 Six above.

CLUTCHES AND TRANSMISSIONS: **Heavy-duty clutches** in Police Packages have same design as Ford Custom and Ford Custom 500. Six is 9½" dia. (85.2 sq. in.), V-8's are 10.4" (103.5 sq. in.). Standard sedan clutch for Six is non-centrifugal design with 8½" dia. face (68 sq. in.); 260 V-8 has 10" dia. face (85.5 sq. in.); 289 V-8 has 10.4" dia. face (103.7 sq. in.). V-8's are both semi-centrifugal design. **3-Speed Manual Transmission** (standard with 101-hp Six and both V-8's)—Fully synchronized in all forward speeds. **4-Speed Manual Transmission** (opt. with 289 V-8)—Floor shift, same features as with Ford. **Overdrive** (optional, 260 V-8 only)—3-speed transmission, plus automatic 4th gear, similar to Ford Overdrive. **Cruise-O-Matic Transmission** (opt. with 289 V-8)—Automatic 3-speed, same features as with Ford. **Fordomatic Transmission** (opt. with 260 V-8, also available with 116-hp Six only)—2-speed automatic transmission, single-stage torque converter with planetary gear train. Vacuum-controlled throttle valve for smoother shifting.

GEAR RATIO (to 1)	3-Speed Manual		4-Speed Manual	Over-Drive	Cruise -O- Matic	Fordomatic
	Six	289 & 260 V-8's	289 V-8	260 V-8	289 V-8	Six & 260 V-8
1st (low)	2.79	2.79	2.74	2.80	2.46	1.82
2nd	1.70	1.70	2.04	1.69	1.46	—
3rd	—	—	1.51	—	—	—
Direct	1.00	1.00	1.00	1.00	1.00	1.00
Overdrive Reverse	—	—	—	.70	—	—
Reverse	2.87	2.87	2.81	3.80	2.20	1.73

REAR AXLE: Semi-floating type with deep-offset hypoid gears. Straddle-mounted drive pinion. For axle ratios see power team specifications on pages 12 and 13.

ELECTRICAL: 12-volt system same as Ford models except HD 54-plate, 55 amp-hr Police Package battery. Standard sedan battery is 54-plate, 40 amp-hr (Sixes), 54-plate, 55 amp-hr (V-8's).

SUSPENSION: Front—Angle-Poised ball-joint design with coil springs mounted on upper arms and shock absorbers internally mounted. Other features similar to Ford models. Rear—Leaf-type springs with variable-rate characteristics. Asymmetrical design. Compression-type shackles. Spring tip liners between all but top leaves. Diagonally mounted shock absorbers. **Police Package suspension** includes heavy-duty springs and shock absorbers, front and rear.

STEERING: Same type as Ford models. Over-all steering ratio 27.8 to 1. Optional ratio with power steering 25 to 1. Turning diameter 40.2 ft.

BRAKES: **Heavy-duty Police Package brakes** same as Ford models except 10-inch drums. (Sentry has bonded linings—3.25 to 1 axle ratio.) Package brake area 185 sq. in. Standard sedan brake area 154 sq. in. Offset "L" handle parking brake at left of steering column. Power brakes optional; Fade-Resistant riveted brakes available for Sentry (with 3.50 to 1 axle ratio).

TIRES: 6.50 x 14 4-pr. blackwall tubeless with Tyrex rayon cord, Soft-Tread design. 5" safety-type rims. Optional: 7.00 x 14 4- or 6-pr. rayon or 4-pr. nylon BSW tubeless.

DIMENSIONS: Wheelbase—115.5". Tread—front 57.0", rear 56.0". For all other dimensions see page 14.

PRODUCTS OF  MOTOR COMPANY