Ford Falcon '62



BEST SHAPE ECONOMY'S EVER BEEN IN



Falcon for '62: More from the car America loves most! More models, more savings, more everything!

Count all the wonderful ways Falcon is new. **NEW STYLING:** crisp, smart new looks all around. **NEW MODELS:** 14 in all, headlined by the distinctive Falcon Squire (below left) and lively new Sports Futura (below right), the newest ideas in compact luxury, plus the new Falcon Station Bus and two new Falcon Club Wagons (see pages 10, 11). **NEW LUXURY:** 27 interior trim choices, plus many standard features other compacts charge extra for. **NEW ALL-ROUND ECONOMY:** new improved version of the famous Falcon Six that in '61 set an all-time economy record for 6's and 8's in the Mobilgas Economy Run. Only Falcons, among compacts, go 6,000† miles between oil changes . . . two years or 30,000 miles between changes of engine coolant-antifreeze. **FAMOUS LOW PRICE:** Falcon's always led with the lowest. The '62 Falcon line includes America's lowest-priced* 6-passenger sedan and lowest-priced* 6-passenger, six-cylinder wagon (see pages 5, 13)! So—add up all the ways Falcon is new. Then see all the news in Falcon at your Ford Dealer's.



FALCON SQUIRE in Viking Blue



FALCON SPORTS FUTURA in Sandshell Beige with white vinyl-covered roof

Cover: FALCON SPORTS FUTURA in Castilian Gold with black vinyl-covered roof



FALCON SEDAN STANDARD EQUIPMENT

Falcon Six Engine (144-cu. in.) \ 3-Speed Manual Transmission \ Full-Flow Oil Filter \ Fully Aluminized Muffler \ Zinclud Rocker Panels and Main Underbody Structural Members \ Bright-Metal Windshield, Rear Window and Drip Rail Moldings \ Parallel Action Windshield Wipers \ Two Horns \ Foam-Cushioned Front Seat \ White Vinyl Headlining \ Two Front Safety-Padded Arm Rests \ Two Sun Visors (with retention clips) \ Coat Hooks \ Deep-Dish 3-Spoke Steering Wheel \ Body, Roof, Floor, Hood and Dash Insulation \ Front Seat Belt Anchors \ Center-Fill Fueling \ (For Options and Accessories, see page 16.)

More miles on less gas than ever before recorded by a 6 or 8 in the 25-year history of the Mobilgas Economy Run! That's what Falcon's standard 144 Six with manual transmission did in '61 against a full field of expert drivers. Now this famous engine has been improved—the peppery 170 Special Six option has been, too! What more could be said for economy!



FALCON TUDOR SEDAN in Silver Moss with standard trim (offered also in Fordor model)

Standard Sedan Interior. This Falcon front seat of smart nylon pattern cloth edged in vinyl tells you who sets the standards in compact car style, comfort and convenience. Wide and foam-cushioned, it is the *deepest* seat in any compact. Falcon's steering wheel is 3-spoke, deep-dish safety design and comfortably 17 inches big. In every Falcon you get *two* sun visors (with handy retention clips), *two* front arm rests . . . even *two* coat hooks. And, just see how wide that Falcon front door opens to welcome you and five other folks inside!



TUDOR SEDAN. Here's the car whose standard equipment list has set the standards for all other compacts. And, if you compare Falcon features from the list opposite against the field, you'll see the other compacts aren't "up to standard" yet! \ Actually, Falcon has many more items that could be added to the list. For example—a big one—6-passenger comfort. And that means, naturally, room for heads and shoulders, hips and legs. Another item, economy. With Falcon that begins with the price tag—lowest* for any 6-passenger sedan in America! (This year Falcon's low price means more than ever because it *includes* fresh air heater,* too.) \ And this is just a good beginning. For more, talk to any Falcon owner.

*Based on a comparison of manufacturers' suggested retail delivered prices, including heater. Heater is installed during production unless otherwise specified. If deleted, an appropriate price reduction is made.

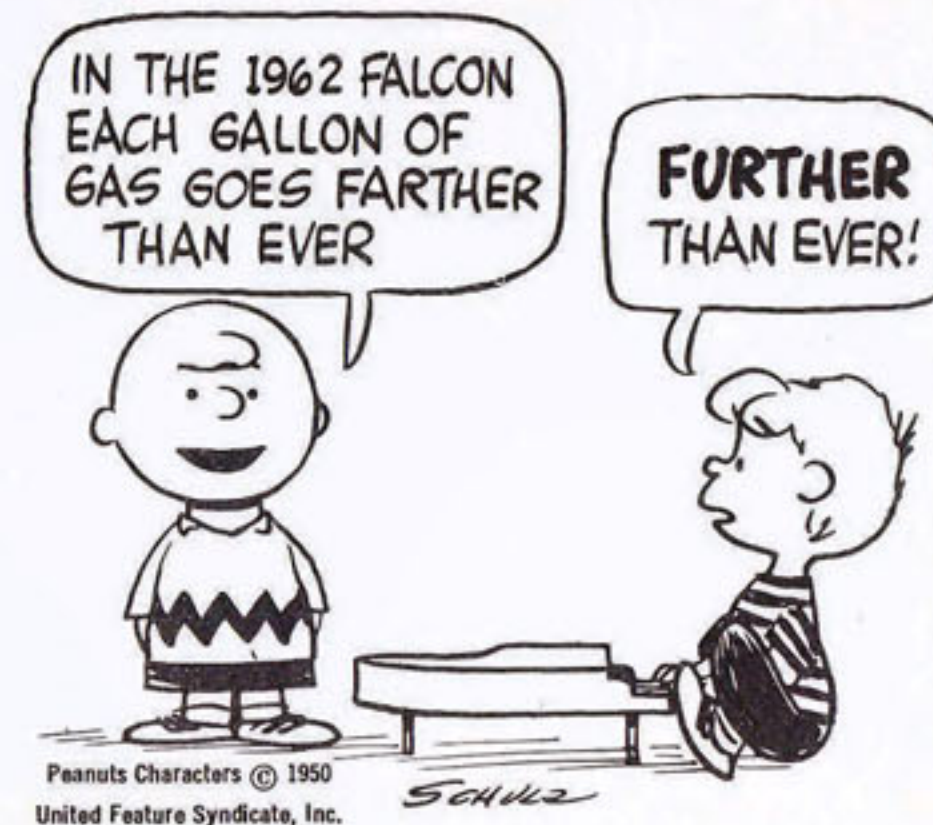

Peanuts Characters © 1950
United Feature Syndicate, Inc.



FALCON SEDAN DELUXE TRIM

Includes most Standard Equipment listed on page 4 plus the following Deluxe trim package . . .

Bright-Metal Window Frames, Deluxe Body Trim and Side Moldings ↘ Fender Top Ornaments ↘ Choice of Five Pleated Nylon and Vinyl Interior Trims (or three in all-vinyl*)
 ↘ Rich, Color-Keyed, Wall-to-Wall Carpeting
 ↘ Arm Rests and Ash Trays, Front and Rear
 ↘ Cigarette Lighter ↘ Deluxe White Steering Wheel with Chrome Horn Ring ↘ Dome Light Operated by Front Door Courtesy Switches (For Options and Accessories, see page 16.)

*Extra cost

Big Falcon Trunk—big enough to carry all the luggage of the six happy folks riding up front. Measures 23.7 cubic feet in all. So easy to load and so convenient (flat, wide space and all in one place)! Another kind of convenience is Falcon's Center-Fill fueling (fuel port shown in lower trunk sill). Makes filling easy from either side.



Deluxe Sedan Interior. Rich turquoise in deep-pleated nylon inserts and vinyl seat bolsters is one of five stunning trim color choices. The headlining is of snow-white vinyl; below, color-keyed nylon-rayon loop carpet stretches wall to wall. Many Falcon owners who "go deluxe" also specify optional color-keyed padded instrument panel and white padded visors shown here. They enhance interior styling as they add to the safety of front seat passengers. Radio and Fordomatic transmission are among the most highly favored Falcon options.



FALCON FORDOR SEDAN in Ming Green with Deluxe trim (offered also in Tudor model)

FORDOR SEDAN. Nearly 65% of all Falcon buyers order their cars with Deluxe trim, like the one above. Still, these folks came to Falcon first for savings. And they were as pleased as they were amazed to find a Falcon with full Deluxe trim (listed opposite) actually costs less than many other compacts with standard trim! ↘ Even in their Deluxe models some other compacts do not offer at any price features which are standard on every Falcon. Examples: 3-spoke, deep-dish, safety steering wheel; sturdy one-piece, deep-section (8") bumpers providing greater protection front and rear; Zinclad underbody members (rust protection); 6,000 miles between oil changes* (less service expense). ↘ Over 1,000,000 Falcons on the road prove people find more of what they want from a compact in a Falcon!

*After first 1,000-mile change

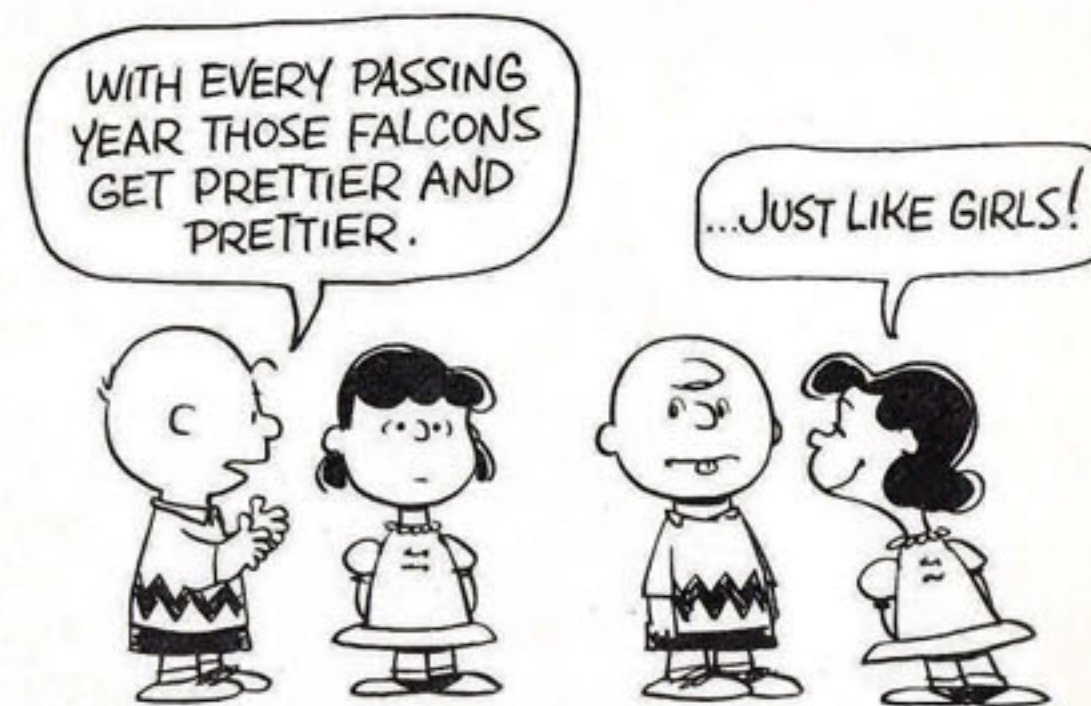



SPORTS FUTURA STANDARD EQUIPMENT

Includes most Standard Equipment and Deluxe trim items listed on pages 4 and 6, plus . . .

Pleated, Foam-Cushioned (100%) Front Bucket Seats \ Between-the-Seats Console \ Foam-Padded Rear Seat Cushion \ Choice of Five All-Vinyl Interior Trims \ Unique White Whipcord Vinyl Headlining \ Futura Arm Rests and Ash Trays, Front and Rear \ Distinctive Bright-Metal Trim Includes: Emblem on Glove Compartment Door, Louver Front Fender Side Ornament, Side Spear, Rear Quarter "Futura" Script, and "Futura" in Block Letters on Rear Panel, Gold Falcon Ornament on Roof Quarter \ Sports Futura Full Wheel Covers with Tricolor Centers

Luxury Roof Option. Sports Futura goes all the way in elegance! You can have your Futura with its new Thunderbird roofline finished in gleaming Diamond Lustre Enamel. Or, as an option, the roof comes padded and trimmed in your choice of black or white grained vinyl—the luxury look of leather with none of leather's special care. Either way, finished in steel or vinyl, the golden Falcon roof emblem marks your car as the one . . . the only "compact cousin of the Thunderbird."



Lively & Luxurious!



FALCON SPORTS FUTURA in Rangoon Red

Sports Futura Interior. Bucket front seats are elegantly pleated, contoured and foam-cushioned for superb comfort. Each adjusts individually . . . folds far forward to accommodate those in the rear. (Three-passenger rear seat mirrors the "bucket look.") Nestled between the front seats is the Futura console, a luxury touch straight from Thunderbird. Fingertip-close to driver or passenger, the console lid opens at a touch to reveal an ample personal storage compartment for your camera, gloves, sunglasses, maps or what-have-you.



SPORTS FUTURA. Here is Ford's new "Lively One" in the compact size! A delight to the eye with a new Thunderbird-inspired roofline (plus interiors to match) and a pure delight to drive.

\ Here is the liveliest "going" among compacts—a beautiful blend of power and top gas savings in the Falcon Six engine, or, if you prefer, the extra zip and dash of the 170 Special Six option. Three transmission choices, starring a new 4-Speed Manual* with floor-mounted stick shift. The handling would win praise from many a sports car fan. The ride is best described as "big car" all the way! \ Best of all, this fun-car performance is yours in *every* other Falcon sedan as well! One more big reason why Falcon, with more than a million on the road, is the car America loves most!

*Extra cost



Deluxe Club Wagon Interior. Walk right in with the whole gang! Big double doors swing back to give you a side opening fully 4 feet wide. Auxiliary step slides out to meet you as doors are opened. Individual seats up front for driver and passenger, two 3-passenger seats (optional) behind. All seats are pleated and chair-height—that's solid comfort for eight in the style of Falcon's new Deluxe Club Wagon. Two-tone pleated vinyl trim scheme is carried through seats, doors and side panels.



Falcon's Station Bus, Club Wagon and Deluxe Club Wagon (illustrated) are the biggest Falcons by far. They can carry up to eight passengers or 204 cubic feet of cargo. So wonderfully versatile, too—they're as much at home on a vacation camping trip, a shopping trip or the twice-daily trip to school. Thrifty and economical as any member of the Falcon family, they carry three of the *lowest* price tags (and fresh air heater* is *included* in the base price of each one)!

STANDARD EQUIPMENT†

Falcon Station Bus

Falcon Six Engine (144-cu. in.) \ 3-Speed Manual Transmission \ 2-Speed Electric Windshield Wipers \ Deep-Dish 3-Spoke Steering Wheel \ Foam-Cushioned Adjustable Driver's Seat \ Front Arm Rests \ Seat Belt Anchors, Front Seats \ Dual Horns and Dome Lights \ Left-Hand Sun Visor \ Auxiliary Side Step \ Zinclad Main Underbody Structural Members \ Full-Flow Oil Filter (4,000-mile oil change)**

Falcon Club Wagon

All the above equipment *plus* . . . Full-Length Floor Mat and Headlining \ Foam-Cushioned Passenger's Seat \ Painted Outside Mirror \ Windshield Washers \ Cigarette Lighter \ Black Steering Wheel with Chrome Horn Ring \ Dual Sun Visors \ Coat Hooks \ Right-Hand Air Inlet \ Bright Hub Caps

Falcon Deluxe Club Wagon

All Station Bus and Club Wagon equipment above *plus* . . . Falcon 170 Special Six Engine (replaces 144-cu. in. Six) \ White Deluxe Steering Wheel with Chrome Horn Ring \ Padded Instrument Panel \ Pleated, All-Vinyl Upholstery and Side Trim Panels \ (Required options provided at factory include bright-finish bumpers, dual cushioned sun visors and bright-finish, left-hand outside rearview mirror.)

*Delete option. See footnote page 5

†See your Ford Dealer for complete information on equipment, options and accessories

**After first 1,000-mile change

THE NEW FALCON CLUB WAGON IS JUST ONE OF 14 NEW FALCONS FOR '62



THAT'S A SUPER AUTOMOTIVE BAKER'S DOZEN!



FALCON DELUXE CLUB WAGON in Viking Blue



DELUXE CLUB WAGON. Here's the one that most deserves to be called the "family Falcon." It seats eight with ease or takes 204 cubic feet of cargo. Huge double doors at curbside and rear for easy loading and unloading. Trim 90-inch wheelbase gives you the smallest turning circle, tightest maneuverability of all Falcons! An economical way with gas and oil that can only be compared to other Falcons. Visibility is so generous everyone has a window of his own! If yours is a big family that likes to go places together, this family Falcon (or one of the two like it) was made for you!



FALCON WAGON STANDARD EQUIPMENT

Includes Standard Equipment listed on page 4 plus these special wagon features . . .

All-Vinyl Seat Trim with Light Beige Bolsters, "Steerhead" Pattern in Medium Beige Inserts
 \ Foam-Cushioned Seats, Front and Rear
 \ Roll-Down Tailgate Window \ Vinyl-Coated Rubber Floor and Cargo Mat (black)

FALCON WAGON DELUXE TRIM

Includes most equipment on page 4 and above plus the following Deluxe trim package . . .

Bright-Metal Side and Rear Window Frames, Deluxe Body Trim and Side Moldings
 \ Fender Top Ornaments \ Choice of Five Interior Trims: Four Pleated All-Vinyl, One Woven Plastic and Vinyl \ Arm Rests and Ash Trays, Front and Rear \ Cigarette Lighter
 \ Deluxe White Steering Wheel with Chrome Horn Ring \ Dome Light Operated by Front Door Courtesy Switches \ Color-Keyed Floor and Cargo Mats \ (For Options and Accessories, see page 16.)

Loadspace comes big and easy in a Falcon wagon! Second seat flips over quick as "1-2-3" to provide 76.2 cu. ft. of loadspace. Behind the front seat, it measures almost 9 ft. to end of open tailgate (over 7 ft. with tailgate closed), up to 4¾ ft. side to side. It's level, *all-in-one-place* loadspace, too!



FALCON FORDOR WAGON in Sandshell Beige with Deluxe trim (offered also in Deluxe Tudor and standard Tudor and Fordor models)

Deluxe Wagon Interior. Falcon wagons outsell the rest because they clearly outclass any rival. Look at the luxury. This handsome black and white interior is one of five trim selections. Whichever you choose you can be sure of smart styling. You can count on big 6-passenger roominess and comfort too. And, unlike some compacts, foam-cushioned seats front and rear are *standard* as are front and rear arm rests and ash trays. Count also on typical Falcon wagon finishing touches like the color-keyed, vinyl-coated rubber mat that protects the entire cargo floor.



FORDOR WAGON. Falcon is the U.S.A.'s best-selling compact wagon for a whole wagonful of reasons. It's America's lowest-priced,* six-cylinder, 6-passenger wagon. And, as if that weren't enough to insure its popularity, Falcon offers all the best features of the best of the big wagons (Fords, too, naturally!) \ Outside, there's smart wagon styling, the kind that has made Ford America's station wagon specialist. Inside, big 6-passenger spaciousness, the kind that has made Falcon famous. \ Convenience is everywhere: quick-converting second seat . . . roll-down tailgate window . . . counterbalanced tailgate . . . easy-to-reach spare . . . comfortable loading height . . . big 76.2-cu. ft. cargo space plus the *biggest* standard brakes in its class!

*Based on a comparison of manufacturers' suggested retail delivered prices, including heater





FALCON SQUIRE STANDARD EQUIPMENT

Includes most Standard Equipment and Deluxe trim items referred to and listed on page 12, plus . . .

Distinguished Compact Wagon Styling: Limed Oak Glass Fiber Rails Enclosing Walnut-Grained Steel Panels on Sides and Rear
 \ Power Tailgate Window, Operated from Instrument Panel or Tailgate
 \ Choice of Five Interior Trims: Four Pleated All-Vinyl, One Woven Plastic and Vinyl
 \ Color-Keyed Wall-to-Wall Carpeting (passenger area)
 \ (For Options and Accessories, see page 16.)

Counterbalanced Tailgate. Thanks to thoughtful Ford engineering, Falcon's tailgate flips open and shut so easily even a child can do it. Concealed assist springs do all the hard work. Power tailgate window is another thoughtful convenience. So easy to regulate for just the desired amount of straight-through ventilation. For safety, window must be completely lowered *before* tailgate can be opened.

Falcon Squire Interior. Depend on Falcon to be first with compact wagon luxury like this. Pleated all-vinyl seat trim in two-tone metallic blue illustrates one of five offerings. All of them, in addition to their smart good looks, are ruggedly durable and simplicity itself to keep clean. As a most elegant option, you can have a special interior in your Squire with all the flair of the Sports Futura (page 8). Foam-cushioned front bucket seats with personal console in between, matching "Futura-pleated" rear seat, and color-keyed carpeting . . . all available in four trim color choices.



FALCON SQUIRE in Corinthian White

FALCON SQUIRE. The "Thunderbird of wagons," Ford's famous, full-sized Country Squire has given much of its distinction and luxury as well as part of its name to this Falcon wagon. \ The Squire has the look of classic wagon styling. For this Falcon's rich woodlike trim, like its Diamond Lustre Enamel, *never* needs waxing. Just wash and remove any corrosive substances with a good grade of polish. \ As you'd imagine, many features listed "extra" on most other compacts are *standard* on Falcon Squire. Bright-metal window frames, wall-to-wall carpet, power tailgate window . . . to name but three. The price is *low* as only a Falcon can be—right down among the *lowest!*



Falcon Options and Accessories

LIFEGUARD DESIGN. '62 Falcons give you these Lifeguard Design features as standard equipment: safety-padded arm rests, deep-dish 3-spoke steering wheel, and double-grip door locks. Options include: *color-keyed foam-padded instrument panel* (std. on Deluxe Club Wagon) and *white padded sun visors* (req. option on Deluxe Club Wagon), *safety seat belts* and *Lifeguard Jr. rear door safety locks* to prevent tiny hands from inadvertently opening rear doors.

ELECTRIC WIPERS (2-speed). Separate options that Falcon owners often purchase together are 2-speed electric wipers and **WINDSHIELD WASHER.** Floor-mounted pedal regulates flow of twin water jets, automatically turns on wipers to wash away road spatter. (2-speed wipers std. on Station Bus, Club Wagons; washer std. on Club Wagons—wipers, washer not interconnected.)

POLAIRE CONDITIONER. Big capacity (enough to cool a 4-room house) plus fast cool-down for cool, cool comfort on summer's hottest days. Comfortable price, too. Factory-installed. (Similar unit also available for local installation by your Ford Dealer.)

FALCON FORDOMATIC. Falcon owners praise Falcon's proved automatic transmission for its happy blend of brisk pickup, over-all smoothness and gas economy. (Available with both engines on all Falcons except Station Bus and Club Wagons.)

4-SPEED MANUAL TRANS. An option packed with exhilarating thrills for the performance fan. Floor-mounted stick with shift pattern clearly marked on shift knob. (Available with both engines on all Falcons except Station Bus and Club Wagons.)

RADIOS. (Push-button model on sedans and wagons; manual model on Station Bus and Club Wagons.) Outstanding tone quality and power—reasonably priced. Transistor-powered for compactness, dependability, longer life. Adds greatly to your driving pleasure now, adds more to your car's value at trade-in time.

WAGON TOP LUGGAGE RACK. Falcon wagon owners love this option for its handsome, stylish appearance, and because it adds so much to load capacity. Attaches permanently to the roof. Chrome-plated and stainless steel construction to withstand weather, stay bright and attractive with little care. Heavy gauge, weatherproof canvas luggage rack cover available as a separate option.

ADDITIONAL OPTIONS. 170 Special Six Engine (standard on Deluxe Club Wagon) \ Two Tone Paint Combinations \ 54-Plate, 55 Amp-Hr Battery \ Rayon Cord Tires: Sedans—6.00 x 13 white sidewall, 6.50 x 13 black or white sidewall; Wagons—6.50 x 13 white sidewall, or 6-ply black or white sidewall \ Bus and Club Wagons—7.00 x 13 tires (required with optional 2nd, or 2nd and 3rd seats) \ All-Vinyl Interior Trim (Deluxe Sedans) \ Wheel Trim Rings \ License Plate Frames \ Backup Lights \ Power Tailgate Window (std. on Squire) \ Deluxe, Solid Wheel Covers \ Spotlight \ Body-Mounted Rearview Mirrors \ Electric Clock \ I-Rest Tinted Glass \ Deletion of Fresh Air Heater; and many others.

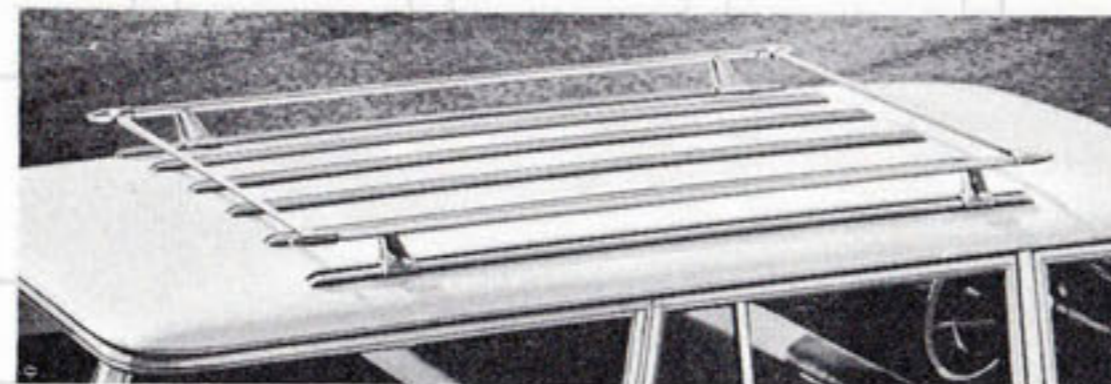
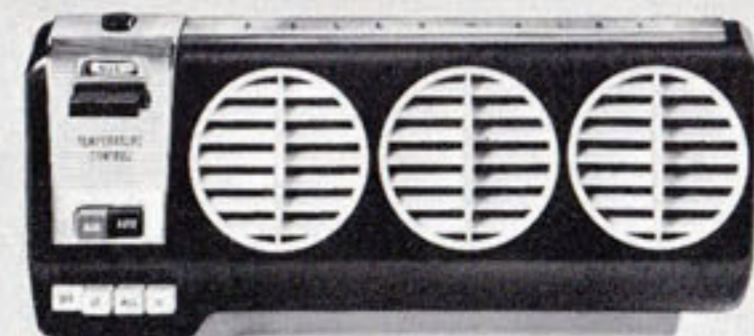

Upholsteries and Colors

Coded color guide below illustrates the 16 Falcon exteriors in Diamond Lustre Enamel—the finish that needs only a wash and a polish to glisten like new. It *never* needs waxing! By simple cross reference you can quickly tell the colors and interior trim choices available with your favorite model. *For example:* the Sports Futura with blue all-vinyl interior comes in White (M), or a choice of three Blues (F), (E) and (H).

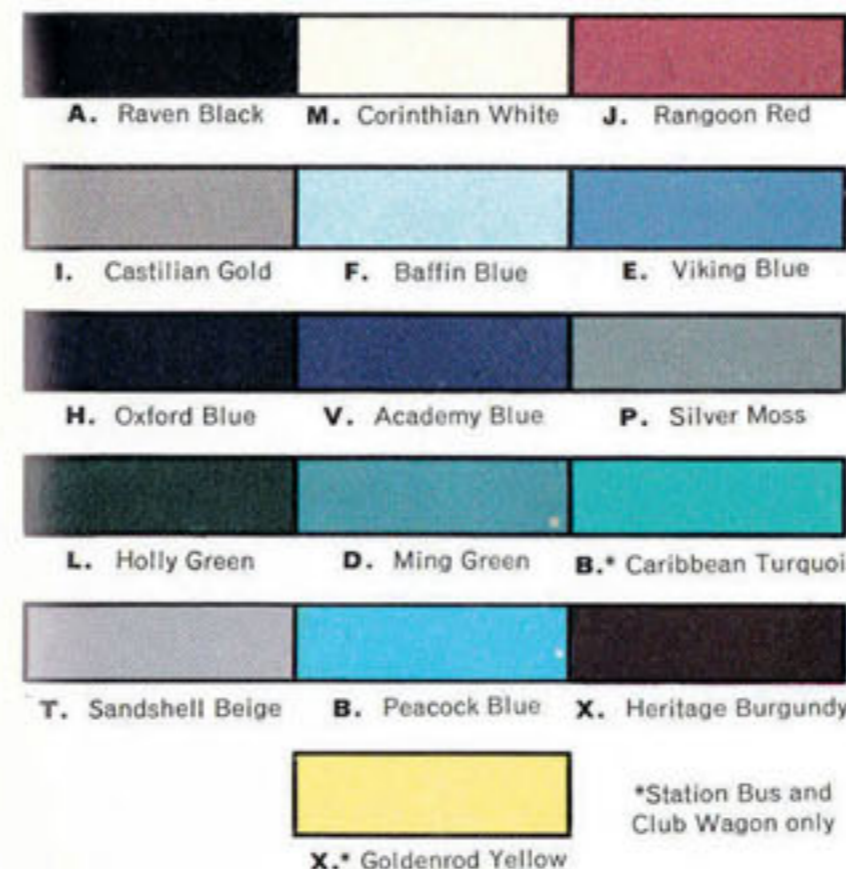

EXTERIOR COLOR CHOICES	STD. SEDAN	DELUXE SEDAN	SPORTS FUTURA	STD. WAGON	DELUXE WAGON & SQUIRE	BUS & CLUB WAGON
Deluxe Club Wagon—F • E • V All Others—M • F • E • H		Blue Vinyl/Pleated Cloth	Blue Pleated All-Vinyl†		Blue Pleated All-Vinyl	Blue Pleated All-Vinyl
Std. Sedan, Deluxe Wagon & Squire—A • M • J • I • F • E • H • P • D • T • B • X Deluxe Sedan—A • M • J • I Sports Futura—A • M • J • I • P • X Station Bus—A • M • J • F • V • L • B • T • X*	Gray Vinyl/Cloth	Gray Vinyl/Pleated Cloth	Black Pleated All-Vinyl		White Vinyl/Pleated Black Vinyl	Beige All-Vinyl
Deluxe Sedan—M • T • X Sports Futura—M • P • T • X Std. Wagon—A • M • J • F • E • H • P • D • T • B • X Deluxe Wagon & Squire—A • M • J • F • E • H • P • D • T • B • X Club Wagon—A • M • J • F • V • L • B • T • X*		Pearl Vinyl/Beige Pleated Cloth	Pearl Vinyl/Beige Pleated Vinyl†	Beige All-Vinyl (Steerhead)	Pearl Vinyl/Beige Woven Plastic	Beige Vinyl/Woven Plastic
Deluxe Sedan (1)—M • P Deluxe Sedan (2) & Futura—M • D • B Deluxe Wagon & Squire—M • T • X		Green Vinyl/Pleated Cloth (1)	Turquoise Vinyl/Pleated Cloth (2)		Pearl Vinyl/Pleated Vinyl	
All Models—A • M • J • I		White Vinyl/Red Pleated Vinyl†	Red Pleated All-Vinyl		White Vinyl/Red Pleated Vinyl	

†Extra-cost option on Deluxe Sedans

TWO TONE COMBINATIONS. There are 17 Diamond Lustre two-tone combinations available for '62 Falcons. (The Squire comes only in solid colors. Deluxe Club Wagon is available in any one of the three single blues or two tones of blue and white.)

Using the color guide below, you can easily select a Two Tone for your favorite Falcon. In each, the first letter represents top color, the second body color. *For instance:* "M/A" is White over Black. (Bus two-tone scheme is dark-white-dark.) In all cases lower body color determines interior trim choices.



M/A	M/J	M/I	A/I	M/F	M/E	F/E	M/H	M/V
M/P	M/L	M/D	M/B*	M/T	M/B	M/X	M/X*	

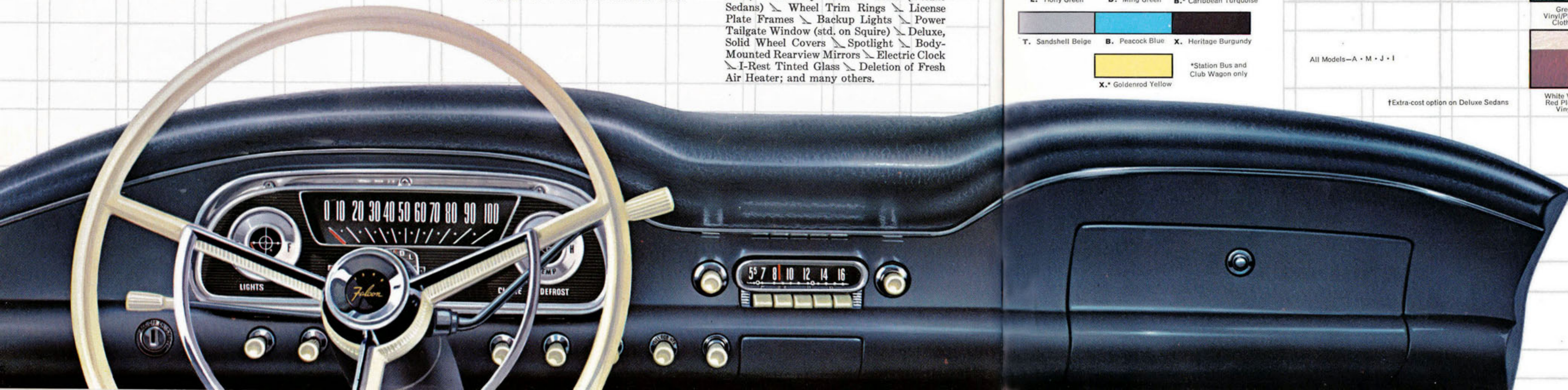

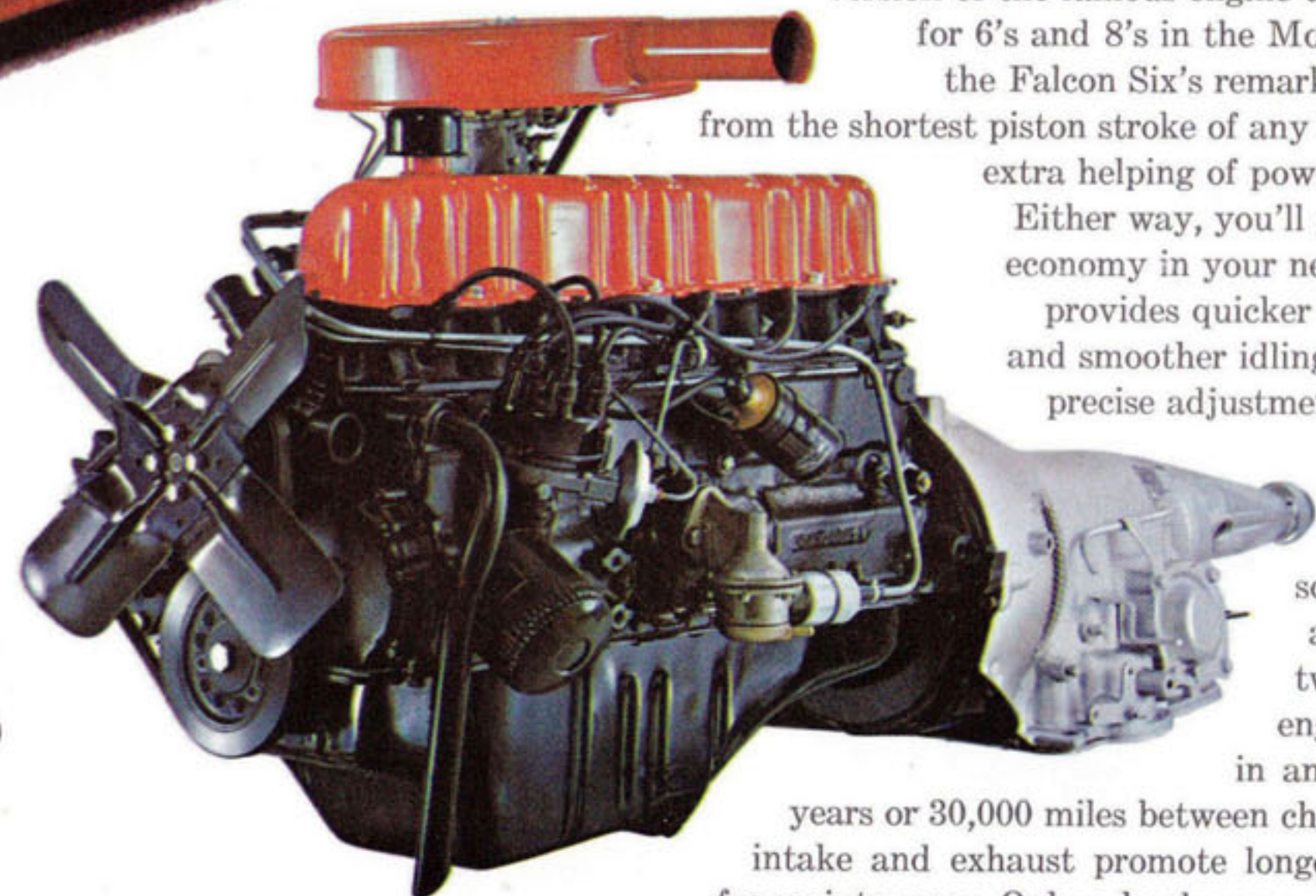
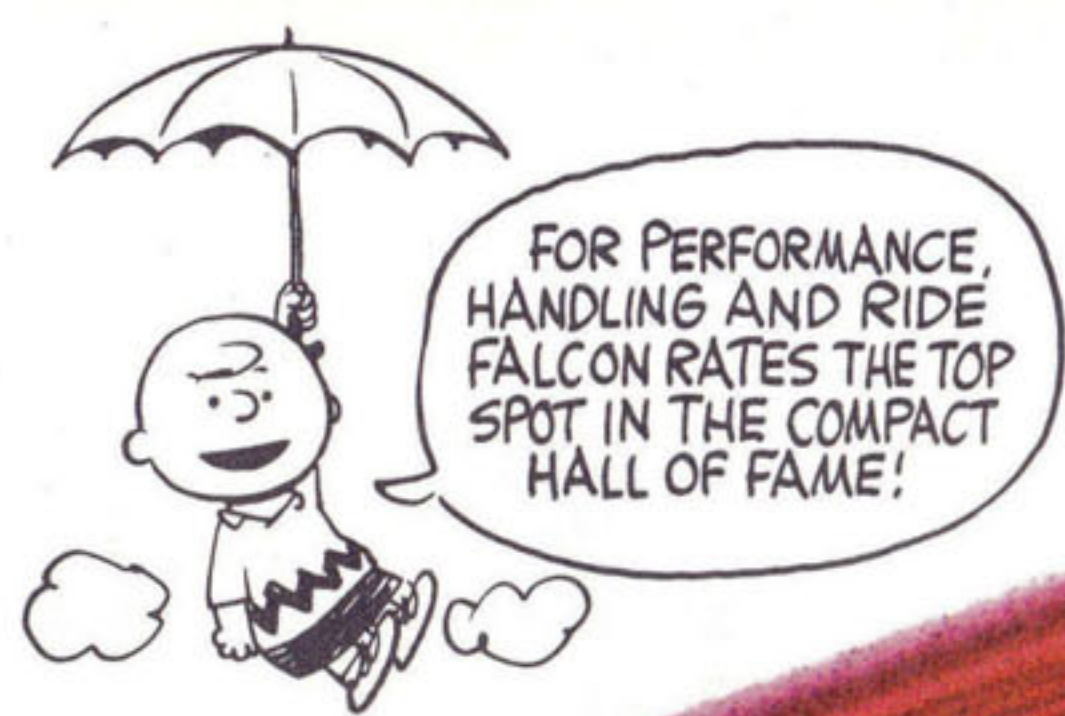

Under Falcon's Hood

Your choice of improved engines. You can go all out for gas savings and select the standard Falcon Six—an improved version of the famous engine that in '61 set a new all-time record for 6's and 8's in the Mobilgas Economy Run. (One reason: the Falcon Six's remarkable efficiency that comes, in part, from the shortest piston stroke of any U.S. compact!) Or, if you prefer an extra helping of power, choose Falcon's 170 Special Six. Either way, you'll get new thrift and all-round engine economy in your new Falcon. A brand-new carburetor provides quicker cold starts, more efficient warm-up and smoother idling. A new choke control allows more precise adjustment. All this makes Falcon *even more* thrifty with each gallon of regular.

Both Falcon engines offer greater oil savings, too. The super-screening Full-Flow Oil Filter (standard) helps you go 6,000 miles between oil changes.* Factory-installed engine coolant-antifreeze (with built-in anti-rust radiator protection) goes 2 years or 30,000 miles between changes. And free-turn valves on *both* intake and exhaust promote longer engine life as they reduce need for maintenance. Only a bank saves more than a Falcon!

*After first 1,000-mile change

Your choice of improved transmissions



FALCON 4-SPEED TRANSMISSION. A brand-new transmission choice with sports car feel and fun built in! Floor-mounted stick shift is right at your finger tips. All forward gears fully synchronized for quick, slick shifting up or down. Positive reverse gear lockout. (Avail. with both engines on all Falcons except Station Bus, Club Wagons.)



FALCON FORDOMATIC. Here's the finest "automatic" in the compact world! Two-speed drive range. Kick-down to low below 50 mph for sprightly passing. New vacuum-controlled throttle valve provides greater smoothness while eliminating need for periodic linkage adjustment. (Available with both engines on all Falcons except Station Bus, Club Wagons.)



FALCON 3-SPEED TRANSMISSION. This is Falcon's standard transmission on all models, and one of the most economical ever built! Folks who go all out for gas savings appreciate this feature most of all. They also like its shifting ease and smoothness, plus familiar, convenient shift lever on the steering column.

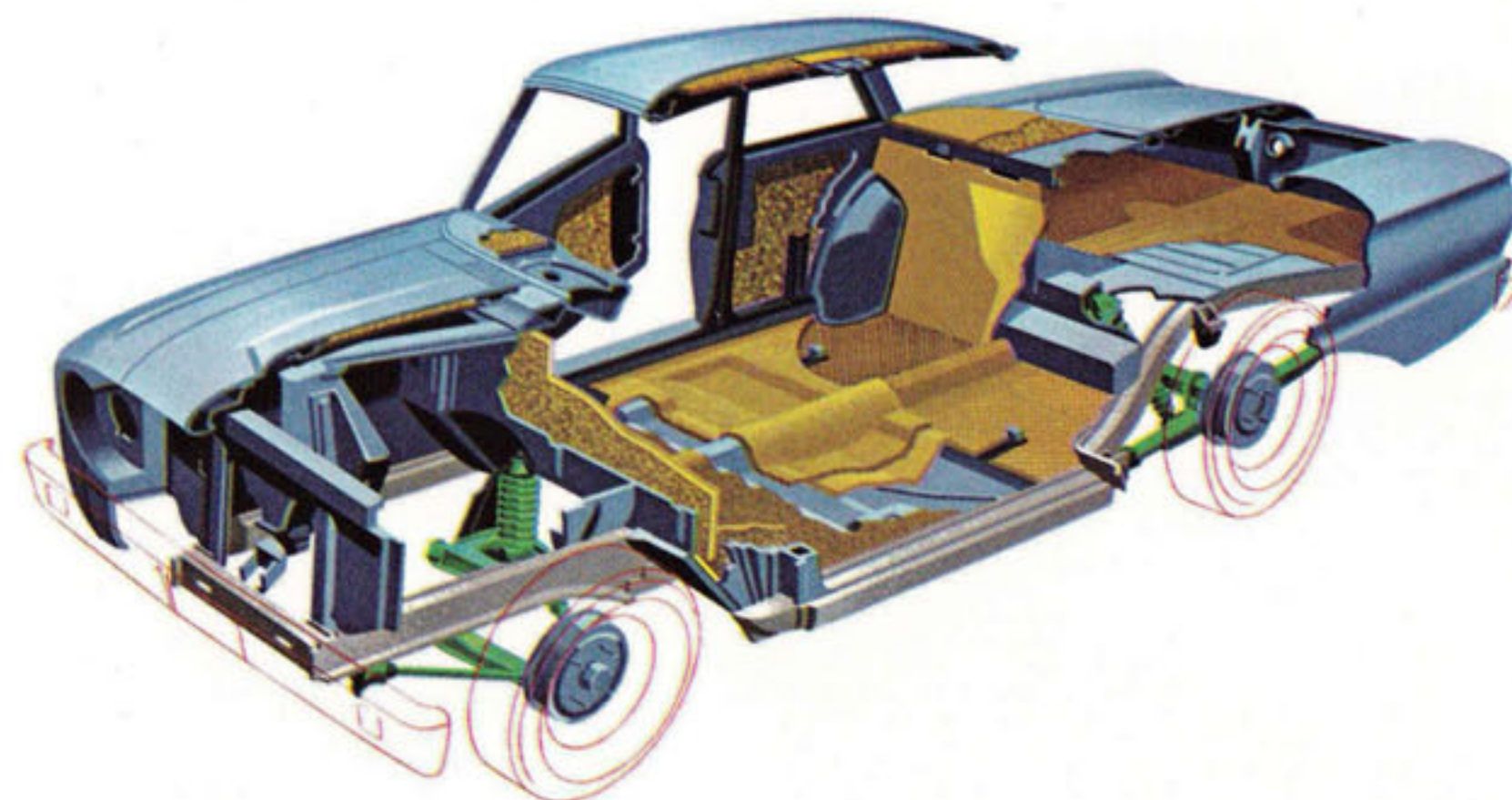

Single-unit Construction. Falcon's rock-solid, single-unit construction eliminates bulk, provides greater strength with least weight. This design efficiency also increases interior room for passengers and it greatly reduces squeak and rattle sources. *Body insulation* of many materials surrounds the passenger compartment with a sound-absorbing, noise-damping barrier. *Zinclud underbody members*—rocker panels and all vital underbody parts are galvanized for protection against rust and corrosion.

Big Brakes. Falcon brakes require so little pedal effort to produce sure, smooth, straight-line stops that you'll forget all about big-car power assists. Falcon brakes are "sized" to the braking job, too. Falcon wagons, being heavier vehicles, have bigger brakes (157 sq. in.) than Falcon sedans (131 sq. in.).

Big-Car Ride. Falcon's Ball-Joint front suspension smooths bumps and road faults, greatly reduces "nose-dive" in quick stops. Makes handling surer, safer. Variable-Rate rear suspension has 50-inch leaf springs mounted to the axle off-center, to resist rear end "squat" in starting. Teamed up, they make Falcon wonderfully able, stable and roadwise.

Best shape economy's ever been in—a Falcon engine!
Choose either the 85-hp Falcon Six, or optional 101-hp 170 Special Six (standard on Deluxe Club Wagon)

SPECIFICATIONS



The Ford Quality Control system, a Ford first, results in products of highest quality. All manufactured parts pass rigid dimensional, laboratory and durability tests. Quality Control teams also select cars from each shift at every assembly plant for an exhaustive search for any deviations from strict engineering specifications.

FALCON DESIGN: Welded, integral body and frame for quietness and high strength-weight ratio. Completely sealed and insulated. Roof cross braces at center on sedans and three roof cross braces on wagons give extra rigidity. Zinc-coated rocker panels and main underbody members for durability. Cowl-top ventilation. Wide Angle windshield with forward-slanting pillars. Large, wide-opening doors, with assist-type door checks and bronze-bushed hinges. Double-Grip door locks. Rear-mounted 14-gal. gas tank with Center-Fill fueling on sedans, left rear fender fuel fill on wagons, Station Bus and Club Wagons.

ENGINES: 85-hp Falcon Six—144-cu. in. displ.; 3.50" bore x 2.50" stroke; 8.7 to 1 comp. ratio; regular fuel; new low-silhouette unit-design carburetor; manual choke; oil capacity, with filter change, 4.5 qt.

101-hp Falcon 170 Special Six—170-cu. in. displ.; 3.50" bore x 2.94" stroke; 8.7 to 1 comp. ratio; regular fuel; new low-silhouette unit-design carburetor; manual choke; oil capacity, with filter change, 4.5 qt.

FEATURES: For greater economy and longer life, Falcon engines have short-stroke, low-friction design; Wedge-Type combustion chambers; Free-Turning overhead intake and exhaust valves; 3-ring aluminum-alloy pistons with full-chromed top ring; integral cylinder head and 6-port intake manifold; precision-molded crankshaft with four main bearings; rotor-type pump; Super-Filter dry-type air cleaner with reusable element (oil-bath air cleaner in Station Bus, Club Wagons); 6,000-mile high-capacity in-line fuel filter (4,000-mile filter in Station Bus, Club Wagons); vacuum-booster type fuel pump for more constant windshield wiper action; full-pressure lubrication system with Full-Flow disposable-type oil filter; pressurized cooling system with 190° Positive-Action thermostat; 2-yr. or 30,000-mile engine coolant-antifreeze (available—installed in production); 12-volt electrical system; weatherproof ignition; 18-mm. Turbo-Action spark plugs; 54-plate, 40 amp-hr battery; positive engagement starter; fully aluminized muffler. Engines electronically mass-balanced while operating under their own power for optimum smoothness.

CLUTCH AND MANUAL TRANSMISSIONS: Single cushion disc, dry-plate clutch for smooth engagement; aluminum housing; permanently lubricated ball-bearing type throw-out bearing. Face diameter is 8½". Total frictional area is 68.1 sq. in. **3-Speed Transmission** (std.) has fine-pitch helical gears treated for high strength and quietness with forged bronze synchronizers in 2nd and direct for smooth operation. Anti-friction bearings throughout. Standard "H" shift pattern with lever on steering column. Ratios (to 1): 1st 3.29, 2nd 1.75 (1.83 with 170 Special Six), direct 1.00, reverse 4.46; (Station Bus, Club Wagons: 1st 3.39, 2nd 1.97, direct 1.00, reverse 4.12). **4-Speed Transmission** (opt.) has floor-mounted "short stick" shift lever, with shift pattern on knob. All forward gears synchronized for fast, smooth shifting. Available with any Falcon model and engine except Station Bus, Club Wagons. Ratios (to 1): 1st 3.16, 2nd 2.21, 3rd 1.41, direct 1.00, reverse 3.35.

FORDOMATIC DRIVE (optional with any Falcon model and engine except Station Bus, Club Wagons): Features simplified design, lightweight cast-aluminum construction, new vacuum-controlled throttle valve for smoothness, minimum servicing. Torque converter

in combination with compound planetary gear set. Gear ratios (to 1): low 1.75, direct 1.00, reverse 1.50; converter (stall) 2.4. In "D" range gives brisk, smooth starts in low. Effective engine braking in "L" position. Air-cooled with 144 Six, air- and liquid-cooled with 170 Special Six. Selector lever and quadrant on steering column, sequence P-R-N-D-L.

REAR AXLE: Semi-floating type with offset hypoid gears. Induction-hardened forged shafts with permanently lubricated wheel bearings. **Axle Ratios** (to 1): **3-Speed Manual**—Sedans: 3.10 with std. Six, 3.20 with Special Six (3.50 opt., either engine)—All Wagons and Bus: 3.50 with both engines; 4.00 opt. with std. Six only. **4-Speed Manual**—Sedans: 3.10 with std. Six (3.50 opt.); 3.50 with Special Six (3.20 opt.)—Wagons: 3.50 with both engines; 4.00 opt. with std. Six only. **Fordomatic Drive**—Sedans and wagons: 3.50 with both engines; 4.00 opt. with std. Six on wagons.

FRONT SUSPENSION: Sedans and wagons—Angle-Poised Ball-Joint type with coil springs pivot-mounted on upper arms. Strut-stabilized lower arms. Threaded, permanently lubricated bushings in upper arms and rubber bushings in lower arms for softer ride. Built-in anti-dive control. Internally mounted hydraulic double-acting shock absorbers with rebound cutoff. Link-type, rubber-bushed ride stabilizer. Tapered roller wheel bearings. (Station Bus and Club Wagons have solid front axle and leaf springs.)

REAR SUSPENSION: Sedans and wagons—Longitudinal, semi-elliptic leaf springs with rubber-bushed supports and compression-type shackles, giving variable-rate characteristics for a softer, more levelized ride. Asymmetrical design with rear axle located forward from center of springs for anti-squat control on take-off. Full-length liners between leaves—no lubrication required. Diagonally mounted hydraulic double-acting shock absorbers. (Station Bus and Club Wagons have front and rear leaf springs similar to the type described.)

STEERING: Magic-Circle low-friction recirculating-ball type steering gear provides easy handling. Anti-friction bearings throughout. Over-all steering ratio—sedans and wagons: 27 to 1; Station Bus and Club Wagons: 20 to 1. Turning diameter—sedans and wagons: 38.8 ft.; Station Bus and Club Wagons: 34.8 ft.

BRAKES: Double-sealed, self-energizing hydraulic with composite drums. Diameter, front and rear: 9 in. on sedans and wagons, 10 in. on Station Bus and Club Wagons. Molded linings for long life and fade resistance. Total lining area 131.0 sq. in. on sedans, 157 sq. in. on wagons; 168 sq. in. on Station Bus and Club Wagons.

TIRES: Soft-Tread design, black, tubeless with Tyrex Rayon cord, safety-type rims. Sedans—6.00 x 13 on 4" rims; All Wagons—6.50 x 13 on 4½" rims; (optional 7.00 x 13 6-ply required with 2nd, or 2nd and 3rd seat options in Station Bus, Club Wagons). Spare wheel and tire location: Sedans—luggage compartment; Wagons, Station Bus and Club Wagons—cargo area behind right-hand wheelhousing.

CURB WEIGHTS (approx.): Sedans—2370 lb. Tudor, 2410 lb. Fordor, 2450 lb. Sports Futura; Wagons—2670 lb. Tudor, 2700 lb. Fordor, 2740 lb. Falcon Squire. Station Bus 2800 lb., Deluxe Club Wagon 3060 lb. For dimensions see illustrations at right.

PRICES: All Optional Equipment and Accessories, illustrated or referred to as options, optional or available in this catalog are at extra cost. For the price of the Falcon with the equipment you desire, see your Ford Dealer.

Comparative information in this catalog was obtained from authoritative sources, but is not guaranteed. The specifications contained herein were in effect at the time this catalog was approved for printing. Ford Division of Ford Motor Company reserves the right to discontinue models at any time, or change prices, specifications or designs without notice and without incurring obligation.

PRODUCTS OF  MOTOR COMPANY

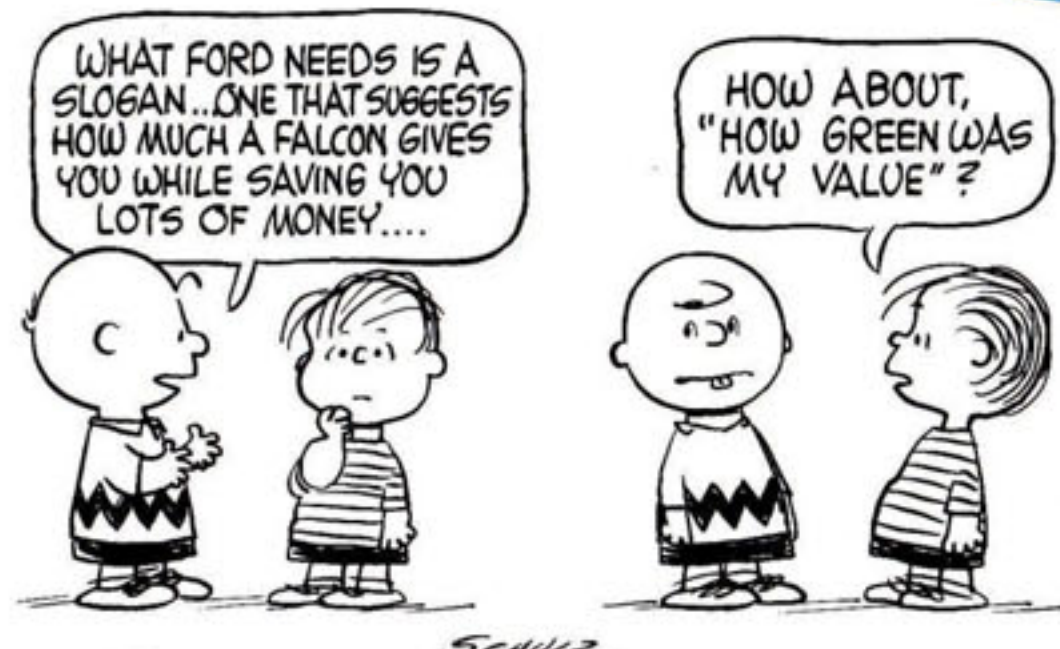

SCHULZ

Your Friendly FORD Dealer

Sedan and Wagon Dimensions

