

NEW F-650/F-750 SUPER DUTY®

2011



commtruck.ford.com





F-750 XLT Regular Cab in Bright Red with available and aftermarket equipment

BIG CAPABILITY for your TOUGHEST JOBS.

The New 2011 F-650/F-750 Super Duty.®

Maneuverability. **POWERTRAIN FLEXIBILITY.** Massive axle capacities. **AVAILABLE CLEAN CA.** You can count on these new medium-duty Ford trucks to deliver – and then some. For 2011, they're packed with **MORE VALUABLE STANDARDS** like synthetic fluid on all Allison Transmission™ automatics, plus an all-new instrument panel with integrated upfitter switches. GVWRs go from 20,160 to 37,000 lbs. The proven **CUMMINS® ISB 6.7L TURBO DIESEL** offers 10 ratings – up to 360 horsepower and 800 lb.-ft. of torque. Front axle ratings go up to 14,000 lbs. And rear axles go as high as 23,000 lbs. Regular Cab, SuperCab or Crew Cab, there's a new 2011 F-650/F-750 just right for you.

Vehicles throughout this PDF may be shown with optional and aftermarket upfit equipment.

2011
NEW F-650/F-750 SUPER DUTY®

commtruck.ford.com



Now with **MORE WAYS** to
WORK HARDER.



F-750 XLT Regular Cab in Oxford White with available and aftermarket equipment

New and improved – inside and underneath.

The **ALL-NEW INTERIOR** starts with an **ALL-NEW INSTRUMENT PANEL DESIGN** that puts important controls within easy reach, while **NEW SEATING OPTIONS** help increase comfort on those extra-long days in the saddle. Underneath, **NEW EQUIPMENT OPTIONS** like your choice of axles from Dana Spicer® and Meritor®, plus new emissions/exhaust setups help make it easy to build **YOUR TRUCK, YOUR WAY.**

NEW CHOICES

- 10 engine ratings: up to 360 horsepower and 800 lb.-ft. of torque
- 2 Diesel Exhaust Fluid (DEF) tank sizes to accommodate Clean CA choices
- Available 35-gal. fuel tank and 5-gal. DEF tank under cab on driver's side – clean CA
- Available 40/20/40 split front seat
- Available 6-way power, heated, leather-trimmed driver and front-passenger seats
- Available overhead gauge pod
- Available power, heated trailer tow mirrors
- Available Ford Work Solutions™⁴

IMPROVED STANDARDS

- Synthetic fluid on Allison Transmissions™
- Extended-life engine coolant
- All-new interior design including new front seats with armrests/cupholders
- New electronically controlled climate system
- 4 upfitter switches on instrument panel
- Cruise control switches on steering wheel
- 8-in. blind spot mirrors (XLT)
- Radio with MP3 capability and auxiliary audio input (XLT)
- Overhead console with dual sunglasses bins and map-reading lights (XLT)
- Floor-mounted mini-console with cupholders
- 185-amp alternator

⁴Available early 2011.

2011
NEW F-650/F-750 SUPER DUTY®

commtruck.ford.com



Versatile to make UPFITTING EASY.

A 35 FUEL TANK SETUPS are available. Deep tanks can help you go the distance. Shallow tanks provide up to 19 inches of ground clearance. There's even a 65-gallon between-the-rails fuel tank that mounts behind the rear axle. It's your upfit – your call.

B BATTERY BOX LOCATION OPTIONS vary in combination with exhaust and fuel tank packaging. Choose from 2- or 3-battery setups with dual 625 CCA, triple 625 CCA, dual 900 CCA or triple 900 CCA. Or go with a temporary battery box for final placement that works best with your upfit.

C PROTECTIVE AIR TANK POSITIONING also results in cleaner CAs. The tanks for the available air brake system are packaged adjacent to the frame rails and under the cab on every cab style.

D NEW POWERSCOPE™ TRAILER TOW MIRRORS adjust, fold and telescope at the touch of a switch. This class-exclusive option includes integrated clearance lamps and turn signals, plus heated glass with manually adjustable integrated blind spot mirrors.

■ **NEW DANA SPICER S140 REAR AXLES**, standard on F-650 straight-frame models, are over 100 lbs. lighter than last year's offerings. They utilize GenTech™ gear sets for quiet operation and synthetic lube for long-lasting durability.

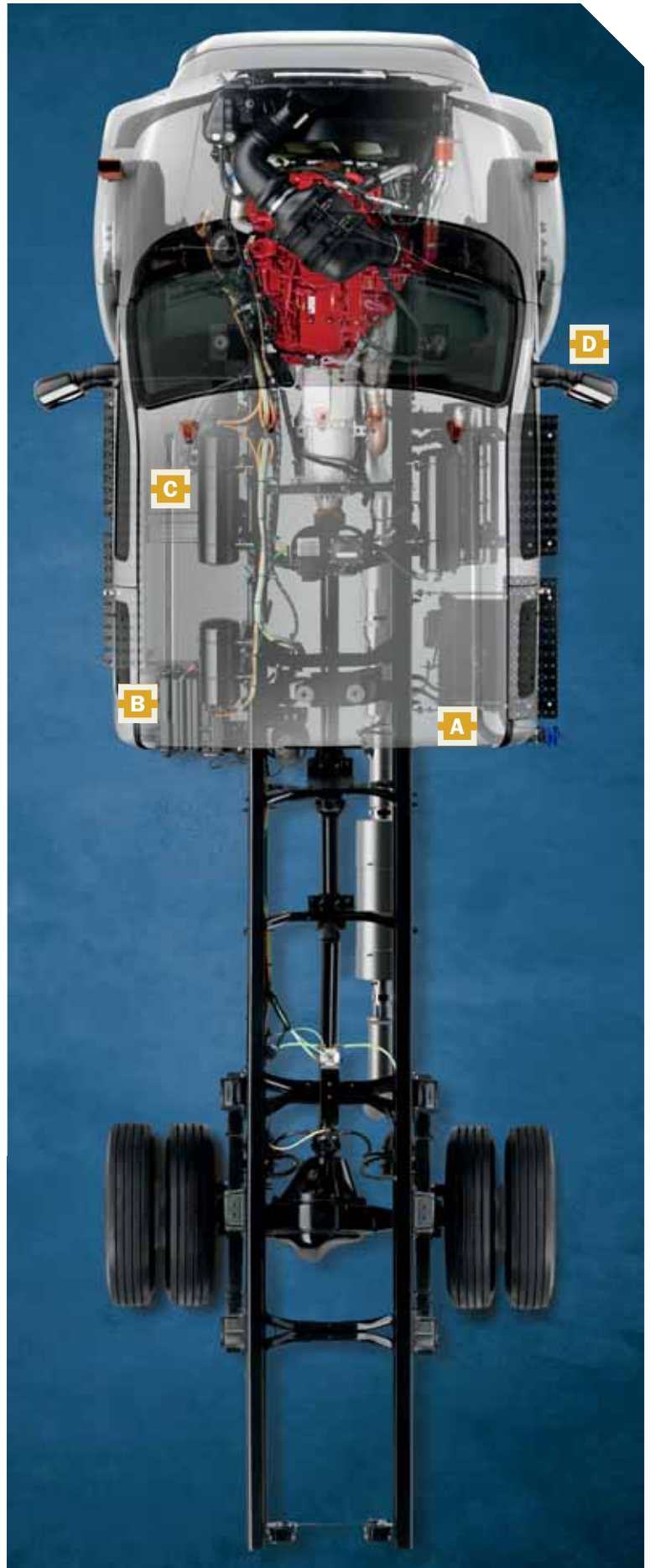

2011
NEW F-650/F-750 SUPER DUTY®

commtruck.ford.com



New

AXLE, EXHAUST AND TANK CHOICES.

These trucks are all about what you make them. And Ford is all about making upfits easy on you. Frame-rail spacing remains the industry standard at 34 inches. New for 2011, you get more axle options from trusted names including **MERITOR®** and **DANA SPICER®**. Several new emissions/exhaust setups and Diesel Exhaust Fluid (DEF) tank solutions help facilitate a wide variety of upfits. Over 30 clean CA offerings range from 60 inches to 186 inches. Variety. It's what makes these Built Ford Tough® trucks some of the **MOST VERSATILE UPFIT VEHICLES** on the road today.



NEW HORIZONTAL EXHAUST system exits the tailpipe in front of the rear axle, or over the top of it depending on your wheelbase choice.



NEW UNDER-CAB HORIZONTAL SWITCHBACK exhaust system is another option Ford offers to help make your upfits easy and cost-effective.



NEW UNDER-CAB VERTICAL SWITCHBACK exhaust system is a compact option with pipe routing similar to the "big rigs" exiting at the top of the cab on the passenger side.

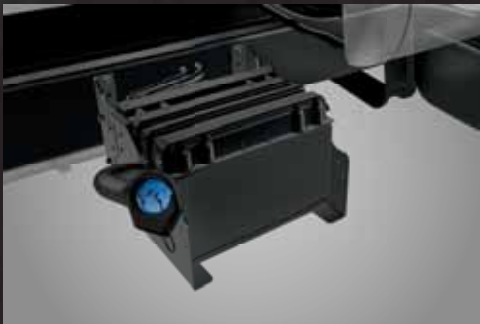

NEW 10-GAL. DEF TANK option mounts outside the frame rails, behind the cab on the passenger side (Regular Cab/SuperCab).



CREW CAB 10-GAL. DEF TANK option mounts under the cab on the passenger side.



NEW 35-GAL. FUEL TANK and **5-GAL. DEF TANK** option mounts under the cab on the driver's side for a Clean CA on Regular Cab models.

2011
NEW F-650/F-750 SUPER DUTY®

commtruck.ford.com



CUMMINS® ISB 6.7L ENGINE PERFORMANCE

Find your perfect match: 10 sets of ratings range from 200 hp and 520 lb.-ft. of torque all the way up to 360 hp¹ and 800 lb.-ft. of torque (shown below).

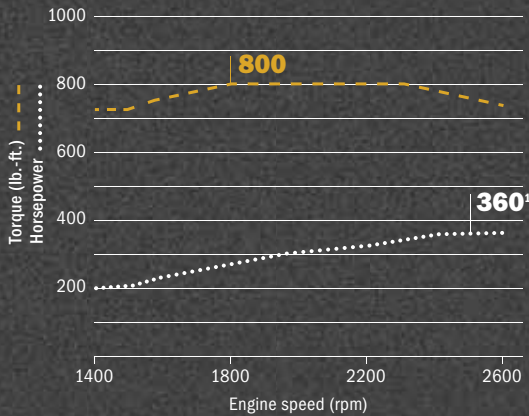

- A INLINE 6-CYLINDER DESIGN** uses stiff cast-iron engine block and head for maximum strength and long-lasting durability.
- B COOLED EXHAUST GAS RECIRCULATION** system lowers combustion temperatures to help optimize fuel efficiency and emissions.
- C CUMMINS VARIABLE GEOMETRY TURBOCHARGER (VGT™)** features a durable sliding-nozzle design and electric actuation for infinite adjustment with quick response. An available integrated exhaust brake (not shown) contributes to slowing and stopping power.
- D HIGH-PRESSURE COMMON-RAIL FUEL INJECTION** system uses precise control to help deliver an optimum balance of performance, emissions control and fuel efficiency across the entire operating range.
- NEW ALTERNATOR LINEUP** starts with a larger standard 185-amp Leece-Neville model. More powerful 220-amp and 320-amp alternators are also available on all trucks.



¹Rating is restricted to emergency vehicle/recreational vehicle applications only. See your Ford Dealer for details.

Up to
360 HP &
800 LB.-FT. of
MAX. TORQUE.



A

B

C

D

Cummins

Engine appearance differs when installed in vehicle.

Proven. Dependable. Cummins.

The standard engine for 2011 is the venerable **ISB 6.7L**. It features the latest Cummins technology, including full-authority electronic controls, a high-pressure common-rail fuel-injection system, 24-valve design, the patented VGT turbocharger, a particulate filter and more. Excellent power-to-weight ratios help it deliver **OUTSTANDING FUEL ECONOMY** as it delivers every load. The 6.7L comes in your choice of **10 HORSEPOWER AND TORQUE RATINGS**, paired with one of a dozen durable, capable transmissions. Automatics from Allison Transmission!™ Manuals from Fuller® and Dana Spicer.® With all these options, it's easy to build the perfect truck for your line of work.

2011
NEW F-650/F-750 SUPER DUTY®

commtruck.ford.com





F-650 XLT Crew Cab in Black Two-Tone Leather trim with available equipment

A whole **NEW LEVEL** of
COMFORT and
CONTROL.

All-new interior with redesigned instrument panel.



NEW OVERHEAD GAUGE POD places your optional gauges and auxiliary switches front and center. Possibilities include: hour meter gauge, voltmeter gauge, differential lock switch, air-suspension dump switch, transmission temperature gauge, exhaust brake switch and 2-speed axle switch.



NEW 40/20/40 SPLIT FRONT SEAT option includes an armrest with built-in cupholders for added convenience.



New for 2011, the available **INTERNET-CAPABLE IN-DASH COMPUTER**¹ features Garmin® Navigation, hands-free calling, and a convenient touch screen with wireless keyboard. From spreadsheets to surfing the web, it helps tackle your workload and ease your day.² Take advantage of the available **CREW CHIEF™** fleet management system¹ from Microlise® to track your vehicles and keep them in shape with optional diagnostic/maintenance reports.² This beneficial system can be accessed from the Ford Work Solutions™ in-dash computer, or any computer connected to the Internet.

Ford Work Solutions include Ford Licensed Accessories. See dealer for limited warranty details.

¹Available early 2011. Some features are unavailable while driving. ²Service fee required.

2011 **NEW F-650/F-750 SUPER DUTY®**

commtruck.ford.com



XL & XLT



F-650 XLT Crew Cab in Black Two-Tone Leather trim with available equipment

INTERIOR



Steel Gray HD Vinyl
Standard on XL/Optional on XLT



Steel Gray Cloth
Standard on XLT/Optional on XL



Black Two-Tone Leather
Optional on XLT

STANDARD XL TRIM PACKAGE

- Includes molded cloth headliner
- Right- and left-hand coat hooks
- Sun visors with passenger side mirror
- Overhead console with dual sunglasses bins and integral map lights (SuperCab/Crew Cab)
- High-back Steel Gray HD vinyl 40% width driver's seat with head restraint
- 2-person Steel Gray HD vinyl 70% width front-passenger seat with fold-down armrest and cupholders
- 2nd-row Steel Gray HD vinyl 60/40 split bench seat (SuperCab/Crew Cab)
- Door-trim panels with standard armrests
- Manual air conditioning
- Charcoal Black air registers
- West Coast-style mirrors
- AM/FM stereo with clock and 2 speakers

OPTIONAL XLT TRIM PACKAGE

- Includes molded cloth headliner
- Right- and left-hand coat hooks
- Sun visors with passenger side mirror
- Overhead console with dual sunglasses bins and integral map lights
- High-back Steel Gray cloth 40% width driver's seat with head restraint
- 2-person Steel Gray cloth 70% width front-passenger seat with fold-down armrest and cupholders
- 2nd-row Steel Gray cloth 60/40 split bench seat (SuperCab/Crew Cab)
- Molded door-trim panels with upper and lower map pockets with soft-foamed armrest
- Manual air conditioning
- Chrome-trimmed air registers
- West Coast-style mirrors with 8-in. diameter convex blind spot mirrors
- Power Equipment Group includes power front windows (Regular Cab/SuperCab), power front and rear windows (Crew Cab), and power door locks
- Front tow hooks
- AM/FM stereo/single-CD player with MP3 capability, clock and 2 speakers (Regular Cab) or 4 speakers (SuperCab/Crew Cab)
- Dash-mounted audio input jack









Colors are representative only.
See your dealer for actual paint/trim options.

2011
NEW F-650/F-750 SUPER DUTY®

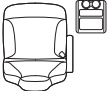
commtruck.ford.com





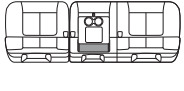



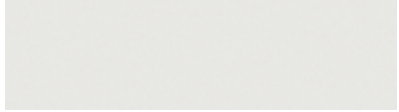

SEATING

		SEAT SUSPENSION SYSTEM	SEATING POSITION AVAILABILITY	XL ¹	XLT ²
STANDARD FRONT SEATS					
	40% width high-back captain's chair with integrated head restraint, fore/aft adjustment, reclining, armrest with mini-console	Fixed-spring	Driver	●	●
	70% width 2-person, intermediate-back folding, outboard-position integrated head restraint, fold-down armrest with cupholders	Fixed-spring	Center/Passenger	●	●
OPTIONAL FRONT SEATS					
	40/20/40 split front, full-width, fore/aft adjustment, reclining, low-back with adjustable head restraints, driver's seat includes manual lumbar, fixed center seat includes tray and cupholders	Fixed-spring	Driver/Center/Passenger	○	○
	Air suspension with integral pump high-back bucket with integrated head restraint, includes armrest with mini-console (Regular Cab deletes coat hooks on XL; Regular Cab and Crew Cab only)	Air suspension with integrated air compressor ³	Driver	○	○
	Full air-ride high-back bucket with integrated head restraint, dumping/full reclining, armrest with mini-console (Regular Cab and Crew Cab only)	Air-ride ⁴ /Fixed-spring	Driver or Driver/Passenger	○	○
	Full air-ride high-back buckets with integrated head restraints, dumping/full reclining, fore/aft isolation armrests (Regular Cab and Crew Cab only)	Air-ride/Fixed-spring	Driver/Passenger	○	○
	Air suspension with integral pump high-back bucket seats with integrated head restraints, armrests (Regular Cab and Crew Cab only)	Air suspension with integrated air compressor ³	Driver/Passenger	○	○
	Leather-trimmed high-back front captain's chairs with 6-way power adjust, reclining, integrated head restraints, heated driver/outboard passenger, integrated armrest	Fixed-spring	Driver/Center/Passenger	—	○
STANDARD REAR SEATS⁵					
	60/40 split 3-person rear bench, full-width, fold-up, converts to loadfloor (SuperCab)	High-density foam	Rear bench	●	●
	60/40 split 3-person full-size rear bench, full-width, folding back (Crew Cab)	Fixed-spring	Rear bench	●	●

● Standard ○ Optional — Not available

¹Steel Gray HD Vinyl standard, Steel Gray Cloth optional. ²Steel Gray Cloth standard, Steel Gray HD Vinyl optional. ³Available only with Hydraulic Brake System option. ⁴Requires air brakes or air compressor option. ⁵Rear seat is vinyl with leather-trimmed front seats on SuperCab.

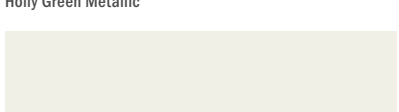
EXTERIOR

	Oxford White
	Bright Red
	True Blue Metallic
	Bold Yellow
	Omaha Orange
	School Bus Yellow
	Holly Green Metallic
	Winter White
	Black

EXTERIOR COLORS INTERIOR COLORS

Oxford White	▲ ● ■
Bright Red	▲ ● ■
True Blue Metallic	▲ ● ■
Bold Yellow	▲ ● ■
Omaha Orange	▲ ● ■
School Bus Yellow	▲ ● ■
Holly Green Metallic	▲ ● ■
Winter White	▲ ● ■
Black	▲ ● ■

INTERIORS: ▲ Steel Gray HD Vinyl

● Steel Gray Cloth ■ Black Two-Tone Leather

2011

NEW F-650/F-750 SUPER DUTY®

commtruck.ford.com



MODELS

F-650 PRO-LOADER®

MAXIMUM CAPABILITIES¹

GVWR: 26,000 lbs.

Front axle: 8,500 lbs. Meritor MFS-08-153B I-Beam (standard)

Rear axle: 13,500 lbs. Meritor MS-17-14X-30LF single-speed (standard)

EQUIPMENT CONFIGURATIONS

Engines: Cummins® ISB 6.7L Turbo Diesel

Driveline: 4x2 Dual Rear Wheel only

Bodies: Regular Cab, SuperCab, Crew Cab

Trim Series: XL, XLT

F-650²

MAXIMUM CAPABILITIES¹

GVWR: 29,000 lbs.

Front axle: 8,500 lbs. Meritor MFS-08-153B I-Beam (standard)

Rear axle: 17,500 lbs. Dana Spicer® S17-140 single-speed (standard)

EQUIPMENT CONFIGURATIONS

Engines: Cummins ISB 6.7L Turbo Diesel

Driveline: 4x2 Dual Rear Wheel only

Bodies: Regular Cab, SuperCab, Crew Cab

Trim Series: XL, XLT

F-750

MAXIMUM CAPABILITIES¹

GVWR: 37,000 lbs.

Front axle: 10,000 lbs. Meritor MFS-10-122A I-Beam (standard)

Rear axle: 21,000 lbs. Meritor MS-21-14X-3DLF single-speed (standard)

EQUIPMENT CONFIGURATIONS

Engines: Cummins ISB 6.7L Turbo Diesel

Driveline: 4x2 Dual Rear Wheel only

Bodies: Regular Cab, SuperCab, Crew Cab

Trim Series: XL, XLT

STANDARD FEATURES



MECHANICAL

Cummins ISB 6.7L Turbo Diesel I-6 engine

10-gal. DEF tank

12-volt, Delco Remy 38 MT Type 300 starting motor

45-gal. single, rectangular steel, shallow fuel tank (13-in. deep), frame mounted on left side

185-amp, 12-volt, Leece-Neville, pad-mounted alternator

625 Cold Cranking Amps (CCA), 12-volt battery (2 for a total of 1,250 CCA)

Allison Transmission™ with synthetic transmission oil

Battery box at right-hand frame rail under cab step

BorgWarner fan clutch

Bosch DDSA-type parking brake, 12-in. x 3-in., rear axle-mounted

Cross-flow 717 sq.-in. aluminum radiator with in-tank transmission fluid cooler

Donaldson® single element air cleaner with restriction indicator

Emergency flashers

Engine coolant with red extended-life -40°F

freeze-protection rating

Exhaust — In-line single, horizontal, diesel particulate filter assembly; frame-mounted right side back of cab, single SCR assembly; frame-mounted right side back of cab, horizontal tailpipe; exits behind rear wheels right side

Fleetguard® fuel/water separator with electric-type heater and primer pump

Frame-mounted body-builder wiring at back of cab

Front double-acting shock absorbers

Meritor® Quadrauc™ 4-channel Anti-Lock Brake System (ABS)

Parking brake control lever right of driver

Rectangular halogen sealed-beam headlamps (includes front-side marker lamps with reflectors)

SAE blade-type fuses

Spicer SPL100 driveshaft

STEMCO® wheel seals with Guardian® oil (front axle), synthetic oil (rear axle)

Taillamps (2) with integrated stop, turn signal, backup and license plate

Vari-rate suspension with multi-leaf rear springs

Interior

Auxiliary powerpoints (2)

Black vinyl 2-spoke steering wheel (15.5-in. diameter with 8,500-lb. front axle; 17.5-in. diameter with 10,000-lb. front axle)

Black vinyl floor covering

Coat hooks (2)

INTERIOR

Air registers with positive shut-off

Assist handle on interior A pillars

Auxiliary powerpoints (2)

Black molded-in-color scuff plates

Black vinyl 2-spoke steering wheel (15.5-in. diameter with 8,500-lb. front axle; 17.5-in. diameter with 10,000-lb. front axle)

Black vinyl floor covering

Coat hooks (2)

Emergency flashers

Engine coolant with red extended-life -40°F

freeze-protection rating

Exhaust — In-line single, horizontal, diesel particulate filter assembly; frame-mounted right side back of cab, single SCR assembly; frame-mounted right side back of cab, horizontal tailpipe; exits behind rear wheels right side

Fleetguard® fuel/water separator with electric-type heater and primer pump

Frame-mounted body-builder wiring at back of cab

Front double-acting shock absorbers

Meritor® Quadrauc™ 4-channel Anti-Lock Brake System (ABS)

Parking brake control lever right of driver

Rectangular halogen sealed-beam headlamps (includes front-side marker lamps with reflectors)

SAE blade-type fuses

Spicer SPL100 driveshaft

STEMCO® wheel seals with Guardian® oil (front axle), synthetic oil (rear axle)

Taillamps (2) with integrated stop, turn signal, backup and license plate

Vari-rate suspension with multi-leaf rear springs

INTERIOR (continued)

Cruise control with steering wheel-mounted controls

Cupholders on 70% front-passenger seat armrest

Driver and front-passenger cloth sun visors

Front-mounted overhead console with dual sunglasses bins and integral front map lights (all SuperCab/Crew Cab, XLT Regular Cab)

Gauge cluster with electronic speedometer (mph/kph), oil pressure, coolant temperature, DEF gauge, fuel gauge, tachometer, indicator lights, enhanced 3-button message center with odometer, trip odometer, distance to empty for fuel, average fuel economy and warning messages

Left-/right-hand front window demisters

Manual air conditioning with integral heater and defroster

Multifunction, self-canceling turn signal switch

Rear-mounted dome lamp with integral map lights (Regular Cab/Crew Cab only)

Tilt steering column

Upfitter switches (4) located in center IP with connector access located in engine compartment

EXTERIOR

Assist handle on exterior B pillars (Regular Cab)

Assist handle on exterior rear doors (SuperCab)

Assist handle on exterior C pillars (Crew Cab)

Auxiliary convex mirrors (2), stainless steel, 8-in. diameter, mounted below primary mirrors (XLT only; available only with dual stainless steel West Coast-style mirrors)

Chrome grille (includes chrome headlamp bezels)

Dual electric horn

Dual rectangular mirrors, 7.5-in. x 16.5-in. stainless steel, West Coast-style, 102-in.-wide spacing

Fixed rear window

Frame-mounted front-end-tilting fiberglass hood and fenders assembly with torsion-bar assist (includes integrated noise shield, inner splash shields and mud flaps)

Full-width, chrome-plated steel front bumper

Laminated windshield glass, solar-tinted all around

Roof marker/clearance lamps (5)

Windshield wipers — 2-speed intermittent with washer

SAFETY & SECURITY

Belt-Minder® front safety belt reminder (chime and flashing warning light on instrument panel if driver's safety belt isn't buckled)

Color-keyed safety belts with fixed D-rings at all positions (Regular Cab)³

Color-keyed safety belts with front-seat adjustable D-rings (SuperCab/Crew Cab)³

Allison Transmission is a trademark of Allison Transmission, Inc.

Cummins is a registered trademark of Cummins Inc.

Spicer is a registered trademark of Dana Limited.

Meritor is a registered trademark of Meritor Technology, Inc.

VGT is a trademark of Cummins Inc.

Fuller is a registered trademark of Eaton Corporation.

Garmin is a registered trademark of Garmin Ltd.

Microlise is a registered trademark of Microlise Limited.

Donaldson is a registered trademark of Donaldson Company, Inc.

Fleetguard is a registered trademark of Fleetguard, Inc.

Quadrauc is a trademark of Meritor Technology, Inc.

STEMCO is a registered trademark of STEMCO LP.

Guardian is a registered trademark of STEMCO LP.

Bendix is a registered trademark of Honeywell International Inc.

Windows is a registered trademark of Microsoft Corporation.

¹When properly equipped. ²Badged as Pro Loader when equipped with 19.5-in. wheels. ³Always wear your safety belt and follow airbag warning label instructions. ⁴Available early 2011.

2011
NEW F-650/F-750 SUPER DUTY®

commtruck.ford.com



OPTIONAL FEATURES

AXLE & SUSPENSION – FRONT

Emgard® SAE 50 Synthetic Manual Transmission Lubricant
Rubber auxiliary springs

AXLE & SUSPENSION – REAR

Air suspension (requires air brake or compressor)
Air suspension dump valve with driver-controlled pressure release in Overhead Pod
Air suspension leveling valve
Double-acting shock absorbers
Emgard® EP 75W-90 Synthetic Gear Lubricant

BRAKES & BRAKE EQUIPMENT

Air brake system – Meritor Q-plus with ABS, 4-channel
Air brake system with traction control – Automatic transmission (traction control switch in Overhead Pod)
Air brake system – Straight truck use only
Air brake system – Tractor use only (Regular Cab/SuperCab only)
Hydraulic brake system with traction control – Automatic transmission (brake system control in Overhead Pod)
Air compressor – Cummins engines: 18.7-CFM capacity
Air compressor – Cummins engines: 18.7-CFM capacity, includes direct-reading air pressure gauge and one air tank 1,742 cu.-in. (requires hydraulic brake system)
Air dryer – Bendix® AD/IP with heater: mounted on left frame rail back of cab (restrictions apply)
Automatic drain valve (Bendix DV-2) with heater
Brake chambers spring – Relocated to rear of rear axle for maximum ground clearance (n/a on Pro Loader)
Powered parking brake – Bosch DSSA type, 12-in. x 3-in., rear axle-mounted (requires traction control)

TRAILER CONNECTIONS

4-wheel trailer Air Brake Package (n/a on Pro Loader)
7-way trailer connection socket

FUEL TANKS

Steel – Shallow (13-in. depth)
Steel – Deep (16-in. depth)
Steel – 65-gal. between the rail, aft rear axle

ENGINE EQUIPMENT

Engine block heater – 750-watt
Engine exhaust brake – Variable Geometry Turbocharger (VGT™) (activation switch is in Overhead Pod)
CARB-compliant vehicle (receives clean idle label on hood)
CARB-exempt vehicle (no label)
Non-CARB-compliant vehicle (41-state certification)

DRIVELINE & CLUTCHES

Clutch – Fuller® 14-in., single-plate, adjustment-free
Clutch – Fuller 14-in., 2-plate, adjustment-free
Emgard® SAE 50 Synthetic Manual Transmission Lubricant
Spicer SPL 140 driveshaft

EXHAUST

5-gal. DEF tank – Mounted left frame rail under cab for clean CA on Regular Cab/SuperCab only)
10-gal. DEF tank – Mounted right frame rail aft of cab on Regular Cab/SuperCab, under cab on Crew Cab
In-line single, horizontal, diesel particulate filter assembly; frame-mounted right side back of cab, single horizontal SCR assembly; frame-mounted right side back of cab, includes horizontal tailpipe, exits front of rear wheels on right side (over 221-in. wheelbase only)
Switchback single, horizontal, diesel particulate filter assembly; frame-mounted outside right rail under cab, includes single horizontal SCR assembly; frame-mounted outside right rail under cab, horizontal tailpipe right-side outlet (available on all wheelbases, requires left-side or temporary battery mount)
Switchback single, horizontal, diesel particulate filter assembly; frame-mounted outside right rail under cab, includes single horizontal SCR assembly; frame-mounted outside right rail under cab, horizontal tailpipe left-side outlet (available on all wheelbases, requires left-side or temporary battery mount)
Switchback single, horizontal, diesel particulate filter assembly; frame-mounted outside right rail under cab, includes single horizontal SCR assembly; frame-mounted outside right rail under cab, right-side-mounted vertical tailpipe and guard (available on all wheelbases, requires left-side or temporary battery mount)
Turn-back outlet for vertical exhaust only

ELECTRICAL

Alternator – 220-amp, 12-volt Leece-Neville
Alternator – 320-amp, 12-volt Leece-Neville
Batteries – 900 CCA, 12-volt (2 for a total of 1,800 CCA)
Batteries – 625 CCA, 12-volt (3 for a total of 1,875 CCA)
Batteries – 900 CCA, 12-volt (3 for a total of 2,700 CCA)
Battery – Temporary mount (dual 625 CCA or dual 900 CCA only)
Body-builder special wiring harness
Body-builder wiring to end of frame
Daytime running lamps
Electric, 102-decibel backup alarm
Fender-mounted, front- and rear-facing turn signal lamps
Remote-mounted jump-start stud
Stop, turn, tail and backup lamps (includes separate rear reflectors; does not include power module or rubber mount)
Taillamp delete (does not omit cable to end of frame)

CAB EQUIPMENT – EXTERIOR

Front bolt-on-type frame extension, 20-in. without crossmember (requires fixed grille, swept-back front bumper or front bumper delete, n/a on Pro Loader)
Front bumper – Full-width, painted-steel, Dark Shadow Gray color (n/a on XLT)
Front bumper – Swept-back, painted-steel, Dark Shadow Gray color (requires frame extension)
Front bumper delete
Front license plate holder with upper and lower mounting-plate hardware
Front tow hooks (2) – Frame-mounted inside rail (included on XLT)
Grille – Dark Shadow Gray
Grille – Fixed, Dark Shadow Gray

CAB EQUIPMENT – EXTERIOR (continued)

Horn – Air, black, single trumpet, mounted on frame rail back of bumper
Mirrors – Auxiliary convex (2), stainless steel, 8-in. diameter, mounted below primary mirrors (included on XLT)
Mirrors – Dual stainless steel with heated and lighted heads, rectangular, 7.5-in. x 16.5-in., West Coast-style, 102-in.-wide spacing
Mirrors – Trailer tow, manually telescoping with manual glass and manual 2-way fold (sail mount)
Mirrors – Trailer tow, power-telescoping with power-folding, heated, includes heated convex integrated blind spot mirrors, integrated clearance lamps with turn signal indicators (sail mount); (XLT only, n/a with air conditioning delete)
Wheel ornamentation – Front/rear, Ford bright center cap and lug nut covers (polished aluminum wheels only)

CAB EQUIPMENT – INTERIOR

Air conditioning delete, fresh air heater and defroster only (XL only)
AM/FM stereo/single-CD player with MP3 capability, dash-mounted audio input jack, clock and 2 speakers (Regular Cab), 4 speakers (SuperCab/Crew Cab) (included on XLT)
Back panel trim cover (Regular Cab/Crew Cab only)
Black, leather-wrapped 2-spoke steering wheel with integral cruise control switches, 15.5-in. diameter only (available on XLT only)
Color-coordinated carpet floor covering (available on XLT and with leather-trimmed or 40/20/20 split front seats)
Front, floor-mounted console between seats with dual cupholders and tray, (n/a with 70% front-passenger seat, or 40/20/40 split front seats, or leather-trimmed seats)
Front, floor-mounted full console between seats includes dual cupholders and large storage compartment with lid (available only with leather-trimmed seats and carpet)
Hour meter located in Overhead Pod (Pod replaces overhead console if equipped, front map lights relocated mid-cab on SuperCab/Crew Cab)
Non-self-canceling turn signal switch (tractor use only, n/a on Pro Loader)
Transmission temperature gauge/hour meter located in Overhead Pod
Transmission temperature gauge/hour meter/voltmeter located in Overhead Pod
Transmission temperature gauge located in Overhead Pod (Pod replaces overhead console if equipped, front map lights relocated mid-cab on SuperCab/Crew Cab), Allison Transmission only
Voltmeter located in Overhead Pod (Pod replaces overhead console if equipped, front map lights relocated mid-cab on SuperCab/Crew Cab; replaces overhead console)

FORD WORK SOLUTIONS™⁴

Crew Chief™
In-dash Windows® CE computer with touch screen

Business Preferred Network. Each of the select dealerships in our Business Preferred Network (BPN) is committed to providing quality commercial-oriented products and service, as well as special financing and billing arrangements, to businesses that rely on Ford products. As a BPN customer, your business vehicles receive priority service at your BPN dealership to help get your vehicle back on the road quickly.

Financial Services. Our commercial purchase plans and lines of credit offer attractive rates, negotiable terms and business-friendly options. If you prefer to lease, our CommercialLeaseSM programs offer a wide variety of package options to meet your needs. For additional information, please visit our website at fordcredit.com/comlend/.

Ford Extended Service Plan. For a purchase or lease, the Ford Extended Service Plan (ESP) gives you "Peace-of-Mind" protection designed to cover key vehicle components and protect you from the cost of unexpected repairs. Ask your dealer for a Ford ESP, the only service contract backed exclusively by Ford and honored at all Ford dealerships.

Comparisons based on 2010 competitive models (class is Medium Duty Trucks), publicly available information and Ford certification data at time of release. Some features discussed may be optional. Vehicles throughout this PDF are shown with optional and aftermarket equipment. Features shown may be offered only in combination with other options or subject to additional ordering requirements or limitations. Dimensions and capability ratings

shown may vary due to optional features and/or production variability. Following release of the PDF, certain changes in standard equipment, options and the like, or product delays may have occurred which would not be included in these pages. Your Ford Dealer is the best source for up-to-date information. Ford Division reserves the right to change product specifications at any time without incurring obligations. Body manufacturers are responsible for compliance certification of the completed vehicle. The Ford New Vehicle Limited Warranty and any government certification made by Ford shall cover only the vehicle as manufactured by Ford and shall not extend to any addition, modification or change of or to the vehicle by the Ford Authorized Pool Account.

2011
NEW F-650/F-750 SUPER DUTY®

commtruck.ford.com



TECHNICAL SPECIFICATIONS

FRAMES

MODEL	FRAME ORDER CODE											
	533	534	535	536	537	538	539	53F	53A	53J	53L	412/410
F-650 Pro Loader®	—	—	—	—	●	—	—	—	—	—	—	—
F-650 ¹	○	●	●	○	—	—	—	—	—	—	—	—
F-750	—	—	○	○	—	○	○	○	●	○	○	○
Depth (in.)	9.125	10.125	10.250	10.125	9.125	10.250	10.375	10.125	10.250	10.250	10.375	10.813
Width (in.)	3.062	3.062	3.092	3.580	3.062	3.610	3.705	3.580	3.092	3.610	3.705	3.892
Thickness (in.)	0.312	0.312	0.375	0.312	0.312	0.375	0.438	0.375	0.375	0.375	0.438	0.312
Yield (psi)	80,000	50,000	80,000	120,000	80,000	120,000	120,000	120,000	80,000	120,000	120,000	120,000
Maximum section modulus (cu. in.)	11.47	13.31	15.94	14.84	11.47	17.79	21.05	14.84	15.94	17.79	21.05	29.84
Max. resisting bending moment (in.-lbs.)	917,600	665,500	1,275,200	1,780,800	917,600	2,134,800	2,526,000	1,780,800	1,275,200	2,134,800	2,526,000	3,580,800

SUSPENSIONS

MODEL	FRONT SPRING RATING (LBS.)					REAR MULTI-LEAF SPRINGS RATING (LBS.)						REAR AIR SUSPENSION RATING (LBS.)				
	8,500	10,000	12,000	13,200	14,000	15,500	17,500	18,500	20,000	23,500	31,000	12,000	15,500	18,500	20,000	23,000
F-650 Pro Loader	●	○	—	—	—	—	●	—	—	—	—	○	○	○	—	—
F-650 ¹	●	○	—	—	—	○	—	●	○	—	—	—	—	○	○	—
F-750	—	●	○	○	○	—	—	—	—	●	○	—	—	—	○	○

¹Badged as Pro Loader when equipped with 19.5-in. wheels.

● Standard ○ Optional ● Select availability — Not available

AXLES

MODEL	FRONT AXLE RATING (LBS.)					REAR AXLE RATING (LBS.)						2 SPEED	
	8,500	10,000	12,000	13,200	14,000	SINGLE SPEED						21,000	23,000
F-650 Pro Loader	●	○	—	—	—	●	○	○	—	—	—	—	—
F-650 ¹	●	○	—	—	—	—	—	●	○	—	—	—	—
F-750	—	●	○	○	○	—	—	—	—	●	○	○	○

DIMENSIONS

	REGULAR CAB	SUPERCAB	CREW CAB
A. Overall height	88.3" - 94.7"	88.6" - 94.6"	89.1" - 95.1"
B. Width at front fenders	96.7"	96.7"	96.7"
C. Frame rail spacing	34.0"	34.0"	34.0"
D. Front bumper to back of cab	113.0"	134.0"	148.0"
E. Loadfloor height	33.6" - 40.4"	33.6" - 40.4"	33.6" - 40.4"
F. Front bumper to center of front axle	39.0"	39.0"	39.0"
G. Wheelbase	134.0" - 281.0"	155.0" - 281.0"	170.0" - 266.0"
H. Center of rear axle to end of frame	39.0" - 120.0"	39.0" - 120.0"	39.0" - 87.0"
I. Back of cab to center of front axle	74.0"	95.0"	110.0"
J. Back of cab to center of rear axle	60.0" - 207.0"	60.0" - 186.0"	60.0" - 156.0"

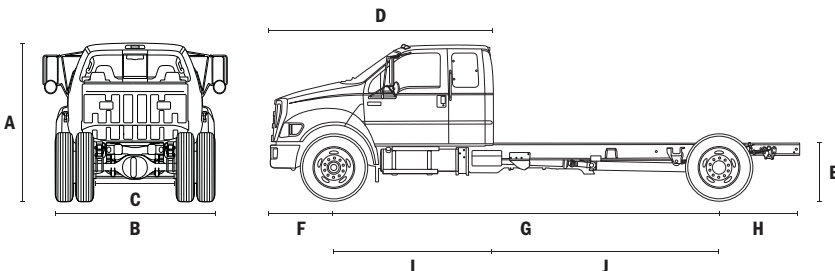

2011
NEW F-650/F-750 SUPER DUTY®

commtruck.ford.com



TECHNICAL SPECIFICATIONS

FUEL TANKS

MODEL	13-IN. TANK DEPTH – SHALLOW (GALS.)								16-IN. TANK DEPTH – DEEP (GALS.)						BETWEEN-THE-RAIL
	35	45	65	35/45	45/45	65/45	65/65	–	–	–	–	–	–	–	
F-650 Pro Loader	35	45	65	35/45	45/45	65/45	65/65	–	–	–	–	–	–	–	
F-650 ¹	35	45	65	35/45	45/45	65/45	65/65	50	65	80	50/50	65/65	80/65	65	
F-750	35	45	65	35/45	45/45	65/45	65/65	50	65	80	50/50	65/65	80/65	65	

¹Badged as Pro Loader when equipped with 19.5-in. wheels.

WEIGHT RATINGS & WHEELBASE/CAB-TO-AXLE RANGES

MODEL	GVWR (LBS.)	CAB	WHEELBASE/CAB-TO-AXLE RANGE (IN.)	OPTIONS
F-650 Pro Loader	20,160 – 26,000	Regular Cab	134/60 – 242/168	6
		SuperCab	155/60 – 239/144	4
		Crew Cab	170/60 – 254/144	4
F-650 ¹	20,940 – 29,000	Regular Cab	146/72 – 281/207	14
		SuperCab	167/72 – 281/186	13
		Crew Cab	182/72 – 278/168	12
F-750	25,999 – 37,000	Regular Cab	146/72 – 281/207	15
		SuperCab	167/72 – 281/186	13
		Crew Cab	182/72 – 266/156	11

WHEEL AVAILABILITY

WHEEL	F-650 PRO LOADER	F-650 ¹	F-750
19.5 x 6.75 8-lug white powder-coated steel	●	○	–
19.5 x 7.5 8-lug polished aluminum ²	○	○	–
19.5 x 7.5 10-lug white powder-coated steel	○	○	–
19.5 x 7.5 10-lug polished aluminum ²	○	○	–
22.5 x 7.5 10-lug white powder-coated steel	–	●	●
22.5 x 8.25 10-lug white powder-coated steel	–	○	○
22.5 x 8.25 10-lug polished aluminum	–	○	○
Wheel ornamentation – Ford bright center cap and lug nut covers	○	○	○

²Outer wheel only – inner wheel is steel.



Polished Aluminum with Optional Wheel Ornamentation (front)



White Powder-Coated Steel (front)

TIRE AVAILABILITY

F-650 PRO LOADER	F-650 ¹	F-750	TIRE SIZE ³	LOAD RANGE (PR)	STEEL	ALUMINUM
○	○	–	225/70R19.5F	12	○	○
○	○	–	225/70R19.5G	14	○	○
○	○	–	245/70R19.5F	12	○	○
●	○	–	245/70R19.5G	14	○	○
○	○	–	245/70R19.5H	16	○	○
○	○	–	265/70R19.5G	14	○	○
–	○	○	9R22.5F	12	○	–
–	○	○	10R22.5F	12	○	–
–	○	○	10R22.5G	14	○	–
–	○	○	11R22.5G	14	○	○
–	●	●	11R22.5H	16	○	○
–	○	○	235/80R22.5G	14	○	–
–	○	○	255/70R22.5H	16	○	○
–	○	○	255/80R22.5G	14	○	○
–	○	○	275/70R22.5H	16	○	○
–	○	○	275/70R22.5J	18	○	○
–	○	○	275/80R22.5G	14	○	○
–	○	○	295/75R22.5G	14	○	○
–	○	○	295/80R22.5H	16	○	○

³Due to industry-wide tire availability shortages, tire substitutions may be required at time of vehicle production.

©2010 Ford Motor Company 11F67WEBPDF

2011
NEW F-650/F-750 SUPER DUTY®

commtruck.ford.com

